

TOMMY TUNNEL™

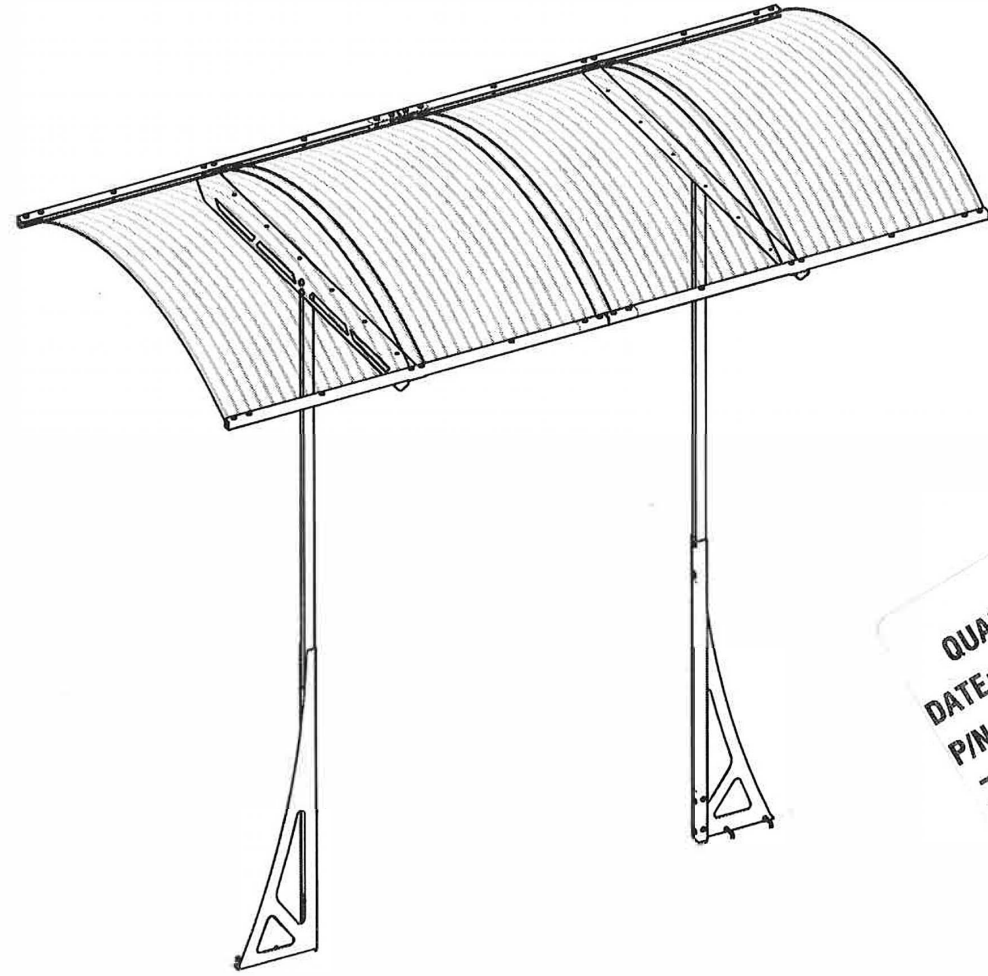

QUALITY ASSURANCE
DATE: 23
P/N : 51 BATCH NO.: 7133569
Z : 9.380 X : 0.000
Y : 9.380

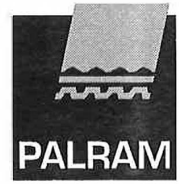

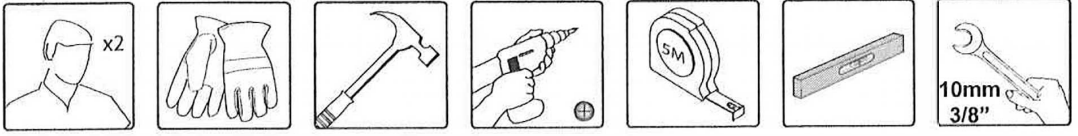

1

PARTS REQUEST

In the case of missing or damaged parts, do not return product to store.

Go to the link below or scan the QR code for help, it will direct you to a form that will help us assist you as soon as possible.



SCAN ME

Contact us on our website:
bit.ly/3js7yZi

2

ASSEMBLY ASSISTANCE

If you need any technical assistance in assembling your product, go to the link below or scan the QR code for help. It will direct you to a form that will help us assist you as soon as possible.



SCAN ME

Contact us on our website:
bit.ly/3kqqFEc



SCAN ME

WE ARE HERE TO HELP

For general questions: bit.ly/3kY07dP

USA

877-627-8476

hobbyservice@poly-tex.com

CANADA

905-5646007

sales@footprintproducts.com

UNITED KINGDOM · IRELAND

01302-380775

customer.serviceUK@palram.com

GERMANY

0180-522-8778

customer.serviceDE@palram.com

FRANCE · BELGIUM

+33-169-791-094

customer.serviceFR@palram.com

ISRAEL

04-848-6816

info.il@palram.co.il

ITALY · NETHERLANDS · PORTUGAL · SPAIN

+33-169-791-094

customer.serviceFR@palram.com

AUSTRIA · LUXEMBURG · LIECHTENSTEIN

+49-180-522-8778

customer.serviceDE@palram.com

AUSTRALIA

03-9219-4444

salesvic@palram.com

NORWAY · SWEDEN · ARGENTINA · GREECE · GREENLAND · ICELAND · ESTONIA · JAPAN · LATVIA · LITHUANIA
MAURITIUS · MEXICO · ROMANIA · RUSSIA · TURKEY · UZBEKISTAN · UKRAINE · SWAZILAND · KOREA

+972-4-848-6816

customer.service@palram.com



CUSTOMER SUPPORT



SCAN ME

WE ARE HERE TO HELP

For general questions: bit.ly/3kY07dP

AUSTRALIA - GREENHOUSES

03-9544-6-999

info@mazedistribution.com.au

HUNGARY · SLOVAKIA

+420-493-523-523

servis@garland.cz

NEW ZEALAND

0800 800 880

customer.service@palram.com

DENMARK

07-575 42 70

post@nshnordic.com

SOUTH AFRICA

011-397-7771

receptionza@palram.com

CROATIA · SLOVENIA

0599-37-057

info@ms-viscom.com

CZECH REPUBLIC

0493-523-523

servis@garland.cz

FINLAND

Neuvonta: 09-6866720
Tuki / Varaosat: 050-3715350

www.horizontenterprises.fi
tuki@horizontenterprises.fi

POLAND

Infolinia: 801-011-929
22-349-93-36

kontakt@ogrodosfera.pl

CYPRUS

0224-971-13

alpaco@alpacodomica.com
www.alpacodomica.com

SWITZERLAND

062-287-33-77

info@ritter.ch

IMPORTANT

Please read these instructions carefully before you start to assemble this greenhouse.
Please carry out the steps in the order set out in these instructions.
Keep these instructions in a safe place for future reference.

Before you start

- It is highly recommended to be assisted by a second person in some steps.
- Sort the parts and check against the contents parts list.
- The product must be positioned and fixed on a level surface.
- Please be safe during assembly.

You will need

To assembly your Tommy Tunnel

(these items not supplied)

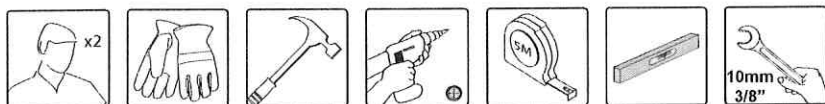

Safety

- This product should be fixed to the ground as shown in these instructions to ensure its stability and wind resistance. Make sure that screws and anchors suit the ground.
- Some parts have metal edges. Please be careful when handling components. Always wear gloves, eye protection, and long sleeves when assembling or performing any maintenance on your product.
- Do not attempt assembly on days with strong winds or low temperatures. If using a stepladder or power tools ensure that you follow the manufacturer's safety advice.
- Do not stand on the roof
- To prevent injuries, do not allow children to play under the product.

Care and Maintenance

- ① When your product needs to be cleaned, use a mild detergent solution and rinse with cold clean water. DO NOT use acetone, abrasive cleaners, or other special detergents to clean the panels.
- ② This product is flexible, you can adjust the height of the product depending on the growth of the crops/plants.
- ③ Periodically check the product to assure that it remains stable.
- ④ Keep roof clean of snow.
- ⑤ In order to extend and create larger shading area, an extension option is available according to **Step 14**.
- ⑥ It is recommended to moisturize the soil in order to facilitate spikes inserting process.

During Assembly

i During assembly you will encounter the information icon, please refer to the relevant assembly step for additional comments and assistance.

Due to product variability assembled size may be slightly different than listed dimensions.

Step 2: Please ensure the panels are overlapping each other by 4.5 cm.

Step 4: Please ensure the panels are overlapping each other by 2 cm.

Steps 7+9: Use a small hammer to insert the spikes. In order to avoid bending is recommended to use a wooden divider.

Step 13: Please push and bend the sheets using another person in order to fix the panels in a domed shape.

Step 15: It is possible to tie a threads into item # 70 in order to create a trellising.

*Company does not supplied threads or wires

Tighten all screws when completing assembly.

WICHTIG

Bitte lesen Sie die vorliegende Anleitung sorgfältig durch, bevor Sie mit dem Zusammenbau des Carport beginnen.

Bitte folgen Sie den Schritten in der Reihenfolge, in der sie in dieser Anleitung aufgeführt sind. Bewahren Sie diese Anleitung für ein späteres Nachlesen sorgfältig auf.

Bevor Sie anfangen

- Es empfiehlt sich sehr, bei einigen Stufen von einer zweiten Person unterstützt zu werden.
- Sortieren Sie die Teile und überprüfen Sie ihre Vollständigkeit mit der Inhaltsliste.
- Das Produkt muss auf einer ebenen Grundlage positioniert und befestigt werden.
- Achten Sie beim Aufbau bitte auf Sicherheit.

Sie benötigen**Für den Aufbau Ihres Tommy Tunnels**

(diese Gegenstände sind nicht enthalten)

**Sicherheit**

- Um Stabilität und Widerstandskraft gegen den Wind zu gewährleisten, sollte dieses Produkt auf dem Boden gemäß den Abbildungen in der Anleitung befestigt werden.
- Einige Teile haben Metallkanten. Bitte gehen Sie beim Anfassen der Teile vorsichtig vor. Tragen Sie beim Aufbau oder bei Arbeiten an Ihrer Hütte stets Handschuhe, Augenschutz und lange Ärmel.
- Versuchen Sie es nicht, Ihr Produkt an sehr windigen und kalten Tagen aufzubauen. Im Falle, Sie benutzen eine Stufenleiter oder elektronische Geräte, befolgen Sie bitte die Sicherheitshinweise des Herstellers.
- Stellen Sie sich nicht auf das Dach.
- Um Unfälle zu vermeiden sollten Kinder davon abgehalten werden, unter dem Produkt zu spielen.

Pflege und Wartung

- 1 Um Ihr Produkt zu reinigen, benutzen Sie ein mildes Reinigungsmittel und waschen es mit kaltem, sauberem Wasser ab. Benutzen Sie für die Reinigung der Platten KEIN Azeton, Scheuermittel oder andere spezielle Reinigungsmittel.
- 2 Dieses Produkt ist beweglich: die Höhe des Produkts kann dem Wachstum der Pflanzen angepasst werden.
- 3 Überprüfen Sie gelegentlich das Produkt, um seine Stabilität sicherzustellen.
- 4 Halten Sie das Dach schneefrei.
- 5 Im Fall eines Mehrbedarfs an Schatten ist eine Erweiterung optional verfügbar wie in Schritt 14 beschrieben.
- 6 Eine Befeuchtung des Bodens erleichtert das Einsetzen der Spieße.

Während des Aufbaus

i Beim Aufbau wird Ihnen das Informationssymbol begegnen. Für zusätzliche Kommentare und Unterstützung beziehen Sie sich bitte auf die passende Aufbaustufe.

Aufgrund der Unterschiedlichkeit der Produkte kann die Endgröße eventuell leichte Unterschiede zu den aufgelisteten Ausmaßen aufweisen.

Schritt 2: Stellen Sie sicher, dass die Platten 4,5cm überlappen.

Schritt 4: Stellen Sie sich, dass die Platten 2cm überlappen.

Schritt 7 + 9: Nutzen Sie einen kleinen Hammer um die Spieße zu verankern. Um ein Verbingen zu vermeiden, nehmen Sie sich ein Stück Holz zur Hilfe.



Schritt 13: Nehmen Sie eine zweite Person zur Hilfe und drücken/biegen Sie die Platten um diese in eine gewölbte Position zu fixieren.



Schritt 15: Es ist möglich eine Gewinde in Teil #70 zu drehen um eine Rankhilfe zu befestigen.



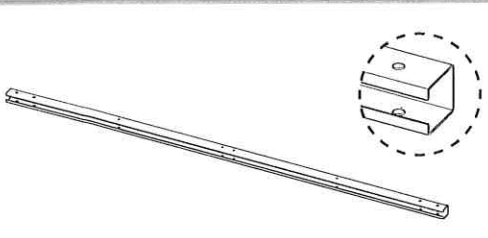
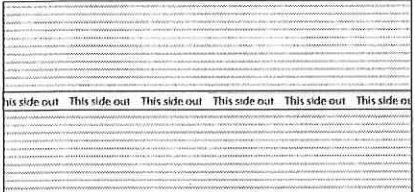
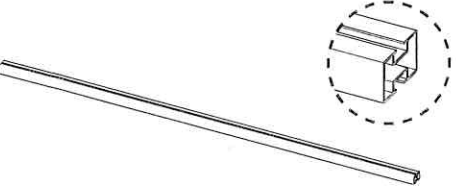
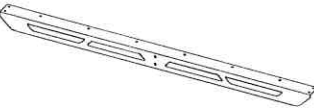
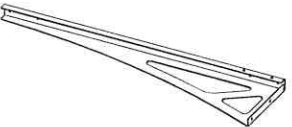



* Das Unternehmen liefert weder Fäden noch Drähte.

Alle Schrauben befestigen nach dem Abschluss der Montage

Contents



Item		Qty.
7588		4
7350		4
7592		2
7587		2
7591		2
7590		2

Item		Qty.
7347		4
7589		2

Item		Qty.
411		16 (+2)
466		12 (+1)
429		16 (+2)
4008		16 (+2)
447		8 (+1)
4044		4
70		4

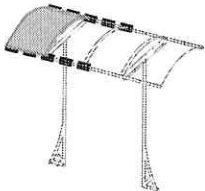
1

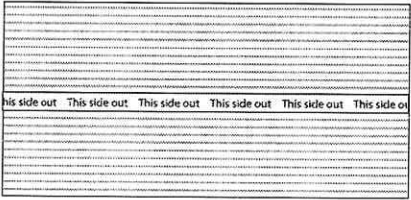

7350  1 4008  2 7588  2

a

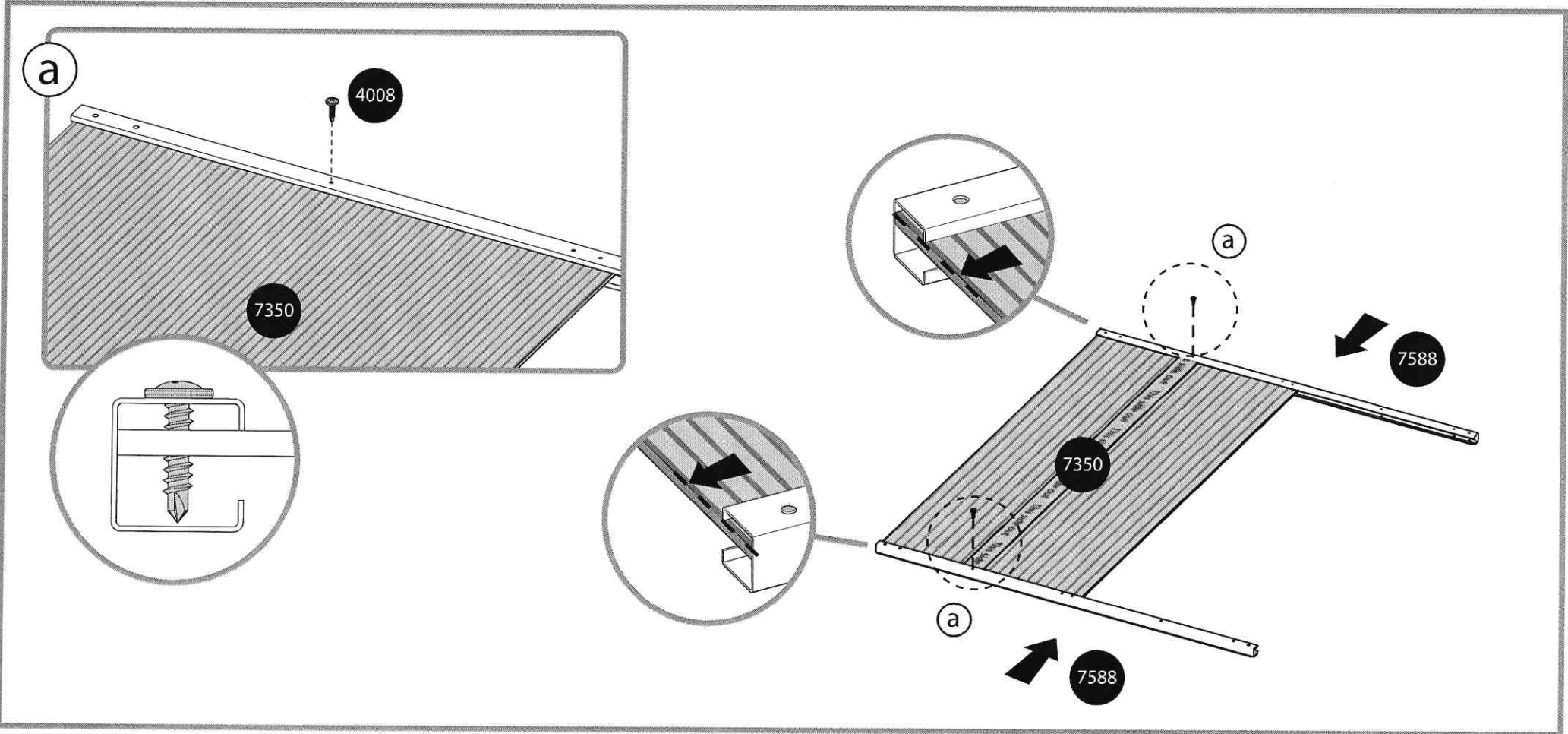

7350

4008

7588

7588

7588

a

a

a

2 **i**



7350

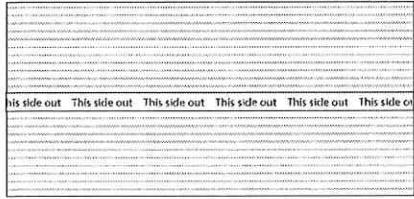

1

4008



2

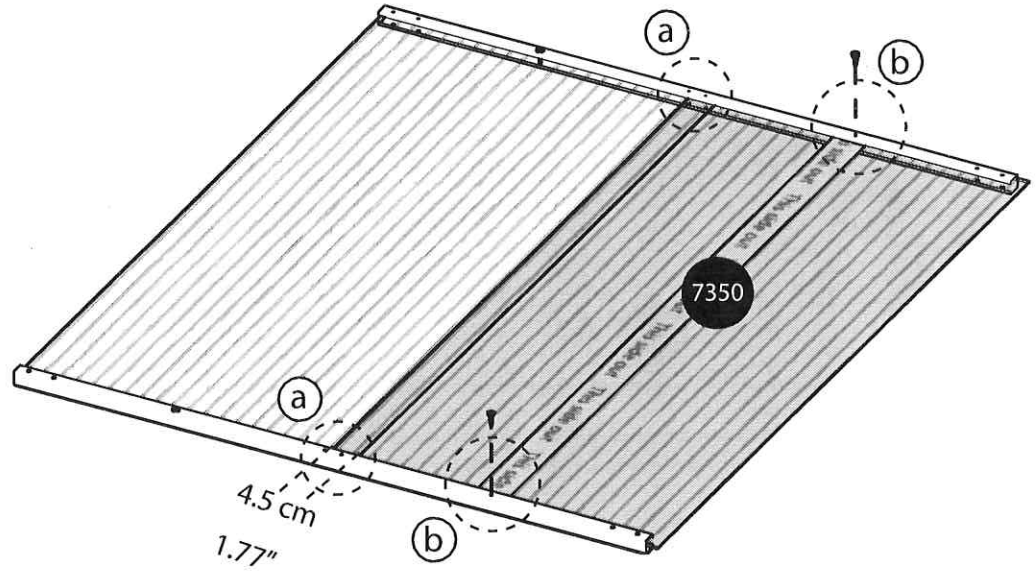
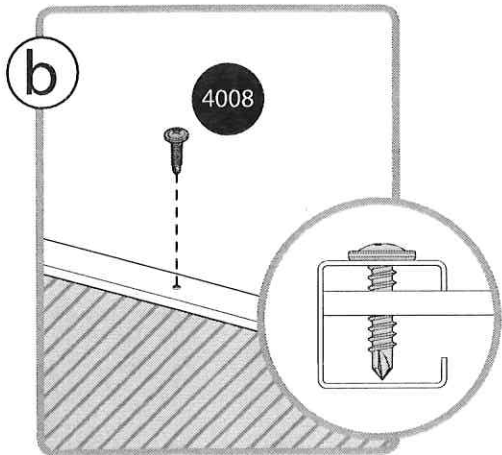
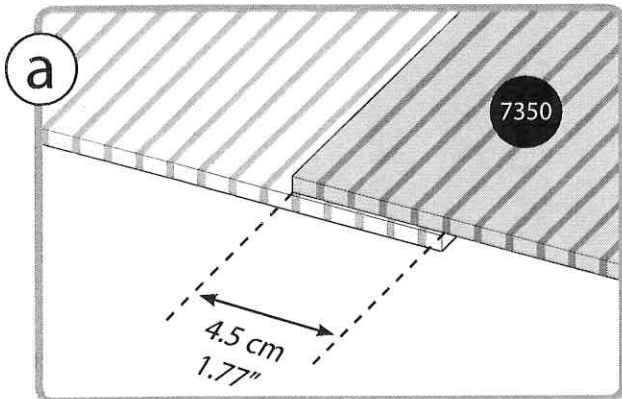

3

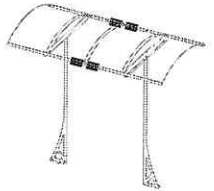

7589

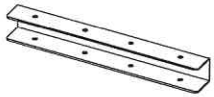

..... 2

429



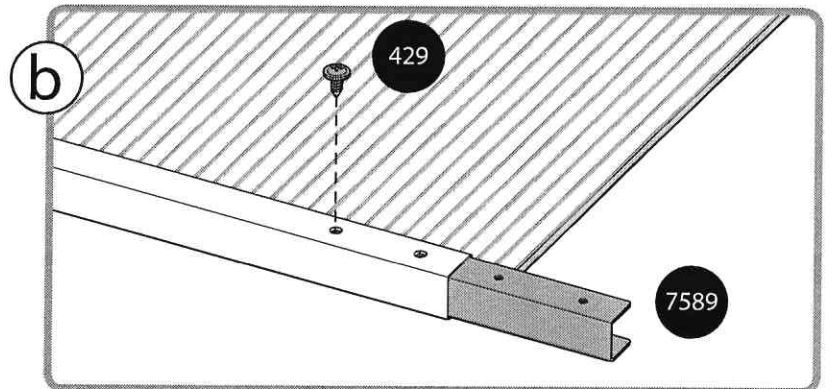
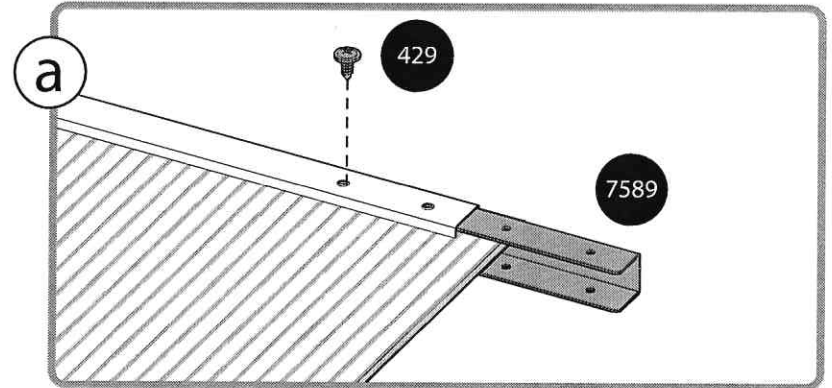
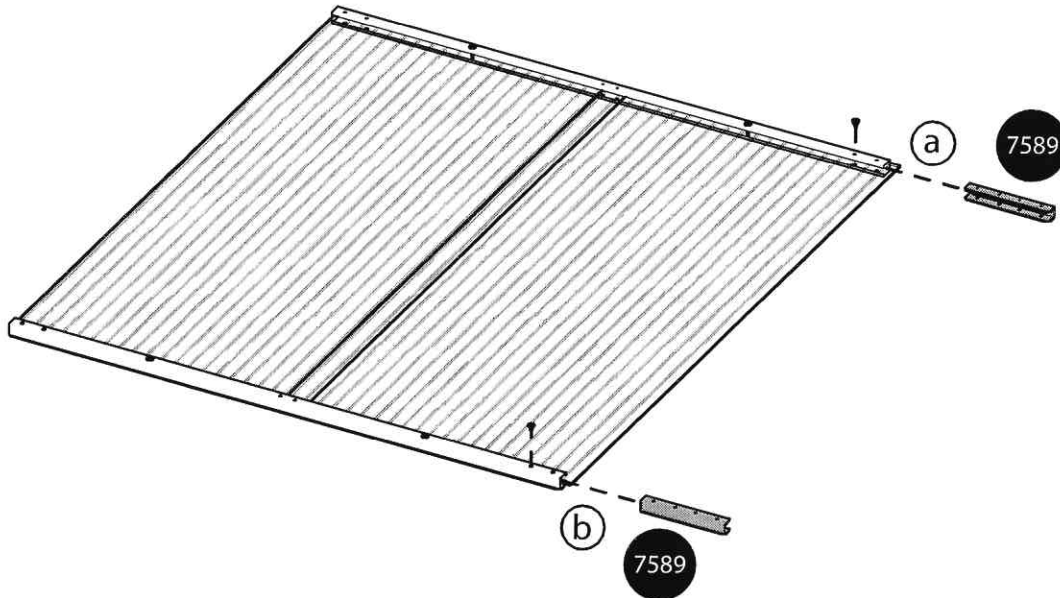

..... 2



4 **i**

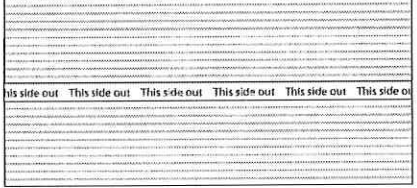

- 7588  2
- 7350  1
- 429  6
- 4008  2

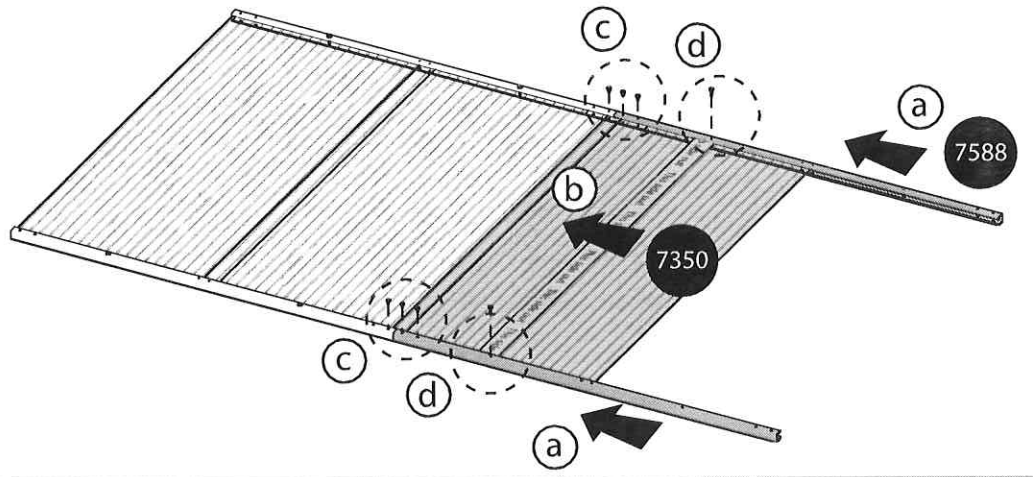
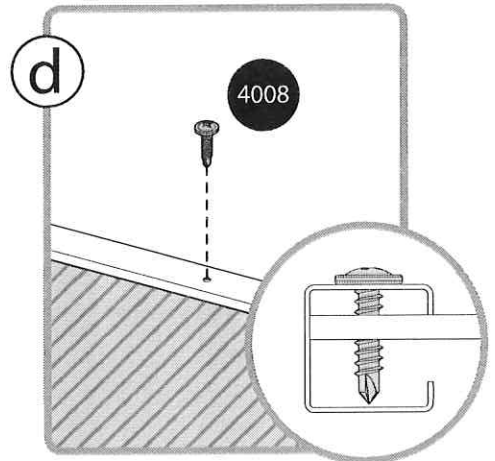
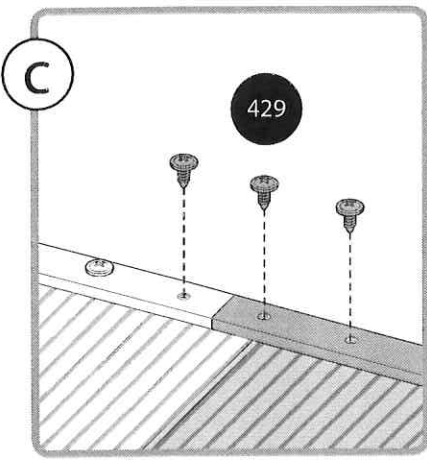
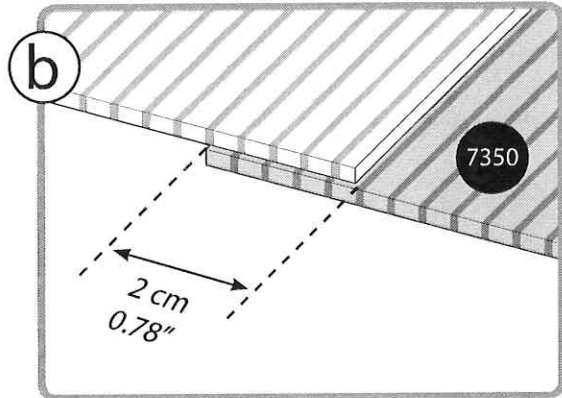
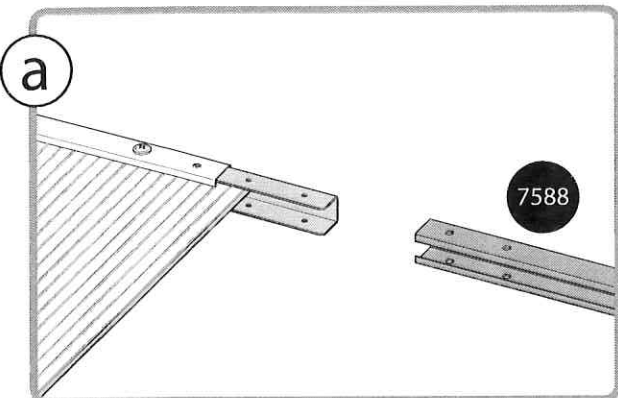

5

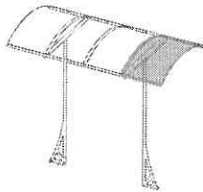

7350

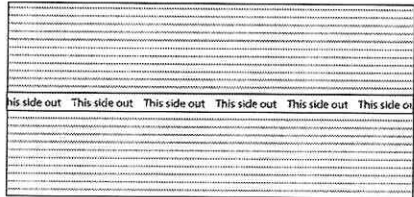

..... 1

4008

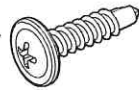

..... 2

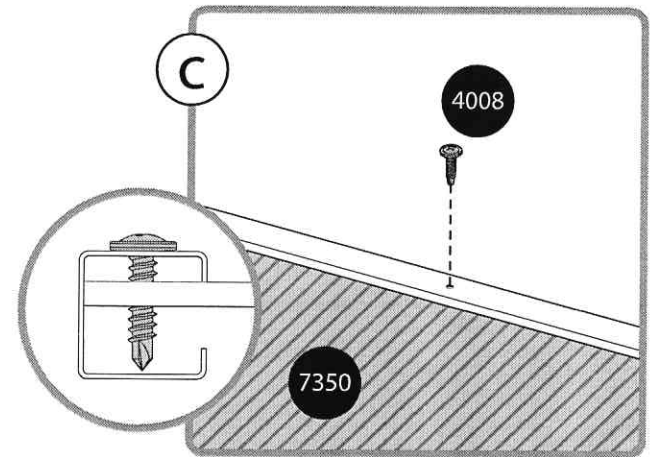
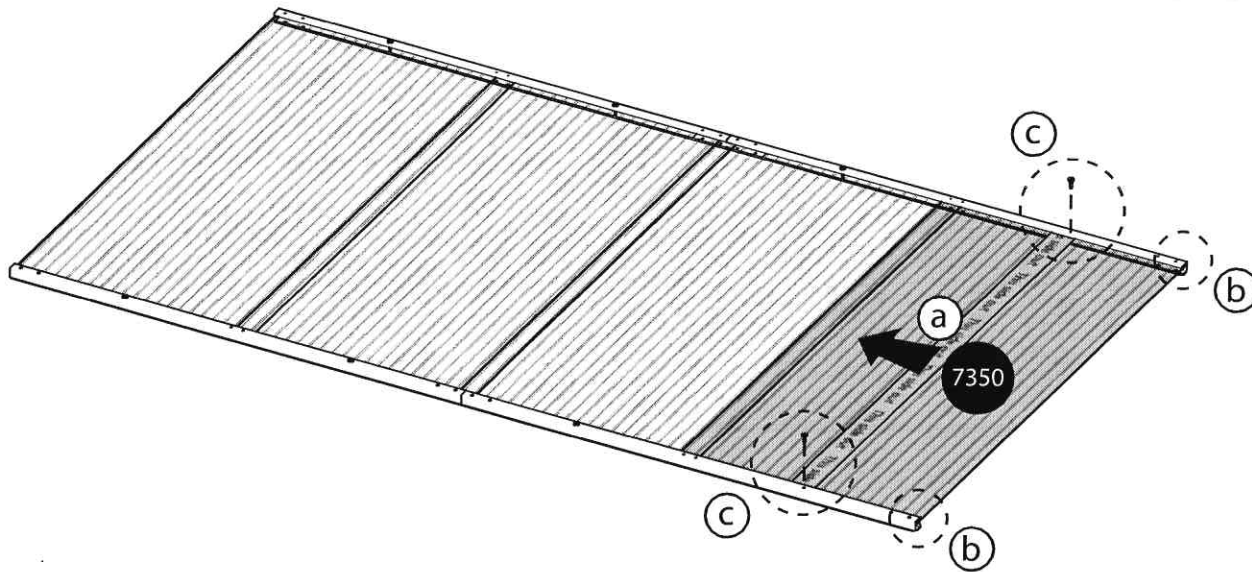
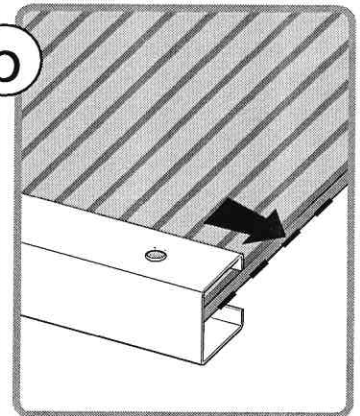
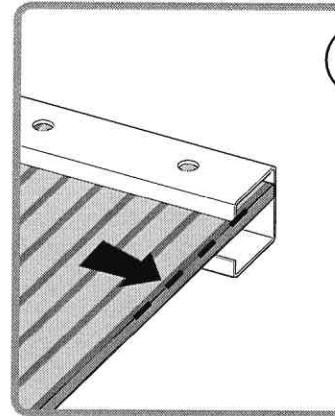
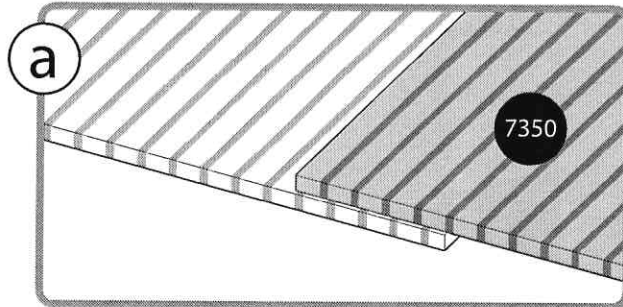

6

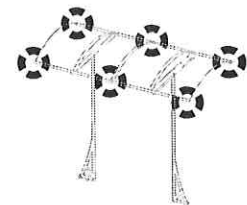

4008 8



429 8

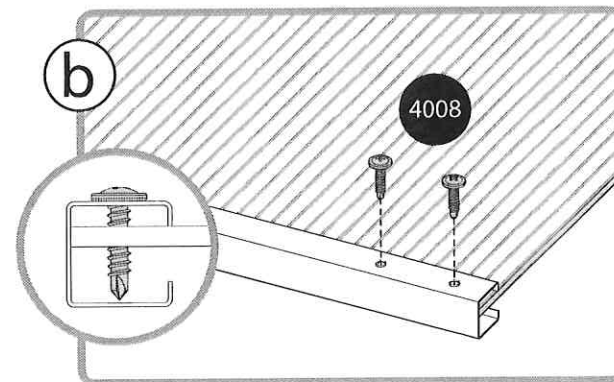
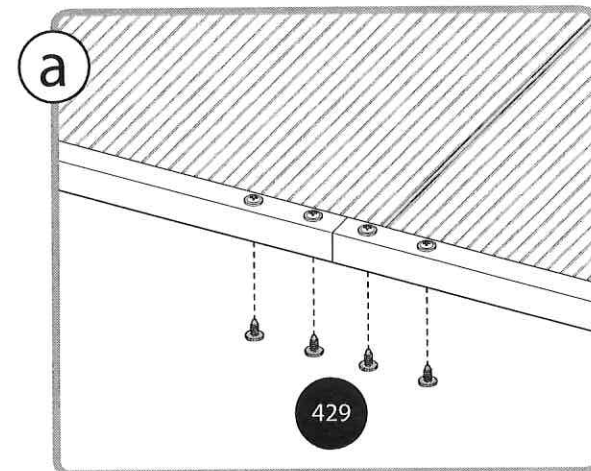
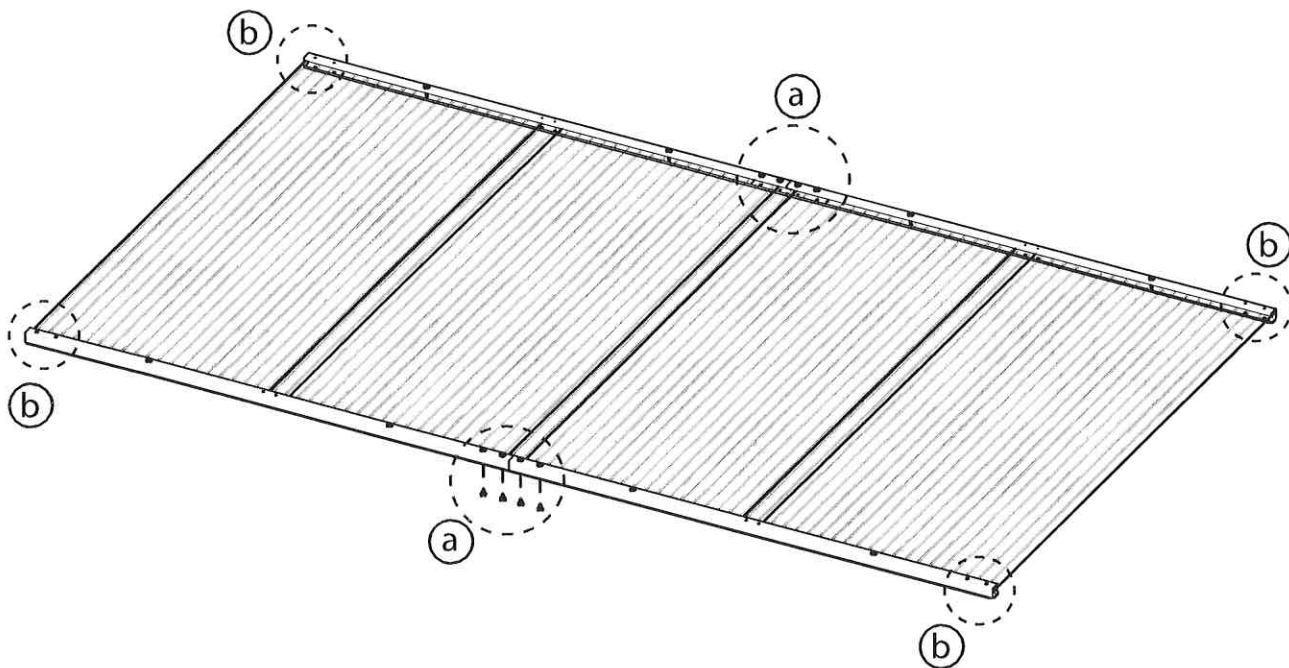

7 **i**

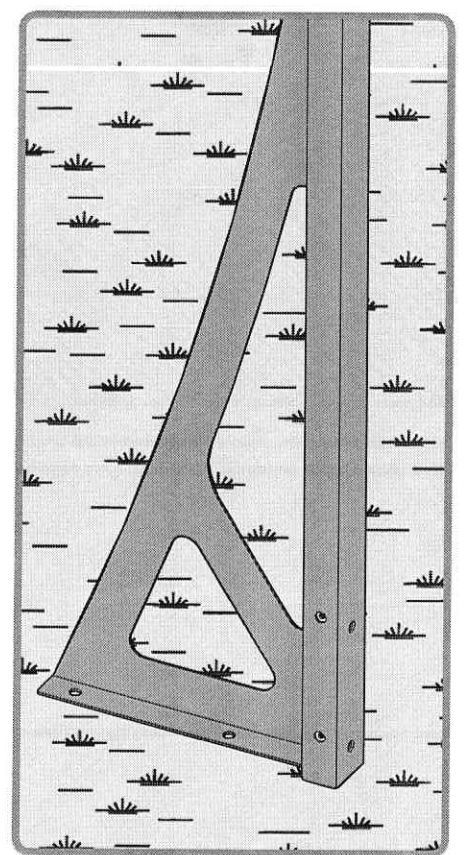
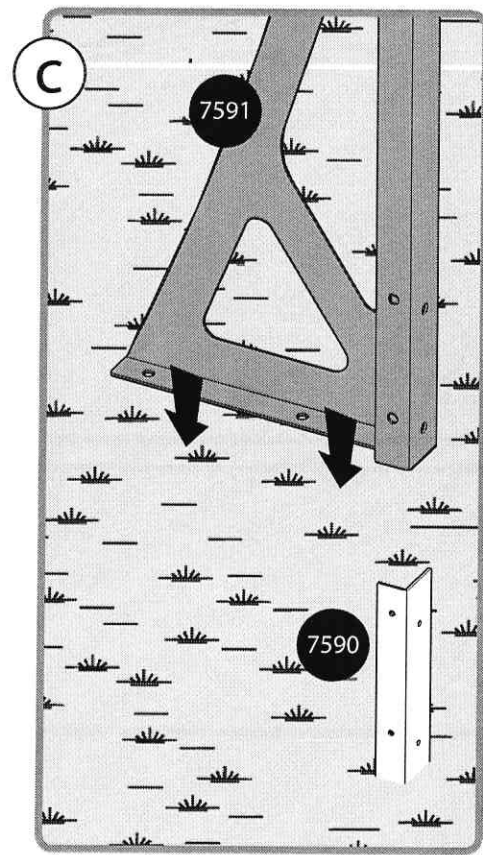
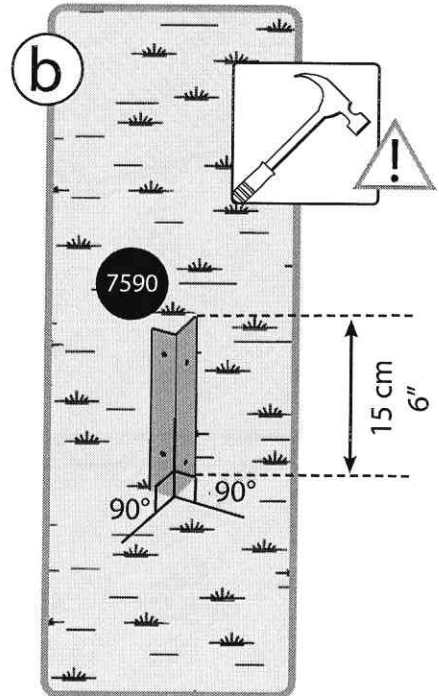
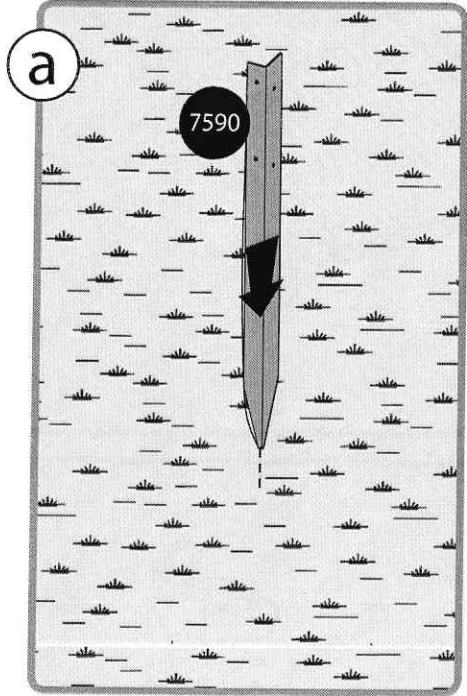
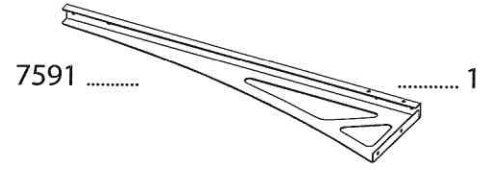
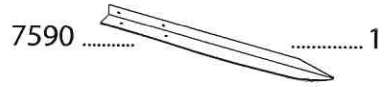
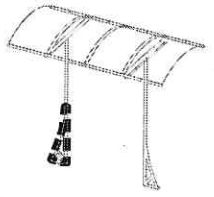



411  4

466  4

7347  2

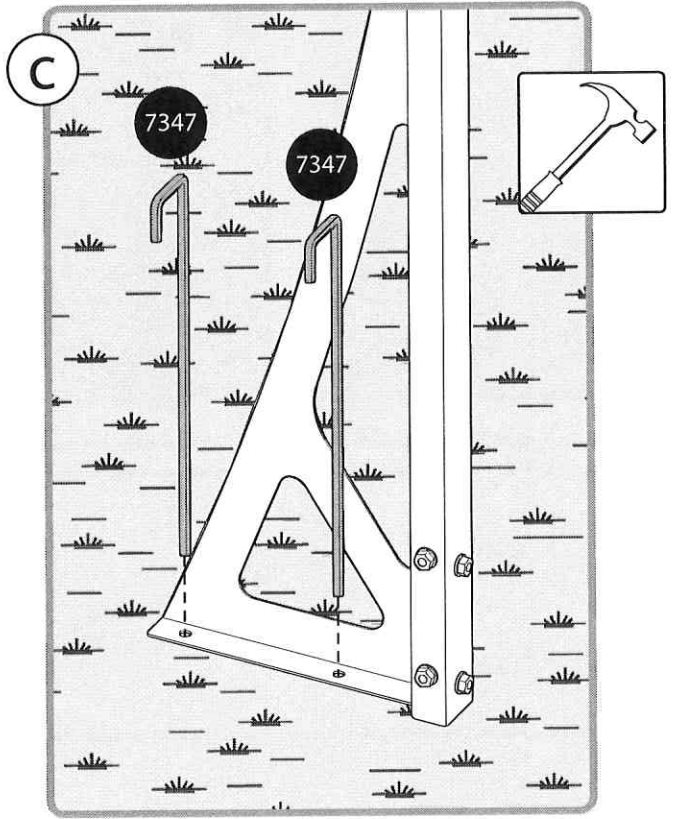
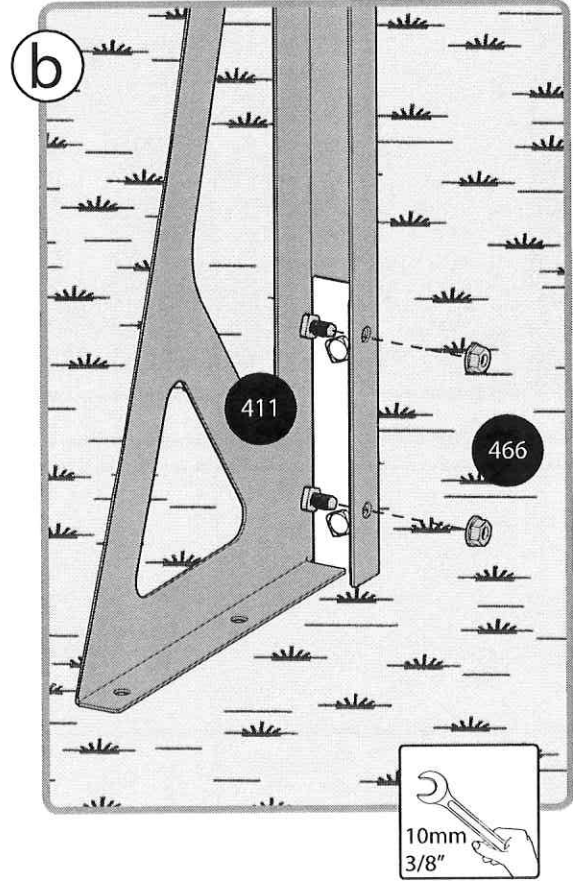
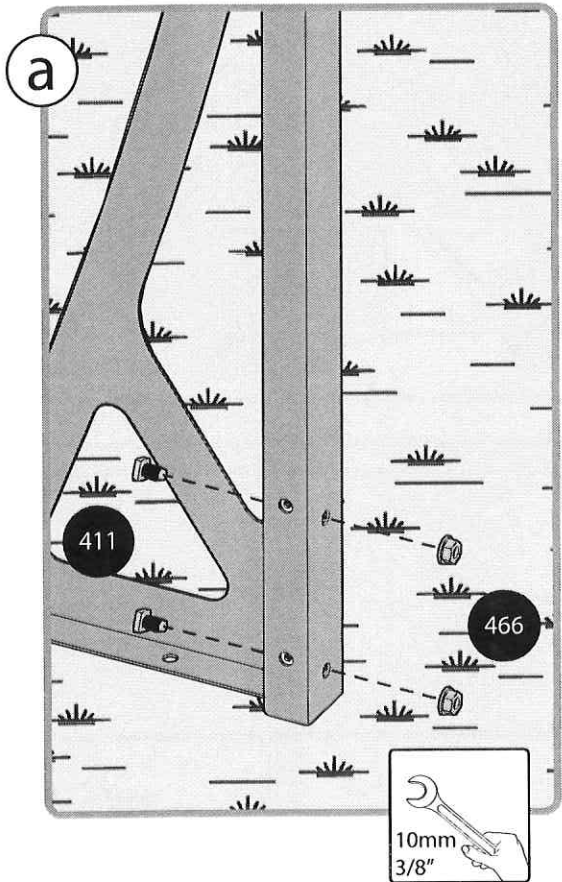

9 **i**

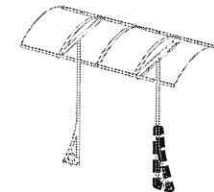

7590 1	7591 1	7347 2	411 4
									466 4

a

b

c

10

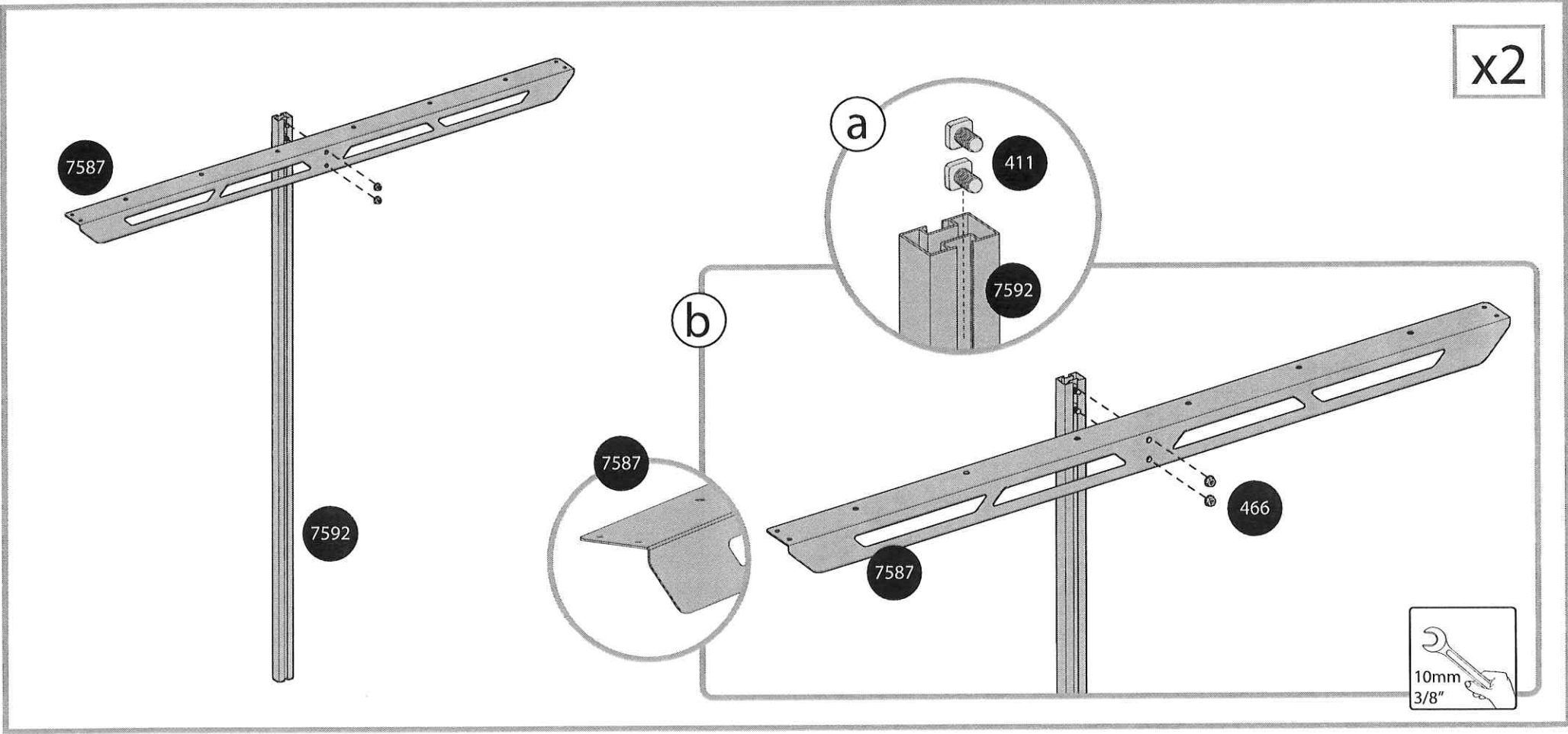
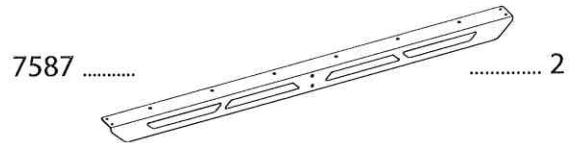
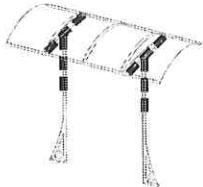



4044  4

411  4

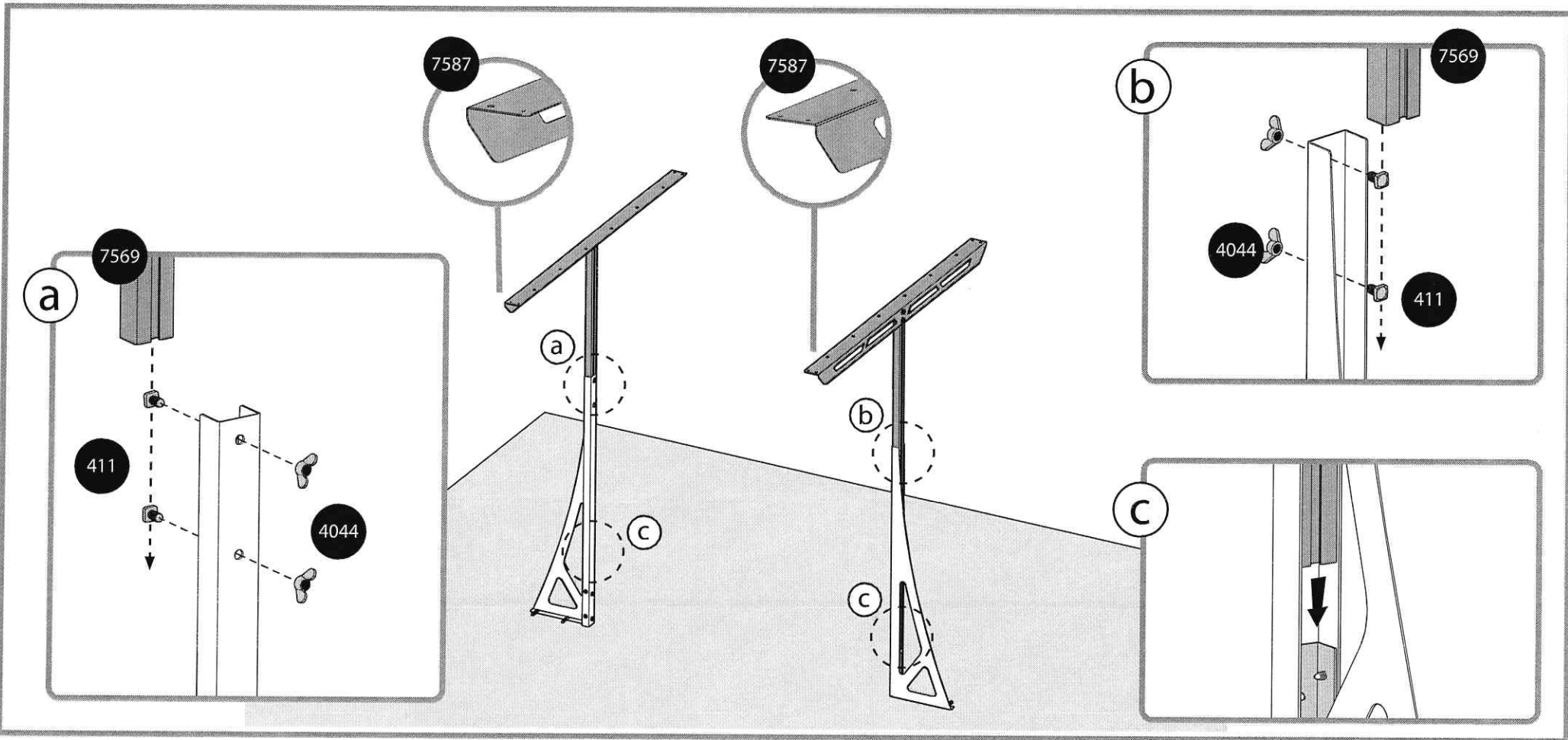



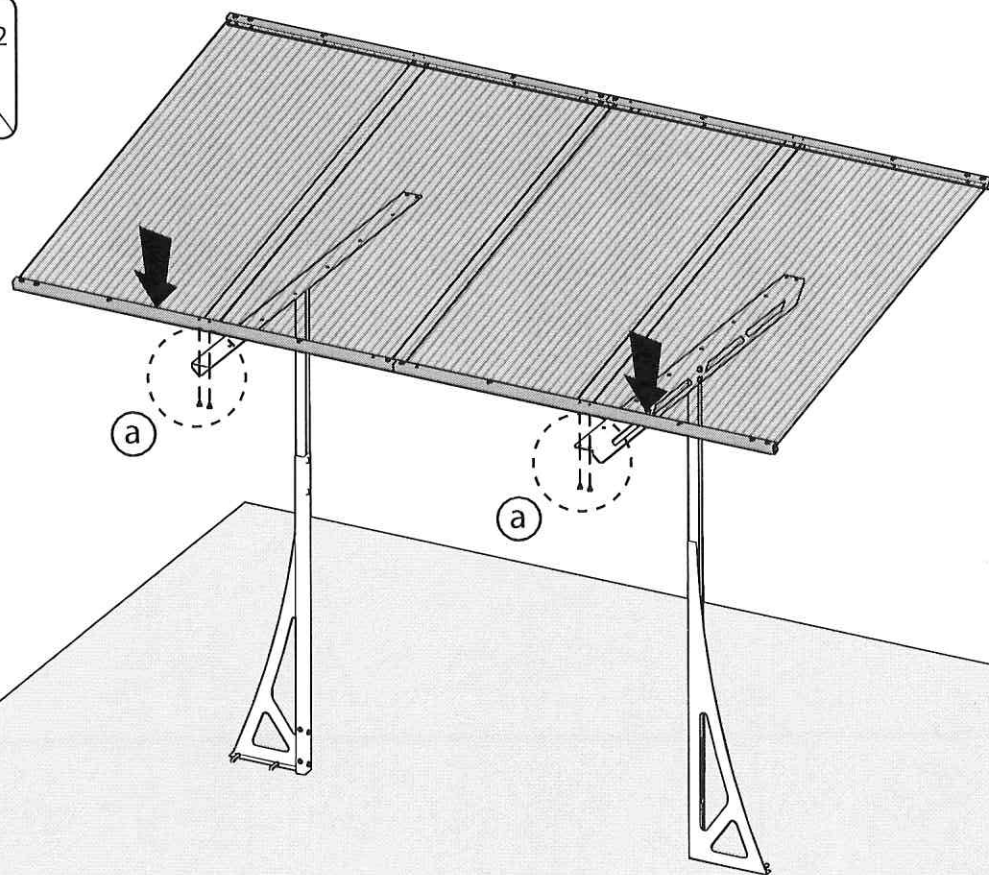
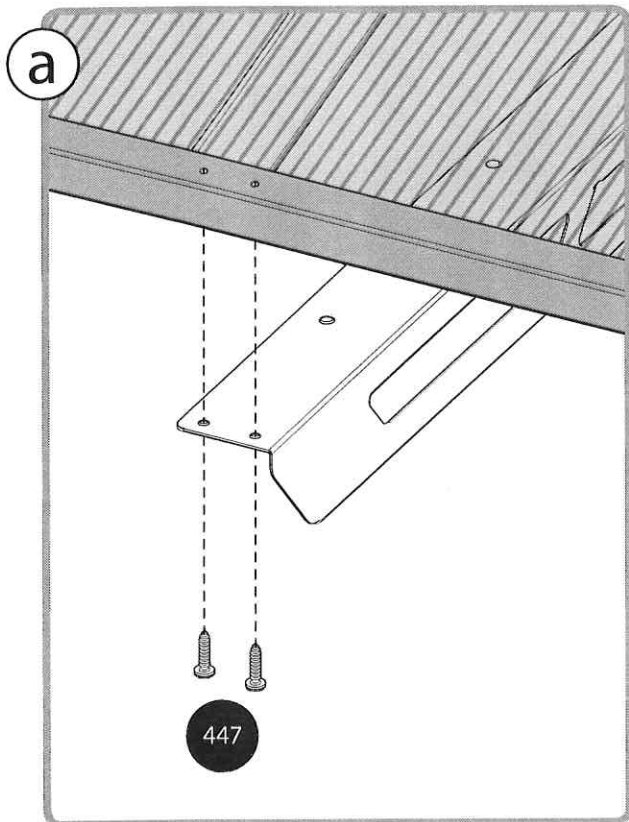

447 4

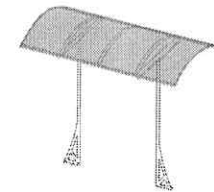

13 **i**



447  4

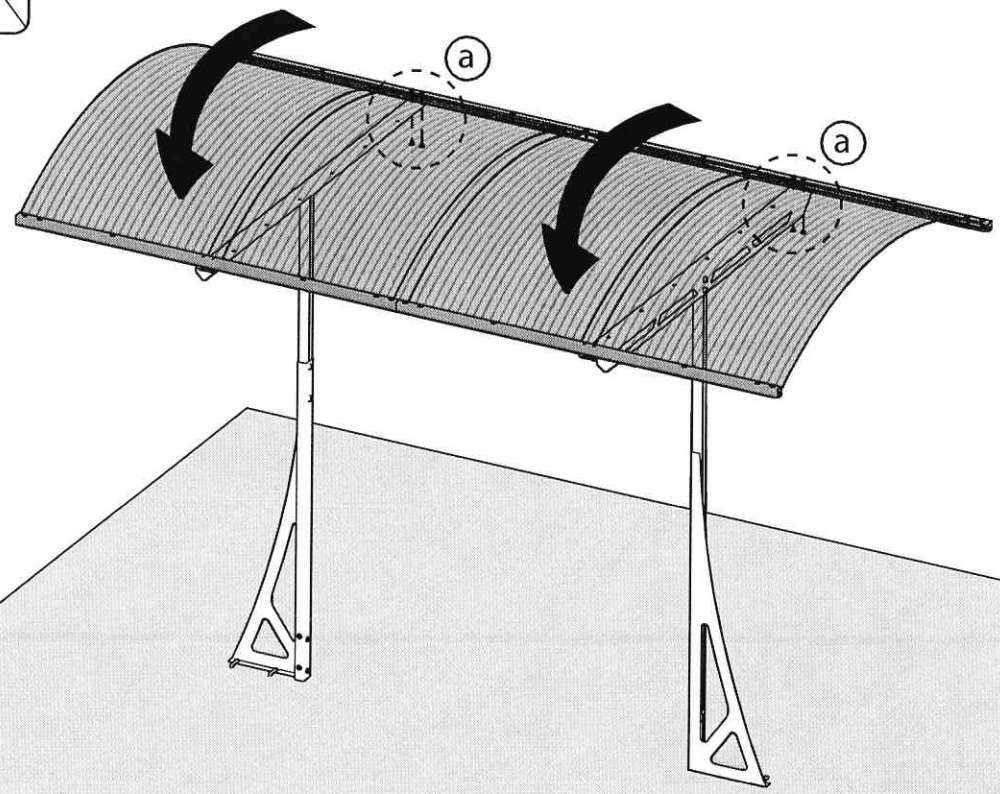
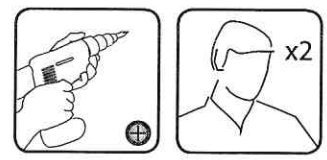
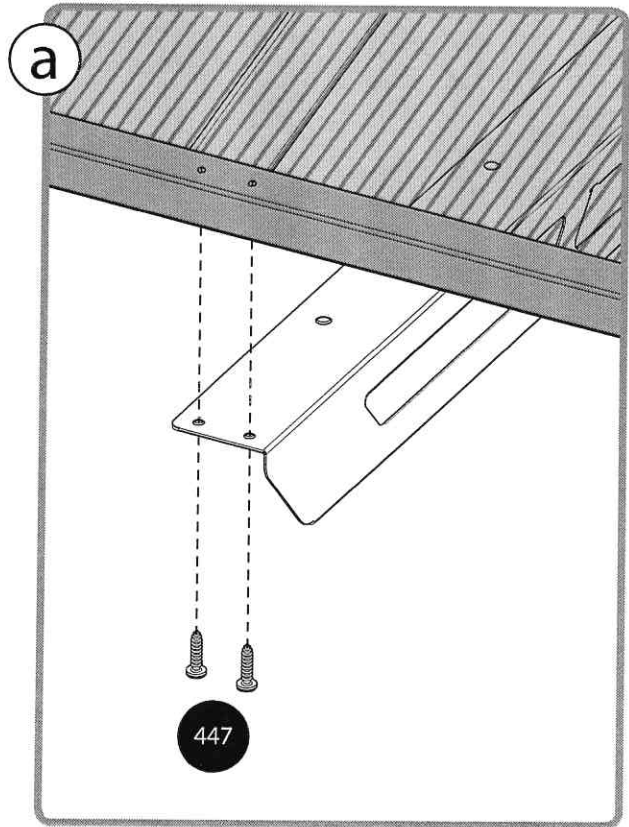

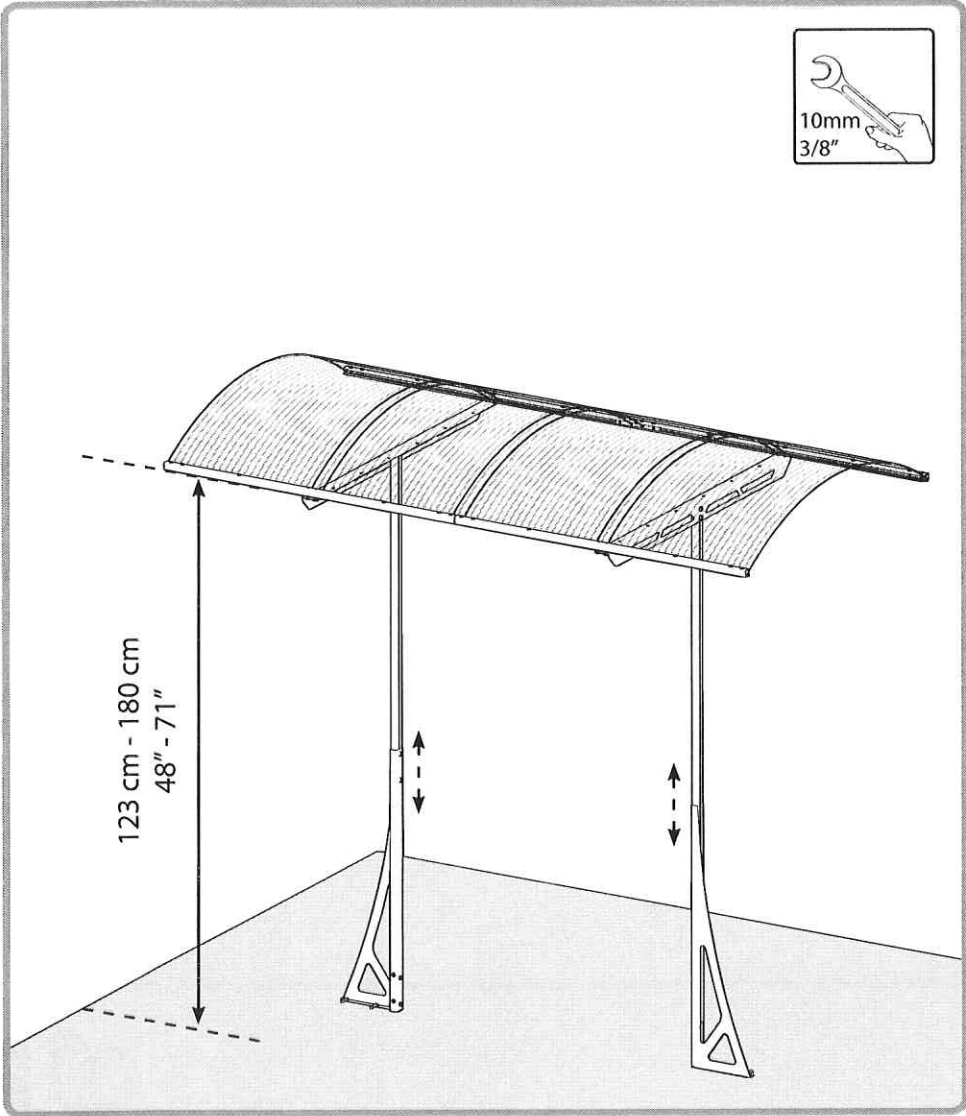
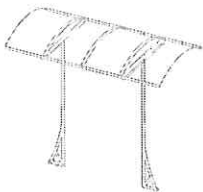

Optional:

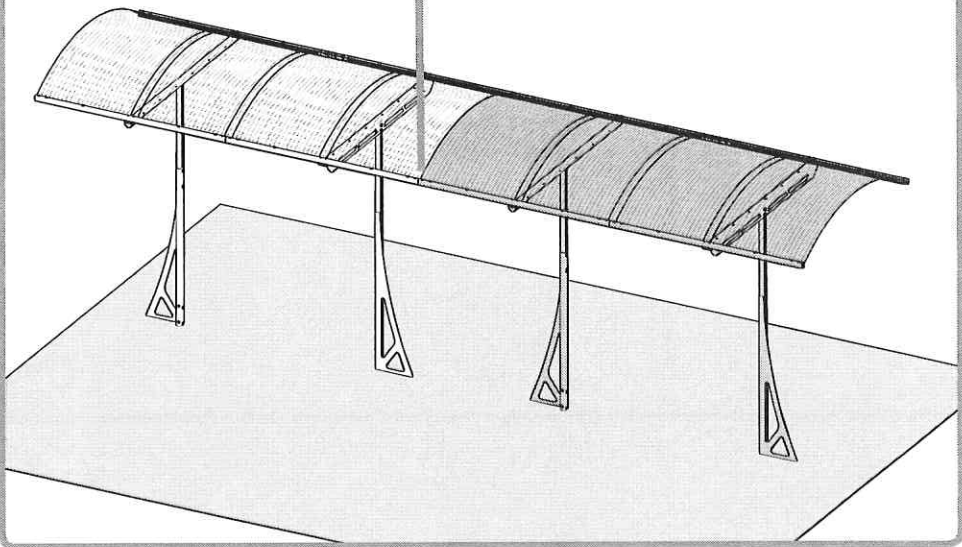
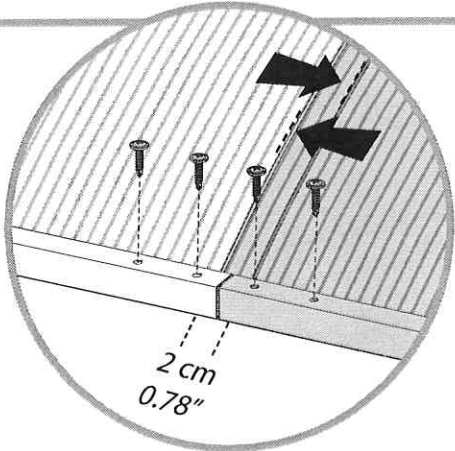

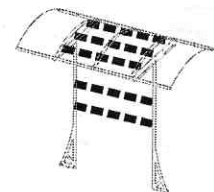

70  4

a

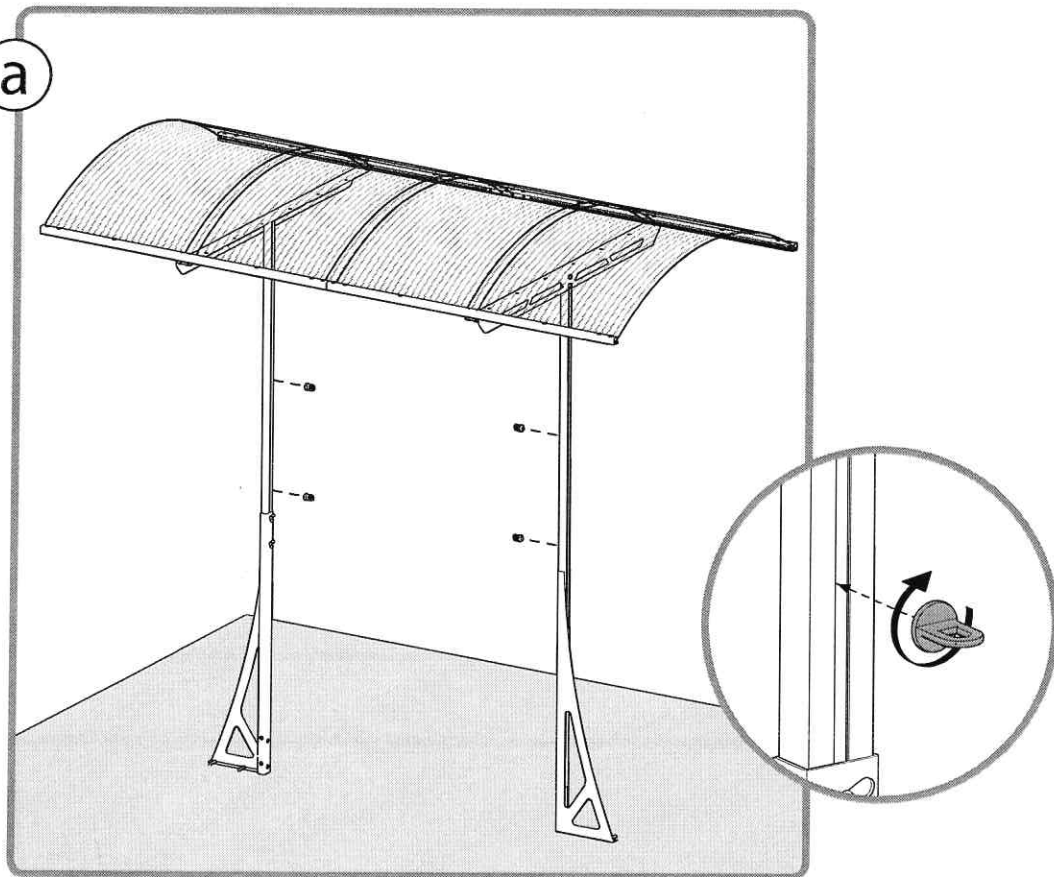

Optional:

