



OUTDOOR STORAGE

60005

Copy



ID:

REGISTER YOUR PRODUCT ONLINE AT WWW.LIFETIME.COM

At Lifetime, we are committed to providing innovative and quality products. While registering, you will have the opportunity to give us your feedback. Your input is valuable to us.

- You can also opt in to receive new product notifications or promotions.
- In the unlikely event of a product recall or safety modification, your registration provides the information we need to notify you directly.
- Registration is fast, easy, and completely voluntary.

LIFETIME'S PROMISE TO YOU:

Maintaining your privacy is our long-standing policy at Lifetime. And you can rest assured that Lifetime will not sell or provide your personal data to other third parties, or allow them to use your personal data for their own purposes.

We invite you to read our privacy policy at www.lifetime.com

REGISTER today!

REGISTRE SU PRODUCTO EN LÍNEA EN WWW.LIFETIME.COM

À Lifetime®, estamos comprometidos a proporcionar productos de calidad e innovadores. Al registrar, tendrá la oportunidad de darnos su opinión. Su opinión es muy valiosa para nosotros.

- Se puede optar inclusión también para recibir notificaciones de nuevos productos o promociones.
- En el caso poco probable de una retirada de un producto o modificación de seguridad, su registro nos provee la información necesario de notificarle directamente.
- El registro es rápido, fácil, y completamente voluntario.

LA PROMESA DE LIFETIME® A USTED:

Mantener su privacidad, es nuestro viejo acuerdo político a Lifetime®. Y puede tener la seguridad de que Lifetime® no venderá ni proveerá sus datos personales a otros terceros, ni les permitirá usar sus datos personales para sus propias intenciones.

Le invitamos a leer nuestra política de privacidad en www.lifetime.com

¡REGÍSTRELO hoy!

ENREGISTREZ VOTRE ARTICLE EN LIGNE CHEZ NOUS À WWW.LIFETIME.COM

À Lifetime, nous sommes engagés à fournir des produits innovants et de qualité. Lors de l'enregistrement, vous aurez l'occasion de nous donner votre avis. Vos remarques sont précieuses pour nous.

- Vous pouvez aussi vous engager pour recevoir notifications d'articles nouveaux et promotions.
- En cas improbable de retrait de produit du marché ou de modification affectant la sécurité, votre enregistrement nous fournit l'information nécessaire de vous contacter directement.
- L'enregistrement est rapide, simple, et complètement volontaire.

LA PROMESSE DE LIFETIME À VOUS :

À Lifetime, l'entretien de votre confidentialité est notre politique de longue date. Et vous pouvez être sûr que Lifetime ne vendra pas ni fournira pas vos données personnelles à d'autres tiers, ou les permettra d'utiliser vos données personnelles à leur propres fins.

Nous vous invitons à lire notre politique de confidentialité à www.lifetime.com

ENREGISTREZ aujourd'hui !



SAFETY INSTRUCTIONS



FAILURE TO FOLLOW THESE WARNINGS MAY RESULT IN SERIOUS INJURY OR PROPERTY DAMAGE AND WILL VOID WARRANTY.

To ensure safety, do not attempt to assemble this product without following the instructions carefully. Check entire box and inside all packing material for parts and/or additional instruction material. Before beginning assembly, read the instructions and identify parts using the hardware identifier and parts list in this document. Proper and complete assembly, use and supervision are essential to reduce the risk of accident or injury.

- Do not use or store hot objects such as grills, blowtorches, welding equipment, etc. near the product.
- If using a ladder during assembly, use extreme caution.
- Two capable adults are required for assembly. (It is also recommended that a third adult function as an instruction reader.)

Most injuries are caused by misuse and/or not following instructions. Use caution when using this product.



INSTRUCCIONES DE SEGURIDAD



EL INCUMPLIMIENTO DE SEGUIR ESTAS ADVERTENCIAS PUEDE RESULTAR EN LESIONES GRAVES O DAÑO A LA PROPIEDAD Y ANULARÁ LA GARANTÍA.

Para asegurar la seguridad, no intente armar este producto sin seguir detenidamente las instrucciones. Inspeccione la caja entera y toda la materia de embalaje para materia y/o partes adicionales. Antes de comenzar el armado, lea las instrucciones e identifique las partes usando los Identificadores de accesorios y piezas en este documento. El armado propio y completo, el uso correcto, y supervisión son esenciales para reducir el riesgo de accidentes y lesiones.

- No use ni almacene objetos calientes tales como las parrillas, los sopletes, el equipo de soldadura, etc. en el cobertizo.
- Si utiliza una escalera durante el ensamble, tenga cuidado extremo.
- Dos adultos competentes son requeridos para ensamblar el cobertizo. (Se sugiere que un tercer adulto funciona como el lector de las instrucciones.)

La mayoría de las lesiones son causadas por el uso erróneo y/o el incumplimiento de seguir las instrucciones. Tenga cuidado al usar este cobertizo.



INSTRUCTIONS DE SÉCURITÉ



LA NON-RESPECT DE CES AVERTISSEMENTS PEUT ENTRAÎNER EN CONSÉQUENCE DES BLESSURES SÉRIEUSES OU L'ENDOMMAGE À LA PROPRIÉTÉ ET ANNULERA LA GARANTIE.

Pour assurer votre sécurité, n'attendez pas de monter cet élément sans suivre attentivement les instructions. Vérifiez les boîtes entières et l'intérieur de tout le matériel pour les pièces et/ou matériel d'instruction additionnel. Avant de commencer le montage, lisez les instructions et identifiez les pièces en utilisant l'Identificateur d'accessoires et de pièces dans ce document. Le montage propre et complète, l'usage correct, et la supervision sont essentiels pour réduire le risque des hasards ou des blessures.

- N'utilisez pas ni conservez pas les objets chauds telles comme les grilloirs, lampes à souder, équipement à souder, etc. sur cet élément.
- Si vous utilisez une échelle pendant le montage, utilisez-la avec prudence.
- Deux adultes capables sont requis pour monter cet élément. (Nous recommandons qu'une troisième personne fonctionne comme lecteur des instructions.)

La plupart des blessures sont causées par l'abus et/ou par ne pas suivre les instructions. Faites attention lorsque vous utilisez cet abri.



INSTRUÇÕES DE SEGURANÇA



DEIXAR DE SEGUIR ESTAS ADVERTÊNCIAS PODERÁ PROVOCAR LESÕES GRAVES OU DANOS À PROPRIEDADE E ANULARÁ A GARANTIA.

Para manter a segurança, não tente montar este sistema sem seguir atentamente as instruções. Inspeccione toda a caixa e o conteúdo do material de embalagem para localizar as peças e/ou materiais com instruções adicionais. Antes de iniciar a montagem, leia as instruções e identifique as peças usando o identificador das ferragens e a lista de peças existentes neste documento. O uso, a montagem, e a supervisão adequados e completos são fundamentais para diminuir o risco de acidente ou lesão. Existe uma grande probabilidade de lesão grave se não se montar, manter e operar este sistema de modo adequado.

- Não utilize ou guarde objetos quentes, tais como grelhas, maçaricos, equipamentos de solda, etc. perto do produto.
- Se estiver usando uma escada durante a montagem, de utilização extrema cautela.
- Recomenda-se a participação de dois adultos capacitados na montagem.

A maioria das lesões decorre do uso inadequado e/ou de não seguir as instruções. Tome cuidado ao usar este sistema.



SICHERHEITSINFORMATIONEN



WENN DIESE WARNUNGEN NICHT BEFOLGT WERDEN, KANN ES ZU SCHWERWIEGENDEN VERLETZUNGEN ODER SACHSCHÄDEN KOMMEN UND DIE GARANTIE WIRD AUSSER KRAFT GESETZT.

Um Ihre Sicherheit zu gewährleisten, sollten Sie nicht versuchen, das Produkt aufzubauen, ohne dabei die Anleitungen sorgfältig zu befolgen. Suchen Sie in der gesamten Kiste und in dem Verpackungsmaterial nach Teilen und/oder zusätzlichen Anleitungen. Bevor Sie mit der Montage beginnen, lesen Sie bitte alle Anleitungen und identifizieren die Teile aufgrund der Eisenwarenliste und der Stückliste in diesem Dokument. Der korrekte und vollständige Zusammenbau sowie der korrekte Gebrauch und die richtige Kontrolle ist dabei ausschlaggebend, das Unfallrisiko und Verletzungsrisiko zu reduzieren.

- Benutzen oder lagern Sie keine heißen Objekte, wie zum Beispiel Grillgeräte, Schneidbrenner, Schweißgeräte, etc. in der Nähe des Produkts.
- Seien Sie besonders vorsichtig, wenn Sie während der Montage eine Leiter benutzen.
- Für die Montage werden zwei fähige Erwachsene benötigt. (Es ist außerdem empfehlenswert, dass ein dritter Erwachsener vor Ort ist, der die Anleitungen vorliest.)

Die meisten Unfälle passieren durch den Fehlgebrauch und das Nichtbefolgen der Anleitungen. Seien Sie vorsichtig, wenn Sie dieses Produkt benutzen.



VEILIGHEIDSAANWIJZINGEN



ALS U VERZUIMT DEZE WAARSCHUWINGEN IN ACHT TE NEMEN, ZIJN ERNSTIG LETSEL EN/OF SCHADE AAN EIGENDOM MOGELIJK; VERDER KOMT IN DIT GEVAL DE GARANTIE TE VERVALLEN.

Belangrijke veiligheidsaanwijzing: bij het in elkaar zetten van dit product moeten alle aanwijzingen nauwgezet worden nagevolgd. Controleer de hele doos en alle verpakkingsmaterialen op onderdelen en/of verdere aanwijzingen. Alvorens te beginnen met het in elkaar zetten, wordt u geacht de aanwijzingen te lezen en de diverse onderdelen te identificeren aan de hand van de identificatielijst voor bevestigingsmaterialen en de onderdelenlijst die deel uitmaken van dit document. Teneinde het risico van ongelukken of letsel te verlagen, is het van essentieel belang dat de berging juist en volledig in elkaar wordt gezet en gebruikt en dat hierbij voldoende supervisie wordt geboden.

- Hete voorwerpen zoals grills, branders, lasapparatuur, enz. mogen nooit in de omgeving van het product worden gebruikt of opgeslagen.
- Als u tijdens het in elkaar zetten gebruik maakt van een ladder, ga dan uiterst voorzichtig te werk
- Voor het in elkaar zetten van de berging zijn twee competente volwassenen nodig. (Verder verdient het aanbeveling een derde volwassene beschikbaar te hebben, die de aanwijzingen voorleest.)

Als mensen zich bezeren, komt dit meestal door verkeerd gebruik en/of het niet opvolgen van de aanwijzingen. Ga altijd uiterst voorzichtig te werk bij het gebruik van dit product.



安全の手引き



以下の警告に従わなければ、深刻なケガまたは物的損害が生じ、保証が無効になる場合があります。

安全を保証するため、すべての説明をお読みになっていない状態で指示に従わずに本製品を組み立てようとししないでください。部品や追加の説明書が入っていないか、箱全体とあらゆる梱包資材の中をチェックしてください。組立てを開始する前に、本書内の部品およびハードウェア・リストおよび識別記号を使用して、すべての部品とハードウェアが揃っていることを確認してください。適切な設置、そして事故またはケガの危険性を軽減するためには、正しく完全な組立て、使用、および監督が不可欠です。この製品が適切に取付け、維持および/または管理されない場合、高い確率で深刻なケガが発生します。本説明書に記載されている警告に従わない場合、切り傷、骨折、神経損傷、麻痺、脳損傷、または死などの深刻な身体傷害が生じる場合があります。また、警告に従わない場合は、物的損害が生じる可能性もあります。すべての警告と注意をよくお読みください。

- シェッド内に、グリル、プロトーチ、溶接装置、その他など、熱を持つものを使用または保存しないでください。
- 組立て時にはしごを使用する場合、細心の注意を払ってください。
- シェッドの組立てには、2人の作業可能な大人が必要です。(3人目の大人が説明書を読む係を担当することを推奨します。)

ほとんどのケガは、誤用や指示に従わないことが原因で発生します。本製品を使用するときは、十分注意を払ってください。



안전지침



아래의 경고사항들을 따르지 않으시면 심각한 부상 또는 자산의 손상을 입을 수도 있으며 보증은 무효가 될 것입니다.

안전을 위해, 이 제품의 조립 시에는 지침을 주의 깊게 따르십시오. 부품 및/또는 부가적인 지침 자료를 전체 박스와 모든 포장 자재의 내부에서 확인하십시오. 조립을 시작하시기 전에, 지침을 읽으시고 이 자료에 수록된 하드웨어 확인항목 및 부품 리스트를 이용해서 부품들을 확인하십시오. 사고 또는 부상의 위험을 줄이기 위해서는 적절하고 완전한 조립, 사용과 감독이 필수적입니다.

- 제품 근처에서는 그릴, 소형 발열장치, 용접장비 등과 같은 뜨거운 물체를 보관하거나 사용하지 마십시오.
- 조립 시에 사다리를 사용하실 때는 극도로 주의를 기울이십시오.
- 작업이 가능한 두 명의 성인이 조립 시에 필요합니다. (지침을 읽어 줄 세 번째 성인의 역할도 권고합니다.)

대부분의 부상은 지침을 잘못 사용하거나/또는 따르지 않아 비롯됩니다. 이 제품을 사용하실 때는 주의를 기울이십시오.



Questions or Missing Parts? ID:

TO SAVE TIME WHEN CONTACTING CUSTOMER SERVICE, PLEASE HAVE THE PRODUCT ID AVAILABLE BEFORE YOU CALL; IT'S LOCATED AT THE BOTTOM-LEFT CORNER OF THE FRONT PAGE OF THIS MANUAL.

****U.S. and Canada customers ONLY****

FOR CUSTOMERS OUTSIDE THE U.S. OR CANADA, PLEASE CONTACT THE STORE FOR ASSISTANCE.

DO NOT CONTACT THE STORE!
CALL OUR CUSTOMER SERVICE DEPARTMENT at
1 (800) 225-3865

HOURS: 7:00 a.m. to 5:00 p.m. Monday through Friday (Mountain Standard Time)

Call, or visit our Web site for Saturday hours



Preguntas, Faltan Piezas? ID:

PARA AHORRAR TIEMPO CUANDO SE PONE EN CONTACTO CON NUESTRO SERVICIO A CLIENTES, FAVOR DE TENER LA IDENTIFICACIÓN DEL PRODUCTO DISPONIBLE ANTES DE LLAMAR; ESTÁ UBICADO EN LA ESQUINA INFERIOR IZQUIERDO DE LA PRIMERA PÁGINA DE ESTE MANUAL.

****Clientes de los E.U.A. o de Canadá SOLAMENTE****

PARA LOS CLIENTES AFUERA DE LOS ESTADOS UNIDOS O DE CANADÁ, PÓNGASE EN CONTACTO CON LA TIENDA POR FAVOR.

¡NO CONTACTE LA TIENDA!
LLAME A NUESTRO DEPARTAMENTO DE SERVICIOS A CLIENTES al
1.800.225.3865

HORAS: 0700-1700 lunes a viernes (HNR)

Llámenos, o visítenos a nuestra página en Internet para las horas de sábado



Questions, Pièces Manquantes ? ID:

POUR GAGNER DU TEMPS SI VOUS CONTACTEZ NOTRE DÉPARTEMENT DE SERVICES À CLIENTÈLE, VEUILLEZ TENIR LE NUMÉRO D'IDENTIFICATION DISPONIBLE AVANT D'APPELER; C'EST SITUÉE AU COIN INFÉRIEURE GAUCHE DE LA PREMIÈRE PAGE DE CE MANUEL.

****Clientes des États-Unis et du Canada SEULEMENT****

CLIENTS AU-DEHORS DES ÉTATS-UNIS ET DU CANADA, VEUILLEZ CONTACTER LE MAGASIN POUR OBTENIR ASSISTANCE.

NE CONTACTEZ PAS LE MAGASIN !
APPELÉZ NOTRE DÉPARTEMENT DE SERVICE À CLIENTÈLE au
1.800.225.3865

HEURES : 0700-1700 lundi-vendredi (HNR)

Appelez-nous, ou rendez visite à notre site Web pour obtenir les heures de samedi



• Consult all local building codes, as well as city and county ordinances, to ensure that the construction of the Outdoor Shed does not require a building permit. Proper building permit documentation may be required in your neighborhood, and it would be unfortunate to learn this after constructing the Shed.

• Consulte todos los códigos locales de construcción y los reglamentos de la ciudad y el municipio para asegurarse de que la construcción del cobertizo no requiere un permiso de construcción. Puede suceder que en su vecindario se requiera la documentación apropiada de un permiso de construcción, y sería desafortunado enterarse de esto luego de haber construido el cobertizo.

• Consultez tous les codes du bâtiment locaux, ainsi que les décrets des villes et comtés, pour vérifier que la construction de l'abri extérieur n'exige pas un permis de construire. Il est possible que votre quartier exige une documentation visant les permis de construire et il serait dommage d'apprendre cela alors que votre abri est déjà construit.

• Consulte todas as normas de construção locais, assim como as posturas camarárias e regulamentos nacionais de forma a assegurar que a construção do Abrigo Exterior não requer nenhuma licença de construção. Poderá ser necessário obter documentação de autorização de construção no seu bairro e seria realmente desagradável descobrir isto depois de montar o seu Abrigo.

• Informieren Sie sich über alle örtlichen baurechtlichen Vorschriften sowie Stadt- und Bezirksverordnungen, um sicherzustellen, dass Sie für den Bau Ihres Lagerschuppens keine Baugenehmigung benötigen. Es könnte sein, dass in Ihrem Wohngebiet entsprechende Dokumentationen für die Baugenehmigung erforderlich sind und es wäre eine Schande, wenn Sie das erst erfahren, nachdem Sie Ihren Lagerschuppen bereits aufgebaut haben.

• Raadpleeg alle plaatselijke bouwcodes en andere voorschriften om u ervan te overtuigen dat u voor het in elkaar zetten van de buitenberging geen bouwvergunning nodig hebt. In uw buurt is hiervoor wellicht een bouwvergunning vereist, en het zou heel jammer zijn om hierachter te komen nadat u uw buitenberging in elkaar hebt gezet.

• 屋外シェッドの建築に建築許可が必要でないことを確認するために、市や自治体の条例に加え、あらゆる地域建築規制を調べてください。適切な建築許可文書が、お客様の地域で必要である場合があります。もし、シェッドを組み立てた後にそれが分かたら残念なことになってしまいます！

• 옥외 간이창고를 설치할 때 건축허가가 필요하지 않으니 시와 카운티의 규정은 물론 모든 로컬 건축 코드도 확인하시기 바랍니다. 귀하의 동네에서 적절한 건축허가 서류를 요구할 수도 있으며, 간이창고가 설치된 후에 알게 되시면 불편을 겪으실 수도 있기 때문입니다.

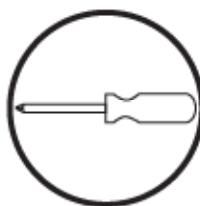

• You may use a #2 Phillips head screwdriver bit and a power screwdriver or drill, instead of a hand screwdriver. However, be aware that the plastic pieces of your Shed can be damaged by overtightening of screws. To avoid damage we strongly recommend the use of a low-powered power screwdriver or a drill that has an adjustable clutch that is set on a low torque setting. If neither is available, use a hand screwdriver. In any case use caution to avoid overtightening the screws.

• Hay una punta de destornillador Phillips #2 incluida con los elementos del cobertizo. Esta punta puede usarse con cualquier destornillador o taladro eléctrico. Las piezas de plástico de su cobertizo pueden dañarse si se aprietan demasiado los tornillos. Para evitar daños, recomendamos usar un destornillador eléctrico de baja potencia o un taladro que tenga un embrague regulable y pueda colocarse en una posición de baja velocidad. Si no dispone de ninguna de estas herramientas, use un destornillador manual. En todos los casos, cuide de no apretar demasiado los tornillos.

• Les accessoires fournis avec un abri comprennent un tournevis à embout Phillips N° 2. Cet embout peut être utilisée avec tout tournevis ou perceuse électrique. Les sections en plastique de l'abri risquent d'être endommagées si les vis sont trop serrées. Pour éviter ceci, nous recommandons fermement d'utiliser un tournevis ou perceuse électriques de faible puissance, à embrayage réglable réglé sur faible couple. Si ces outils ne sont pas disponibles, utilisez un tournevis manuel. Dans tous les cas, évitez de trop serrer les vis.

• Pode utilizar uma broca tipo Phillips n.º 2 e uma chave de fendas automática ou um berbequim em vez de uma chave de fendas manual. Contudo, tenha atenção em relação às peças de plástico do seu Abrigo que podem ser danificadas se apertar os parafusos em excesso. Para evitar este tipo de problemas, recomendamos a utilização de uma chave de fendas automática de baixa rotação ou um berbequim com uma patilha ajustável para poder obter um binário reduzido. Se não tiver nenhuma destas ferramentas disponíveis, utilize uma chave de fendas manual. Em qualquer dos casos, tenha extremo cuidado para evitar apertar os parafusos em demasia.

• Sie dürfen anstelle eines Handschraubenziehers auch einen Nr. 2 Kreuzschraubenziehereinsatz und einen elektrischen Schraubenzieher oder eine Bohrmaschine benutzen. Beachten Sie aber bitte, dass die Plastikteile Ihres Schuppens beschädigt werden können, wenn Sie die Schrauben zu fest anziehen. Um solche Schäden zu verhindern, empfehlen wir, dass Sie einen elektrischen Schraubenzieher mit geringer Leistung oder eine Bohrmaschine mit einer einstellbaren Kupplung und einer niedrigen Drehmomenteinstellung verwenden. Falls Sie diese Geräte nicht zur Hand haben, können Sie einen Handschraubenzieher benutzen. Verfahren Sie in jedem Fall mit Vorsicht, um die Schrauben nicht zu fest anzuziehen.

• In plaats van een handmatige schroevendraaier kunt u een kruiskopschroevendraaierbit nr. 2 en elektrische schroevendraaier of boor gebruiken. Wees er echter op attent dat de plastic onderdelen van de berging beschadigd kunnen raken als de schroeven te strak worden aangedraaid. Om beschadiging te vermijden, raden wij u sterk aan een niet al te sterke elektrische schroevendraaier te gebruiken of een boor met verstelbare koppeling, en deze op een lager toerental in te stellen. Mocht u geen van beide ter beschikking hebben, gebruik dan een gewone handmatige schroevendraaier. Wees hoe dan ook altijd voorzichtig dat u de schroeven niet te strak aandraait.

• 手動のドライバーの代わりに、#2プラスドライバー・ビットと電動ドライバーまたはドリルを使用することができます。ただし、お客様のシェッドのプラスチック部分がネジの締め過ぎにより損傷する可能性があることを覚えておいてください。この損傷を避けるために、低出力電動ドライバーまたは低トルクに設定された調整可能なクラッチ付きのドリルを使用されることを強くお勧めします。どちらもお持ちでない場合は、手動のドライバーを使用してください。いずれにせよ、ネジの締め過ぎを避けるために、注意してください。

• 일반 스크루 드라이버 대신에 #2 필립스 헤드 스크루 드라이버 비트를 사용하셔도 됩니다. 하지만 간이창고의 플라스틱 부위는 스크루를 너무 세게 조이면 손상될 수도 있으니 주의하시기 바랍니다. 그러한 손상을 방지하기 위해 출력력이 낮은 파워 스크루 드라이버 또는 낮은 토크로 설정이 된 조절이 가능한 클러치가 장착된 드릴의 사용을 강력히 추천합니다. 다른 것들이 준비되어 있지 않으면 일반 스크루 드라이버를 사용하십시오. 어떠한 경우에도 스크루를 너무 세게 조이지 마십시오.



- Surface must be leveled before installation. We recommend building a level work space with a concrete or patio style surface. If the surface is not properly leveled, the Outdoor Shed will not assemble correctly. Proper surface leveling will save you time in the long run, so please do not ignore this step.
- La superficie debe estar nivelada antes de comenzar el armado. Recomendamos preparar un espacio de trabajo nivelado con una superficie de concreto o de tipo patio. Si la superficie no está nivelada de manera adecuada, el cobertizo para exteriores no podrá armarse correctamente. La nivelación de la superficie le ahorrará tiempo de trabajo, por lo tanto, le pedimos que no ignore este paso.
- La surface d'installation doit être de niveau. Nous recommandons de construire un espace de travail de niveau en béton ou de genre patio. Si la surface n'est pas correctement de niveau, l'assemblage de l'abri extérieur ne se fera pas correctement. Vous gagnerez du temps sur le long terme grâce à une surface bien de niveau, ne négligez donc pas cette étape.

• A superfície deverá ser nivelada antes da instalação. Recomendamos a construção de um espaço de trabalho nivelado com uma superfície em betão ou tipo pátio. Caso a superfície não seja bem nivelada, o Abrigo Exterior não ficará corretamente montado. O nivelamento de superfície adequado poupará-lhe o tempo a longo prazo, pelo que não deverá ignorar este passo.

• Der Untergrund muss vor Beginn der Montagearbeiten eingeebnet werden. Wir empfehlen, dass Sie einen ebenerdigen Arbeitsplatz schaffen, der über eine Zement- oder Terrassenoberfläche verfügt. Wenn die Oberfläche vorab nicht korrekt geebnet wird, lässt sich der Lagerschuppen nicht korrekt zusammenbauen. Das sorgfältige Ebnen der Arbeitsoberfläche spart Ihnen langfristig gesehen Zeit. Bitte ignorieren Sie diesen Schritt daher nicht.

• Voordat de berging in elkaar wordt gezet, moet het oppervlak waterpas worden gemaakt. Een waterpas staande werkplek met een oppervlak van beton, zoals een patio, verdient de voorkeur. Als het werkoppervlak niet waterpas staat, resulteert dit in problemen tijdens het in elkaar zetten van de buitenberging. Het waterpas maken van het werkoppervlak zal u op lange termijn tijd besparen, dus deze stap moet niet worden overgeslagen.

• 設置前に、設置面を水平にしておく必要があります。コンクリートまたはパティオ形式の設置面を使用して水平な作業場を構築することを推奨します。設置面が正しく水平に調整されていない場合は、屋外シェッドを正しく組み立てることができません。設置面を水平に調整することが、長い目で見て時間を節約することになりますので、このステップを無視しないでください。

• 설치하기 전에 표면을 평탄하게 만들어야 합니다. 콘크리트 또는 패티오 스타일의 표면에 평탄한 공간을 만드시기를 권해 드립니다. 만일 표면이 충분히 평탄하지 않으면 이 간이창고는 제대로 조립되지 않을 것입니다. 충분한 표면 정리작업은 장기적으로 시간을 절약할 수 있으니 이 절차를 무시하지 마십시오.



- If you plan on anchoring your shed, you must purchase the correct anchoring hardware for the type of platform chosen: concrete, wood, or road base. The anchoring hardware used depends on the platform. If you have a concrete platform, we recommend using a hammer drill, 5/16" (7,9 mm) masonry bit, four (4) 3/8" x 2" (9,5 mm x 5,1 cm) Concrete Screws and four (4) 3/8" x 1" (9,5 mm x 2,54 cm) Fender Washers. If you have a wood-framed platform, we recommend using a drill, 5/16" (7,9 mm) drill bit, four (4) 3/8" x 1 1/2" (9,5 mm x 3,81 cm) Lag Screws and four (4) 3/8" x 1" (9,5 mm x 2,54 cm) Fender Washers. **Do not exceed a 3/8" diameter screw. Refer to your local hardware store for this hardware.**

• Si piensa anclar su cobertizo, es necesario comprar los elementos de anclaje correctos para el tipo de plataforma escogido: concreto, madera, o base granular. Los elementos de anclaje usados dependen de la plataforma. Si tiene una plataforma hecho de concreto, recomendamos que use un martillo perforador, broca de albañilería de 7,9 mm (5/16"), cuatro (4) Tornillos de anclaje para concreto de 9,5 mm x 5,1 cm (3/8" x 2") y cuatro (4) Rondanas de protección de 9,5 mm x 2,54 cm (3/8" x 1"). Si tiene una plataforma hecho de madera, recomendamos que use un taladro eléctrico, una broca de 7,9 mm (5/16"), cuatro (4) Tornillos para madera de 9,5 mm x 3,81 cm (3/8" x 1 1/2") y cuatro (4) Rondanas de protección de 9,5 mm x 2,54 cm (3/8" x 1"). **No exceda un diámetro de 9,5 mm (3/8"). Refiérase a su ferretería local para obtener estos elementos.**

• Si vous projetez d'ancrer votre abri, il faut acheter les accessoires d'ancrage corrects pour le type de plate-forme que vous avez choisi : béton, bois, ou enrobé de base. Les accessoires d'ancrage utilisés dépendent de la plate-forme. Si vous avez construit une plate-forme en béton, nous recommandons que vous utilisiez un perceuse de percussion, un foret à maçonnerie de 7,9 mm (5/16"), quatre (4) Vis d'ancrage à béton de 9,5mm x 5,1 cm (3/8" x 2") et quatre (4) Rondelles de protection de 9,5mm x 2,54cm (3/8" x 1"). Si vous avez construit une plate-forme en bois, nous recommandons que vous utilisiez une perceuse électrique, un foret de 7,9 mm (5/16"), quatre (4) Vis de retard de 9,5mm x 3,81 cm (3/8" x 1 1/2") et quatre (4) Rondelles de protection de 9,5mm x 2,54cm (3/8" x 1"). **Ne dépassez pas un diamètre de 9,5mm (3/8"). Votre quincaillerie du coin aura ces accessoires.**

• Se pretende ancorar o seu alpendre, deve comprar o material de ancoragem correcto para o tipo de plataforma escolhida: betão, madeira ou base de pavimento. O material de ancoragem utilizado depende da plataforma. Se tiver uma plataforma de betão, recomendamos a utilização de um martelo perfurador, 5/16" (7,9 mm) broca de alvenaria, quatro parafusos para betão (4) 3/8" x 2" (9,5 mm x 5,1 cm) e quatro anilhas (4) 3/8" x 1" (9,5 mm x 2,54 cm). Se tiver uma plataforma de estrutura de madeira, recomendamos a utilização de um berbequim, 5/16" (7,9 mm) broca, quatro parafusos para madeira 3/8" x 1 1/2" (9,5 mm x 3,81 cm) e quatro anilhas (4) 3/8" x 1" (9,5 mm x 2,54 cm). **Não use parafusos com diâmetro superior a 3/8". Consulte a sua loja de ferragens local para obter este material.**

• Wenn Sie Ihren Schuppen verankern möchten, müssen Sie die richtigen Verankerungswerkzeuge und Eisenwaren für den gewählten Plattformtyp kaufen: Beton, Holz oder Straßenbelag. Die zu verwendenden Verankerungswerkzeuge und Eisenwaren richten sich nach der Plattform. Wenn Sie eine Betonplattform haben, empfehlen wir: Bohrhämmer, 7,9 mm (5/16 Zoll) Steinbohrereinsatz, vier (4) 9,5 mm x 5,1 cm (3/8 Zoll x 2 Zoll) Betonschrauben und vier (4) 9,5 mm x 2,54 cm (3/8 Zoll x 1 Zoll) Unterlegscheibe zum Sichern. Wenn Sie eine Holzrahmenplattform haben, empfehlen wir: Bohrer, 7,9 mm (5/16 Zoll) Bohreinsatz, vier (4) 9,5 mm x 3,81 cm (3/8 Zoll x 1 1/2 Zoll) Ankerschrauben und vier (4) 9,5 mm x 2,54 cm (3/8 Zoll x 1 Zoll) Unterlegscheiben zum Sichern. **Der Schraubendurchmesser von 9,5 mm (3/8 Zoll) darf nicht überschritten werden! Erkundigen Sie sich in Ihrem örtlichen Heimwerkergeschäft nach diesen Eisenwaren.**

• Als u van plan bent uw schuur te verankeren, moet u de juiste verankeringsmiddelen kopen voor het door u gekozen platform: beton, hout of grof-aggregaatmengsel (wegfundering). De gebruikte verankeringsmiddelen zijn afhankelijk van het platform. Bij een betonnen platform raden wij het gebruik van een klopboor, een 7,9 mm (5/16") steenboortje, vier (4) 9,5 mm x 5,1 cm (3/8" x 2") betonbouten en vier (4) 9,5 mm x 2,54 cm (3/8" x 1") onderleggingen aan. Bij een platform bestaande uit een houten frame raden wij het gebruik van een boor, een 7,9 mm (5/16") houtboortje, vier (4) 9,5 mm x 3,81 cm (3/8" x 1 1/2") houtschroeven en vier (4) 9,5 mm x 2,54 cm (3/8" x 1") onderleggingen aan. **Gebruik geen bouten c.q. schroeven met een diameter van meer dan 9,5 mm (3/8"). Raadpleeg uw plaatselijke metaalwarenwinkel voor deze bevestigingsmaterialen.**



• 小屋を地面に固定する場合、コンクリート、木材、道路基盤の中から選択した台のタイプに合った固定具を購入してください。固定具は台によって異なります。コンクリートの台を使用される場合は、ハンマードリル、コンクリート用ドリルの歯(5/16インチ (7.9 mm))、コンクリート用ねじ(3/8インチ x 2インチ (9.5 mm x 5.1 cm)) 4本、フェンダーワッシャー(3/8インチ x 1インチ (9.5 mm x 2.54 cm)) 4枚の使用を推奨します。木材で枠取りされた台を使用される場合は、ドリル、ドリルの歯(5/16インチ (7.9 mm))、ラグねじ(3/8インチ x 1 1/2インチ (9.5 mm x 3.81 cm)) 4本、フェンダーワッシャー(3/8インチ x 1インチ (9.5 mm x 2.54 cm)) 4枚の使用を推奨します。直径3/8インチ(9.5 mm)以上のねじを使用しないでください。この金具についてはお近くのホームセンターでお尋ねください。

• 만일 간이창고를 바닥에 고정시킬 계획을 갖고 계시면 플랫폼(콘크리트, 목재 또는 도로 기반)에 적합한 고정을 위한 하드웨어를 구입하셔야 합니다. 콘크리트 플랫폼에는 해머 드릴, 5/16"(7.9mm) 석공용 비트, 네(4) 개의 3/8" x 2"(9.5mm x 5.1cm) 콘크리트 스크루 및 네(4) 개의 3/8" x 1"(9.5mm x 2.54cm) 펜더 와셔의 사용을 추천합니다. 목재 프레임 플랫폼에는 드릴, 5/16"(7.9mm) 드릴 비트, 네(4) 개의 3/8" x 1 1/2"(9.5mm x 3.81cm) 래그 스크루 및 네(4) 개의 3/8" x 1"(9.5mm x 2.54cm) 펜더 와셔의 사용을 추천합니다. 직경3/8" 가 넘는 스크루는 사용하지 마십시오. 이들 하드웨어에 관해 동네의 하드웨어 상점에 문의하십시오.



WARNING

Failure to anchor the shed may result in property damage and/or personal injury.



AVISO

A não ancoragem do abrigo poderá resultar em ocorrência de danos na propriedade e/ou lesões pessoais.



ADVERTENCIA

El incumplimiento de anclar el cobertizo podría ocasionar daño a la propiedad y/o lesiones personales.



WARNUNG

Unterlassen der Verankerung des Schuppens könnte Sachschaden und/oder Körperverletzung nach sich ziehen.



AVERTISSEMENT

Le non-respect d'ancrer votre abri peut résulter en dommage à propriété et/ou blessures graves personnelles.



WAARSCHUWING

Als u verzuimt de berging te verankeren, zijn schade aan eigendom en/of lichamelijk letsel mogelijk.



경고

이 간이창고를 바닥에 고정하지 않으면 자산의 손상 및/또는 신체 부상을 입을 수도 있습니다.



警告

シェッドにアンカーを付けない場合は、物的損害や身体傷害が生じる可能性があります。



• Sharp objects may damage your floor. If resting sharp, heavy objects on your Shed floor, place a block of wood between the sharp object and floor.

• Los objetos afilados pueden dañar su piso. Si debe apoyar objetos puntiagudos y de mucho peso sobre el piso de su cobertizo, coloque un pedazo de madera entre el objeto puntiagudo y el piso.

• Les objets pointus risquent d'endommager votre plancher. Lors de la pose d'objets lourds et pointus sur le plancher de l'abri, placez un bloc de bois entre le plancher et l'objet.

• Os objetos afiados podem danificar o seu soalho. Caso coloque objetos pesados e afiados no soalho do seu Abrigo, coloque um bloco de madeira entre o objeto em causa e o soalho.

• Spitze Gegenstände können Ihren Fußboden beschädigen. Wenn Sie spitze, schwere Gegenstände auf den Boden des Schuppens legen, legen Sie einen Holzklotz zwischen den Fußboden und den spitzen Gegenstand.

• Scherpe voorwerpen kunnen uw vloer beschadigen. Als u scherpe, zware voorwerpen op de vloer van de berging neerlegt, plaats er dan een houten blok tussen.

• 尖った物質は床を損傷することがあります。尖った重いものをシェッドの床に置く場合は、尖った物質と床の間に木材を挟んでください。

• 날카로운 물체가 바닥에 손상을 입힐 수도 있습니다. 날카롭고 무거운 물체를 간이창고 바닥 위에 올려 놓을 때는 나무 조각을 날카로운 물체와 바닥 사이에 받쳐 놓으십시오.



• To help increase the weather resistance of your shed, you'll need three small pieces of wax paper when applying the caulking to the window panel.

• Para ayudar a mejorar la resistencia a la intemperie de su cobertizo, necesitará tres pequeñas hojas de papel parafinado cuando aplique el enmasillado al panel de pared para la ventana.

• Pour aider à améliorer l'étanchéité de votre abri, il faut obtenir trois petites feuilles de papier paraffiné quand vous appliquez le calfeutrage au panneau pour la fenêtre.

• Para ajudar a aumentar a resistência do seu alpendre às condições atmosféricas, necessitará de três pequenos pedaços de papel encerado na aplicação da calafetagem no painel da janela.

• Um die Wetterbeständigkeit Ihres Schuppens zu erhöhen, benötigen Sie drei kleine Stücke Wachsapier für das Abdichten des Fensterrahmens.

• Om de weerbestendigheid van uw schuur te verbeteren, hebt u drie kleine stukjes waspapier nodig als u kit op het raampaneel aanbrengt.

• 小屋の耐天候性を高めるため、窓ガラスにコーキングをする際には3枚の小さなワックスペーパーが必要です。

• 간이창고의 창문 패널에 코킹을 넣을 때 세 조각의 작은 왁스 종이를 사용하면 방수효과를 높일 수 있습니다.

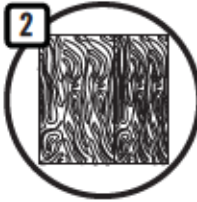

• You must provide a platform on which to assemble your new shed. These instructions explain how to build three types of platforms: **Concrete¹**, **Wood²**, or **Road base-filled wood frame³**. Of these three types of platforms, we highly recommend a concrete platform, second a wood-framed platform, and finally a road base-filled wood frame. **The platform you choose must be built above ground in order to avoid water pooling inside the shed. All lumber must be rated for outdoor use!**

• Es preciso construir una plataforma sobre la cual usted debe ensamblar su nuevo cobertizo. Estas instrucciones explican cómo construir tres tipos de plataformas:

Concreto¹, **Madera²**, o un **Armazón de madera lleno de base granular³**. De estos tres tipos de plataformas, nosotros recomendamos sin reserva que construya una plataforma de concreto. También se puede construir un armazón hecho de madera o un armazón hecho de madera y lleno de base granular. **La plataforma debe ser construida arriba del suelo para evitar el aflujo de agua dentro del cobertizo. ¡Toda la madera debe estar clasificada para el uso externo!**

• Il faut construire une plate-forme sur laquelle vous devez assembler votre nouvel abri. Ces instructions expliquent comment construire trois types de plate-formes : **Béton¹**, **Bois²**, ou **Charpente en bois remplie avec enrobé de base³**. De ces trois types de plate-formes, nous recommandons premièrement que vous construisiez une plate-forme en béton, secondement une Charpente en bois, et troisièmement une Charpente en bois remplie avec enrobé de base. **La plate-forme que vous choisissez doit être construite au-dessus du sol afin d'éviter l'accumulation d'eau à l'intérieur de l'abri. Tous le bois d'oeuvre doit être approuvé pour l'usage à l'extérieur !**

• Deve preparar uma plataforma sobre a qual montar o seu novo alpendre. Estas instruções explicam como montar estes três tipos de plataformas: **Betão¹**, **Madeira²** ou **Estrutura de madeira cheia com base de pavimento³**. Destes três tipos de plataformas, recomendamos vivamente uma plataforma de betão, em segundo uma plataforma de estrutura de madeira e finalmente a estrutura de madeira cheia com base de pavimento. **A plataforma que escolhe deve ser construída acima do solo para evitar a acumulação de poças de água no interior do alpendre. Toda a madeira deve ser adequada para a utilização exterior!**

• Sie müssen eine Plattform bereitstellen, auf der Sie Ihren Schuppen errichten. Diese Anleitungen erläutern den Bau von drei verschiedenen Plattformtypen: **Beton¹**, **Holz²**, oder mit **Straßenbelag gefüllter Holzrahmen³**. Von diesen drei Plattformtypen empfehlen wir zuerst eine Betonplattform, zweitens eine Holzrahmenplattform und schließlich einen mit Straßenbelag gefüllten Holzrahmen. **Die von Ihnen gewählte Plattform muss oberirdisch gebaut werden, um das Ansammeln von Wasser im Schuppen zu verhindern. Alle verwendeten Holzteile müssen für die Verwendung im Freien geeignet sein!**

• U moet zorgen voor een platform waarop u uw nieuwe schuur opbouwt. Deze instructies leggen uit hoe u drie soorten platforms kunt bouwen: **beton¹**, **hout²** of **hout gevuld met grof-aggregaatsmengsel³**. Van deze drie soorten platforms kunt u het beste eerst een betonnen platform kiezen, daarna een platform bestaande uit een houten frame en als laatste een met grof-aggregaatsmengsel gevuld houten frame. **Het door u gekozen platform moet bovengronds worden gebouwd om ophoping van water in de schuur te voorkomen. Al het gebruikte hout moet voor buiten geschikt zijn!**

• 新しい小屋の組み立てには台が必要です。この説明書には次の3つのタイプの台の作り方を説明します。**コンクリート¹**、**木材²**、**木枠付き道路基盤³**。これら3種の台の内、最もお勧めするのはコンクリートの台、2番目は木材の台、最後は木枠付き道路基盤です。**選択した台は地面よりも高く作り、小屋の中に水がたまらないようにしてください。使用する木材は全て屋外用のものにしてください。**

• 귀하의 새로운 간이창고를 설치하기 위한 플랫폼이 필요합니다. 세 가지 종류의 플랫폼을 설치하는 방법에 관한 설명입니다: 콘크리트(1), 목재(2) 또는 도로 바닥으로 채워진 목재 프레임(3). 이들 세 종류의 플랫폼 중에서 콘크리트 플랫폼을 우선적으로 추천하며, 두 번째로는 목재 프레임 플랫폼, 그리고 마지막으로 도로 바닥으로 채운 목재 프레임 순입니다. 선택하신 플랫폼은 반드시 지상 위에 설치되어야 간이창고 안으로의 침수를 피할 수 있습니다. 사용되는 목재는 모두 옥외용이어야 합니다!



• If more than six (6) inches of snow accumulate on the roof of the shed, carefully remove the snow to avoid possible roof collapse. While standing on the ground, remove the snow from the roof with a broom or snow shovel. Do not stand on the roof to remove snow.

• Si acumula más de 15,24 cm de nieve sobre el techo del cobertizo, quítela cuidadosamente para evitar cualquier derrumbe del techo. Párese en el suelo y retire la nieve del techo con una escoba o pala. ¡No se pare en el techo para quitar la nieve!

• Si plus de 15,24 cm de neige accumulent sur le toit de l'abri, enlevez-la soigneusement pour éviter un possible effondrement du toit. Pendant que vous vous mettez sur la terre, enlevez la neige du toit avec un balai ou une pelle. Ne vous mettez-vous sur le toit pour enlever la neige.

• Caso verifique a acumulação de 15 cm (6 polegadas) de neve no telhado do seu abrigo, retire a neve cuidadosamente para evitar um possível colapso do telhado. Mantendo-se sobre o solo, retire a neve do telhado com uma vassoura ou pá. Não se coloque sobre o telhado para retirar a neve.

• Falls sich über sechs (6) Zoll Schnee auf dem Dach Ihres Schuppens ansammeln sollten, entfernen Sie den Schnee bitte vorsichtig, um ein mögliches Einstürzen des Dachs zu vermeiden. Entfernen Sie den Schnee mit einem Besen oder einer Schneeschaukel vom Dach, wobei Sie auf dem Boden stehen. Stellen Sie sich nicht auf das Dach, um den Schnee zu entfernen.

• Als er zich op het dak van de berging meer dan 15 cm sneeuw ophoopt, dient u de sneeuw voorzichtig te verwijderen om instorting van het dak te voorkomen. Hierbij dient u op de grond te staan en de sneeuw met een bezem of sneeuwschep van het dak te verwijderen. Verwijder de sneeuw nooit terwijl u op het dak staat.

• 6インチを超える雪がシェッドの屋根の上に積もった場合、屋根崩壊を回避するために、慎重に雪を除去してください。地面に立ったまま、ホウキまたは除雪用シャベルを使用して屋根から雪を除去してください。除雪するために屋根の上には上がらないでください。

• 만일 육(6) 인치 이상의 눈이 간이창고의 지붕 위에 쌓이면 붕괴를 막기 위해 조심스럽게 눈을 치워야 합니다. 지상에서 빗자루 또는 제설삽으로 지붕의 눈을 치우십시오. 눈을 치우기 위해 지붕 위에 올라가지 마십시오.



REQUIRED TOOLS / HERRAMIENTAS REQUERIDAS / OUTILS REQUIS / FERRAMENTAS NECESSÁRIAS / BENÖTIGTE WERKZEUGE / BENODIGD GEREEDSCHAP / 必要工具 / 필수장비들 / 組裝所需的工具

7/16" (11 mm)

3/8" (10 mm)

2" x 4" x 8'
5,1 cm x 10,2 cm x 2,44 m



(2)



(1)



(1)



(1)



(1)



(1)



(1)



(1)



(3)



(1)

6' (1,83 m)



(2)



(1)



OPTIONAL TOOLS / HERRAMIENTAS OPCIONALES / OUTILS OPTIONNELS / FERRAMENTAS OPCIONAIS / WAHLWEISE WERKZEUGE / OPTIONELE GEREEDSCHAP / オプションの工具 / 선택장비들 / 組裝所需的工具

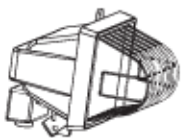

(1)



(1)



(1)

5/16" (7,9 mm)

5/16" (7,9 mm)



(1)



(1)



1



BDI (x1)

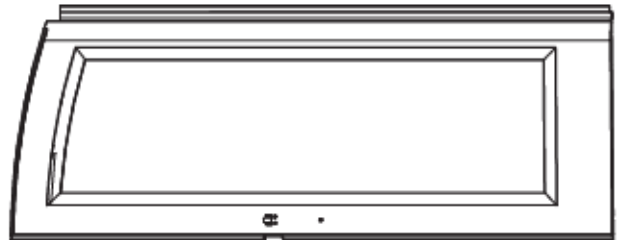

BDK (x1)



BDC (x1)

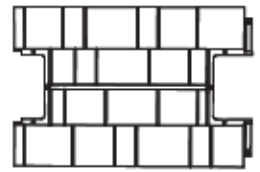

AFY (x3)

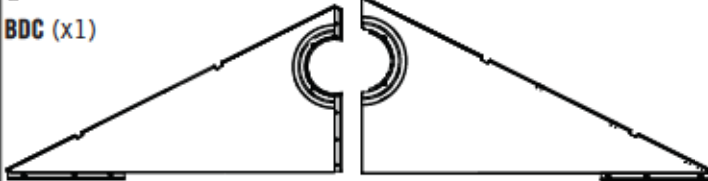

AGI (x2)

AGH (x2)

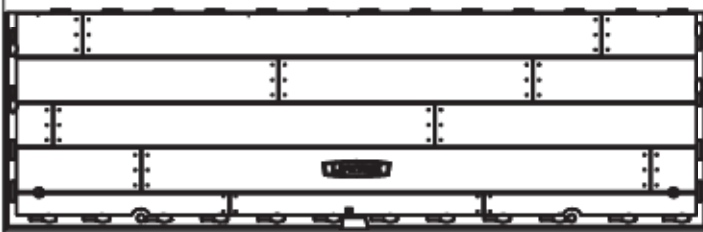

CUW (x2)

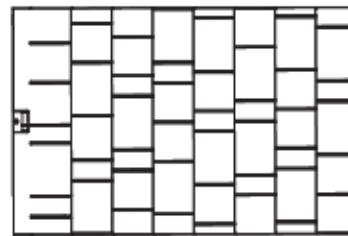

AGQ (x4)

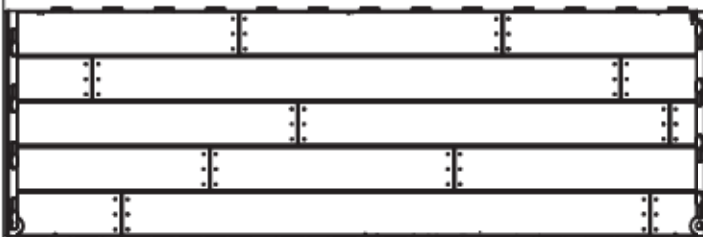

CUD (x2)

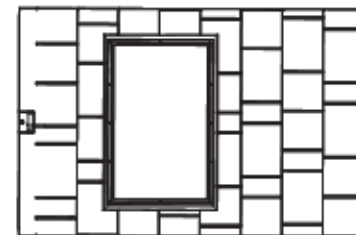

AHB (x2)

AFV (x2)

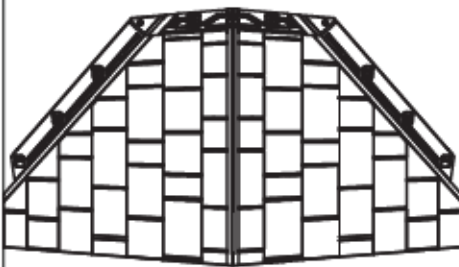

DRA (x1)

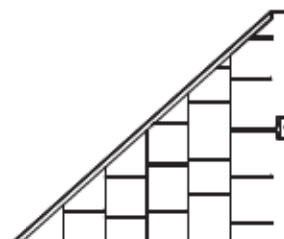

BDR (x1)

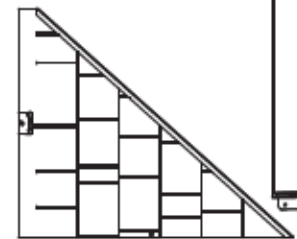

BDS (x1)



DYO

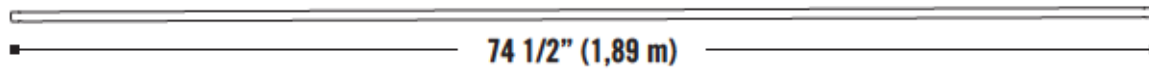

CRE (x2)

74 1/2" (1,89 m)

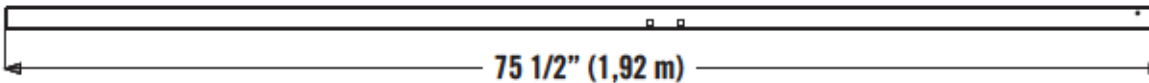

BLH (x2)

75 1/2" (1,92 m)

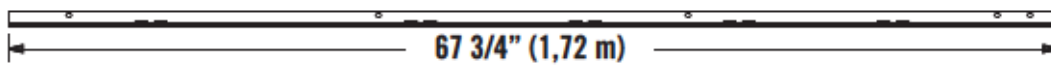
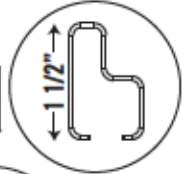

AFM (x6)

67 3/4" (1,72 m)

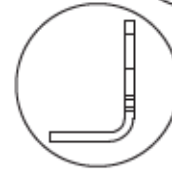

DSP (x1)

58 1/4" (1,48 m)



33 3/4" (85,7 cm)

DSO (x1)

DXI

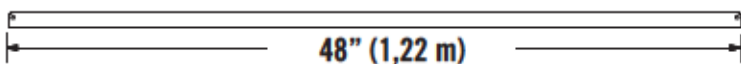

AFG (x3)

48" (1,22 m)

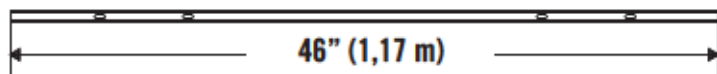
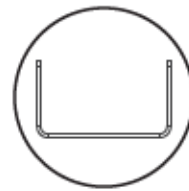

BDD (x1)

46" (1,17 m)

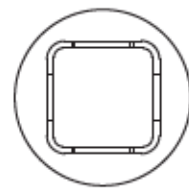

DSQ (x2)

50 9/16 (1,28 m)



DSR (x3)

50 9/16 (1,28 m)



23 9/16" (59,9 cm)

DSM (x1)



2

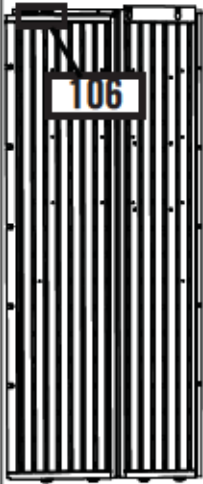

AGW (x2)

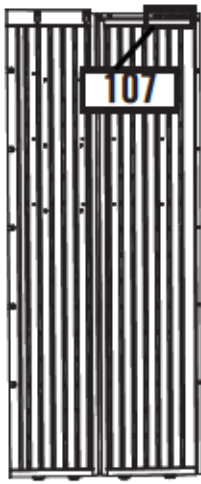

AGL (x2)



AHD (x6)



AHH (x1)



BDI (x1)



BDH (x1)



BDV (x2)



AHE (x1)

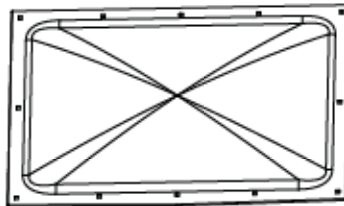

AGB (x2)

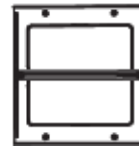

AHC (x4)



AFZ (x2)

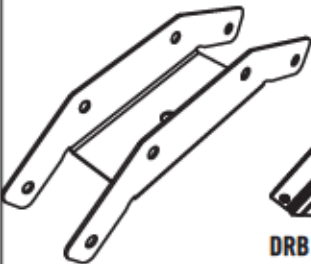

AIP (x3)



DRB (x1)



AGG (x1)

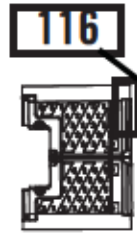

AFW (x1)



8 7/16" (21,4 cm)

DSN (x1)



AFL (x8)



AIW (x1)



AIX (x4)



AFU (x1)



2

2

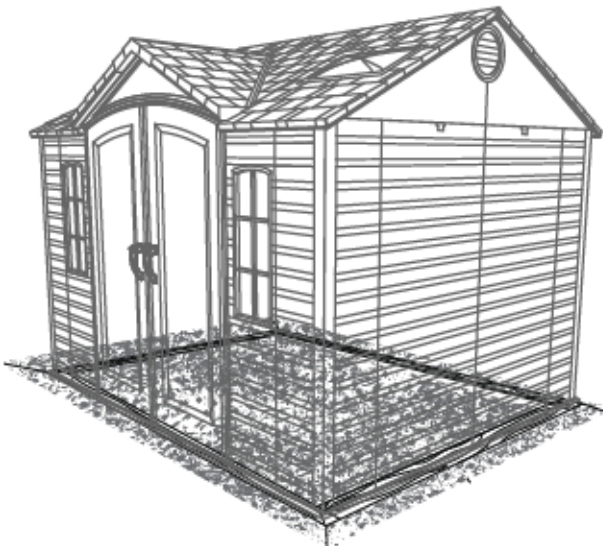
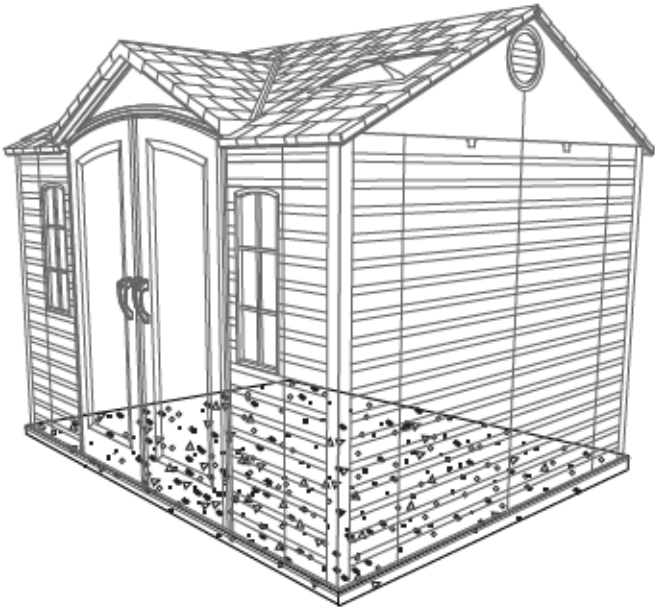



1

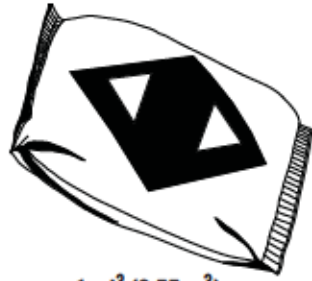

1 yd³ (0,77 m³)

1



1.1

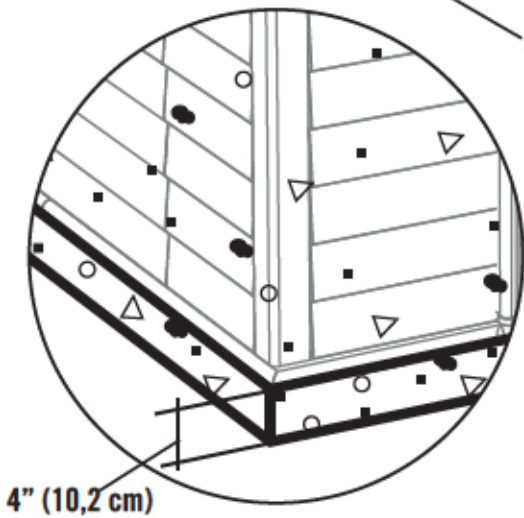
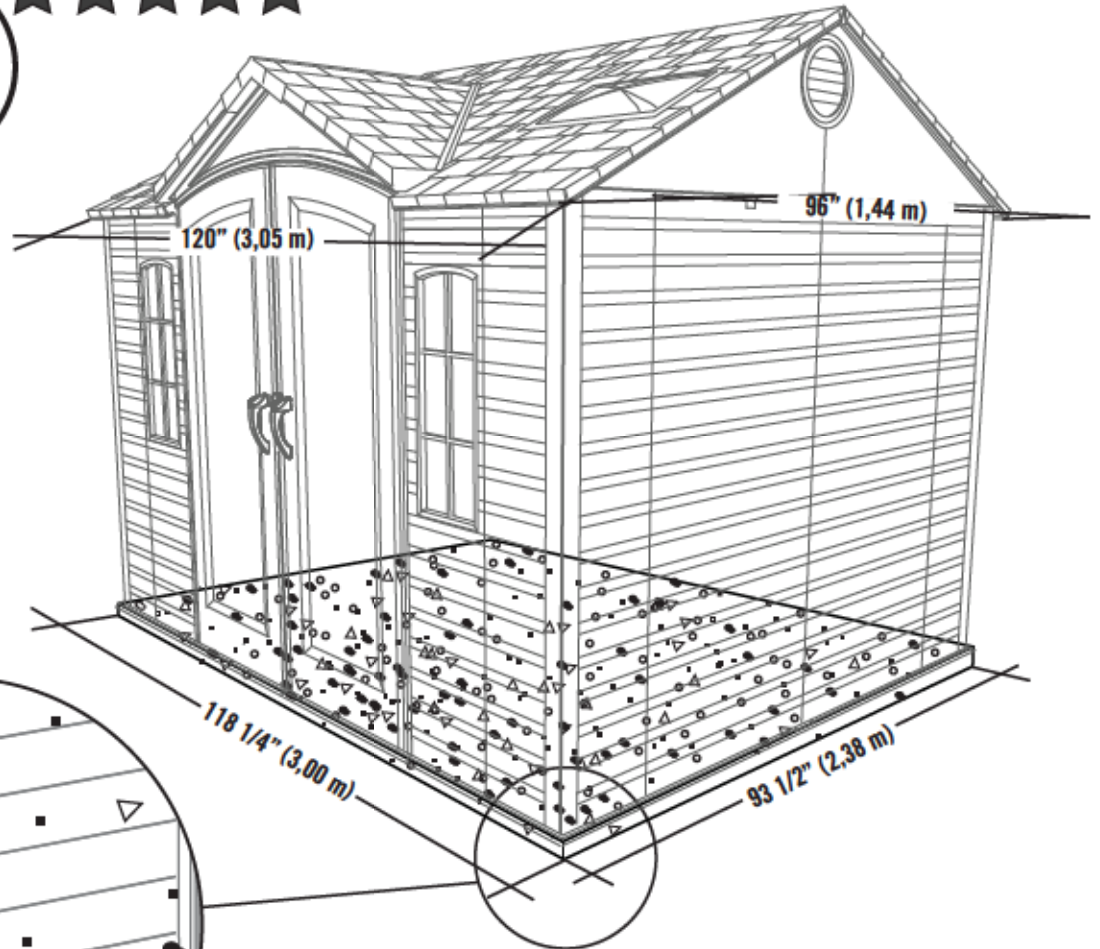



1



1.2

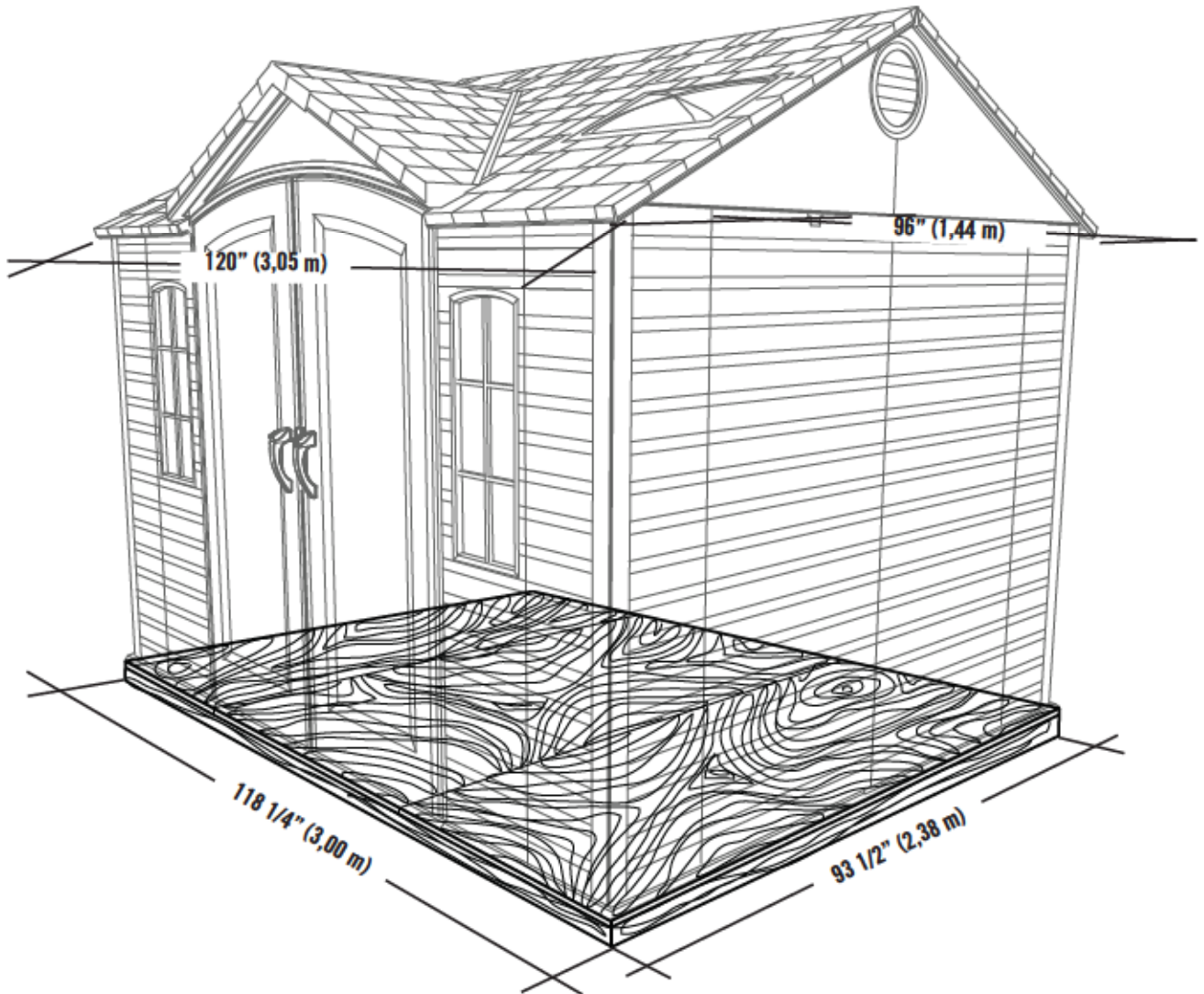



1



2" x 4" x 118 1/4" (5,1 cm x 10,2 cm x 3,00 m) (x2)



2" x 4" x 90 1/2" (5,1 cm x 10,2 cm x 2,30 m) (x9)

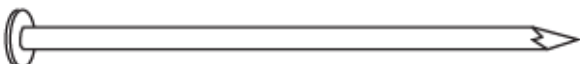

16d 3" (16d x 7,62 cm) (x36)

1.2.1



x8

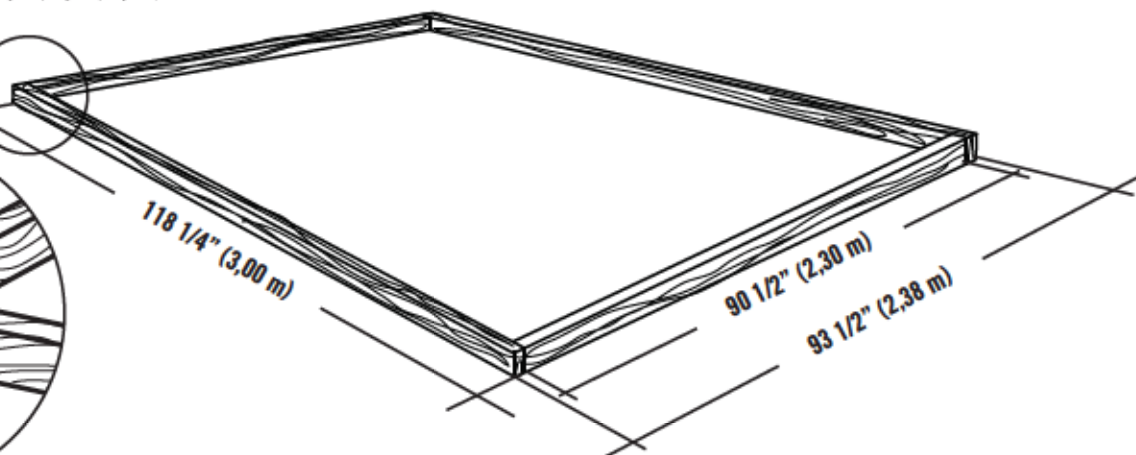
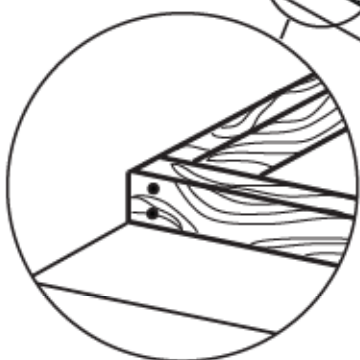

1.2.2



x36

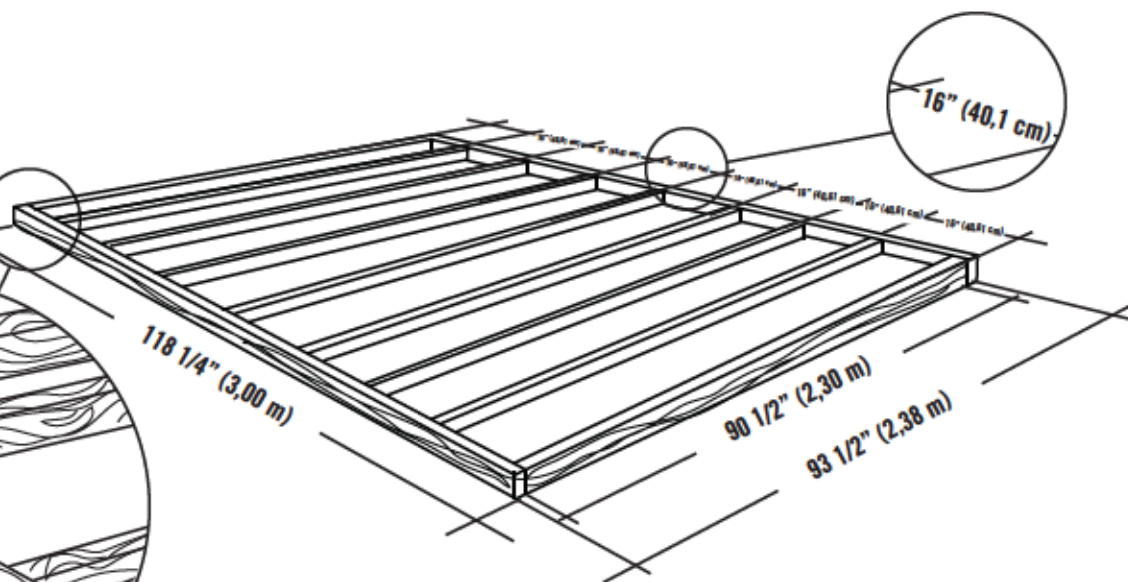
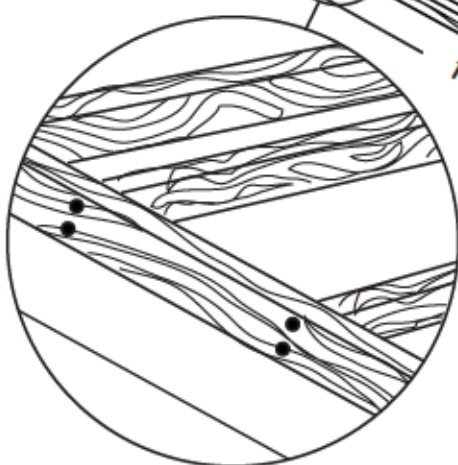



1



48" x 93 1/2" x 3/4"
(1,22 m x 2,38 m x 19,1 mm) (x2)



22 1/4" x 93 1/2" x 3/4"
(10,2 cm x 2,38 m x 19,1 mm) (x1)

8d 1 1/2" (8d 3,81 cm) (x84)



1.2.3

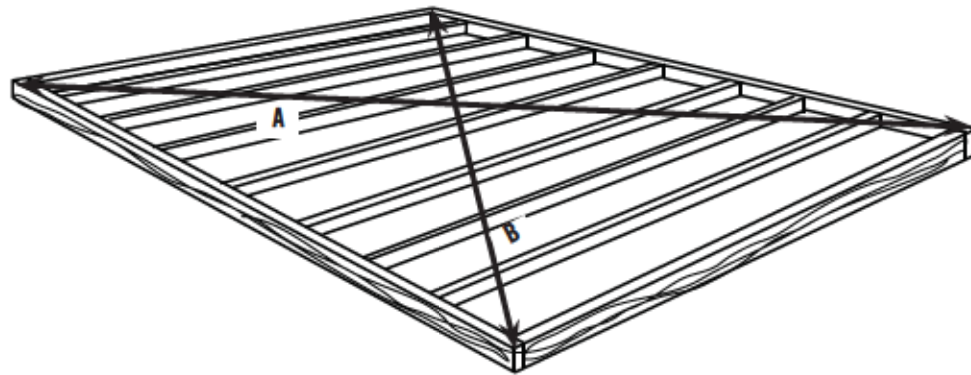

! A = B



1.2.4

- After nailing the panels to the frame, drill drainage holes between the 2x4s as shown.
- Después de clavar los paneles al bastidor, taladre unos agujeros para desagüe entre los montantes como se muestra.
- Après avoir cloué les panneaux à la charpente, percez quelques trous de drainage entre les montants comme illustré.

x84

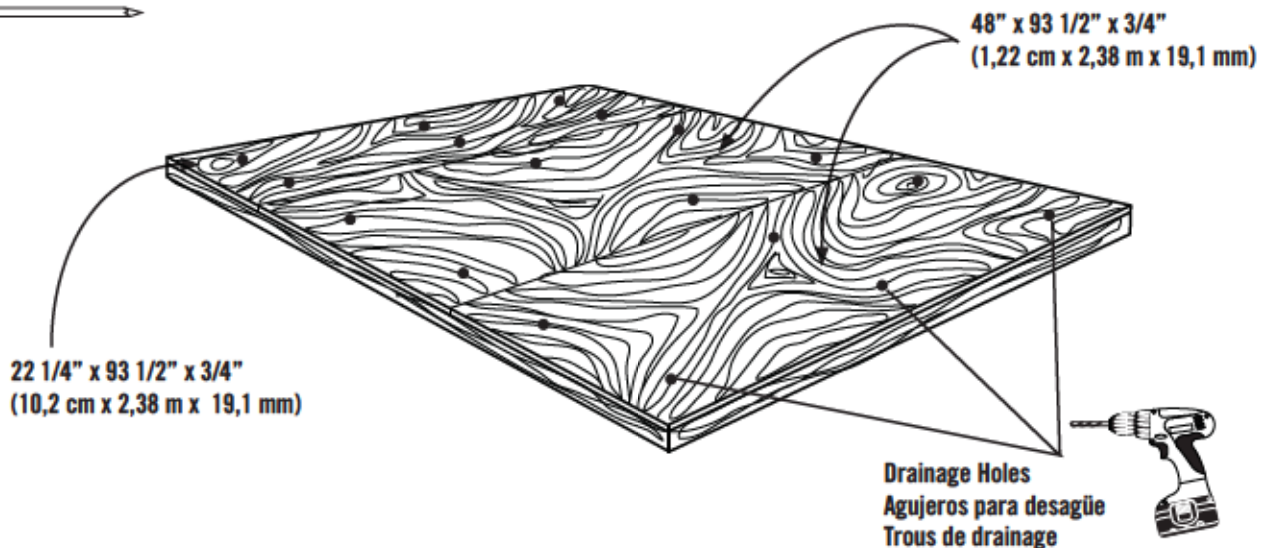

x18!



1



.37 yd³ (0,29 m³)



1.3

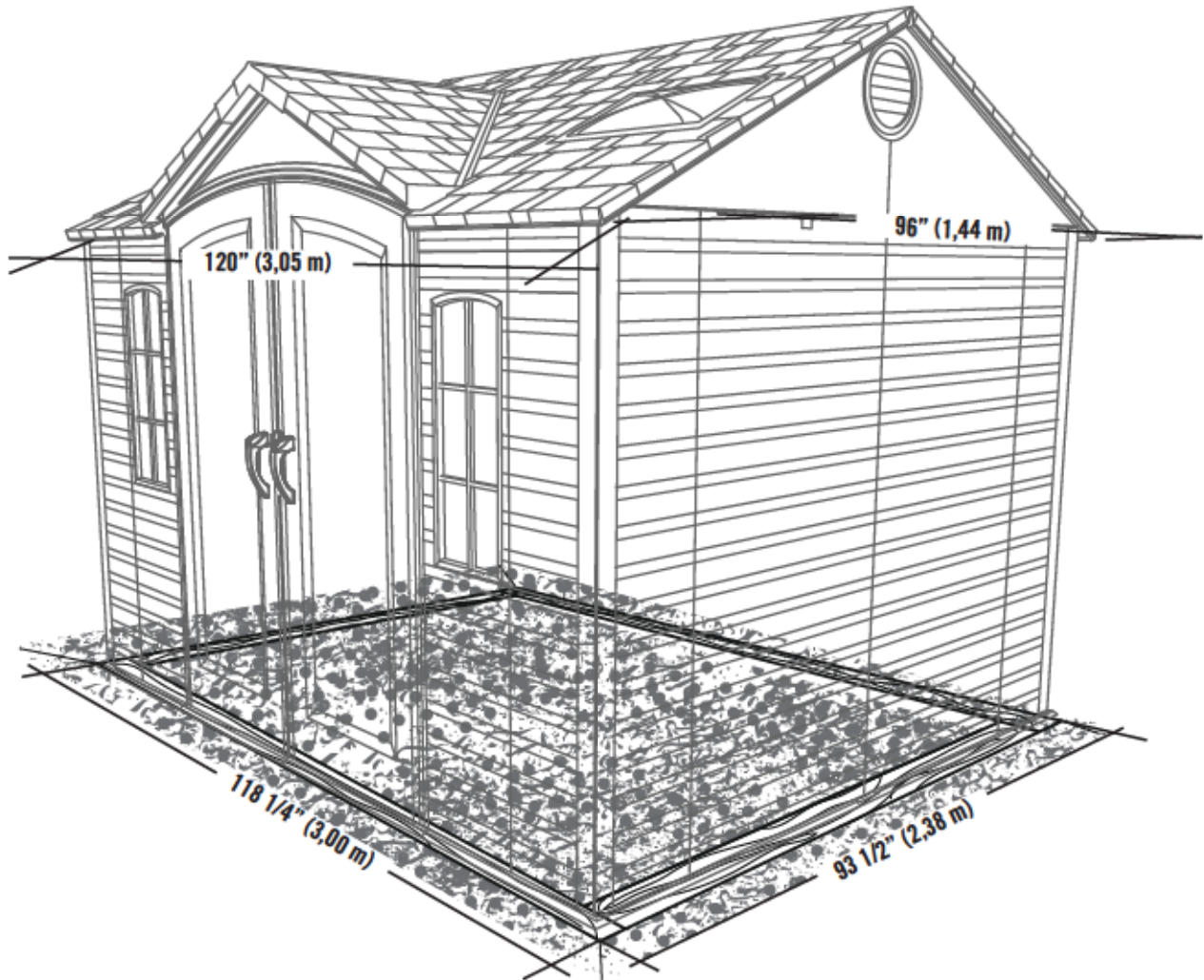



1



2" x 4" x 118 1/4" (5,1 cm x 10,2 cm x 3,00 m) (x2)



2" x 6" x 90 1/2" (5,1 cm x 15,2 cm x 2,30 m) (x2)



8d 1 1/2" (8d 3,81 cm) (x16)



(x4)



1.3.1

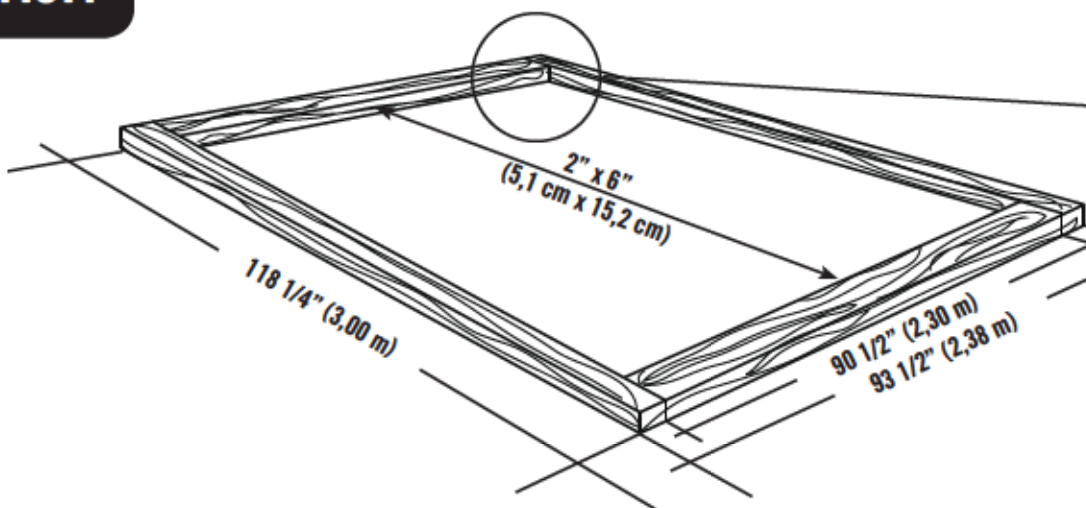

! x4

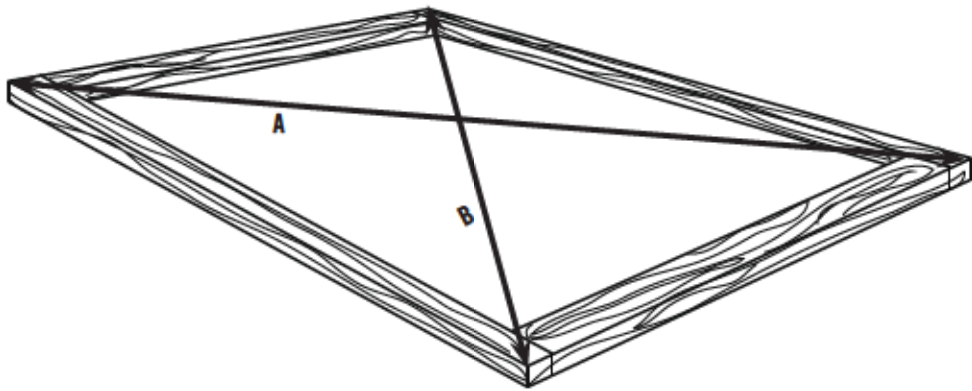

! A = B



x16





1



.37 yd³ (0,29 m³)



1.3.2

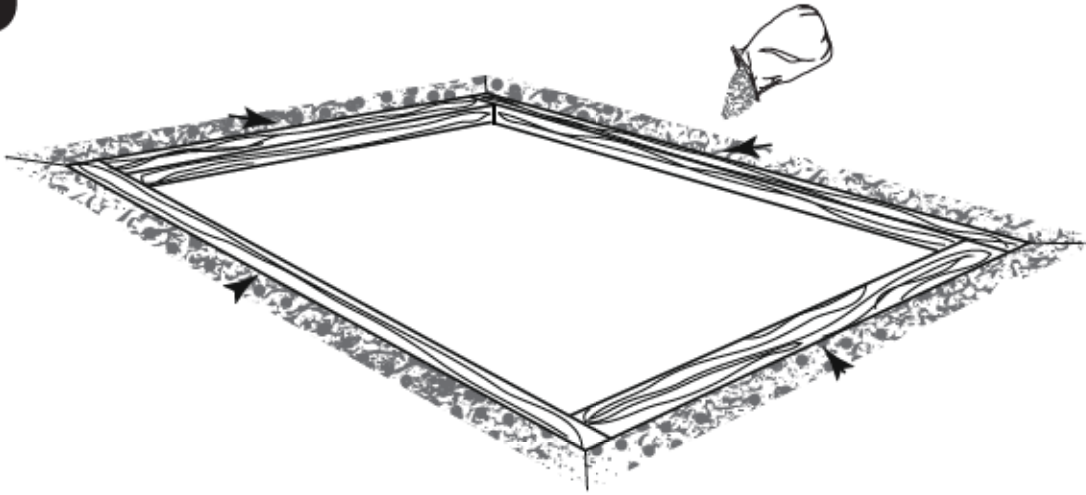

1.3.3

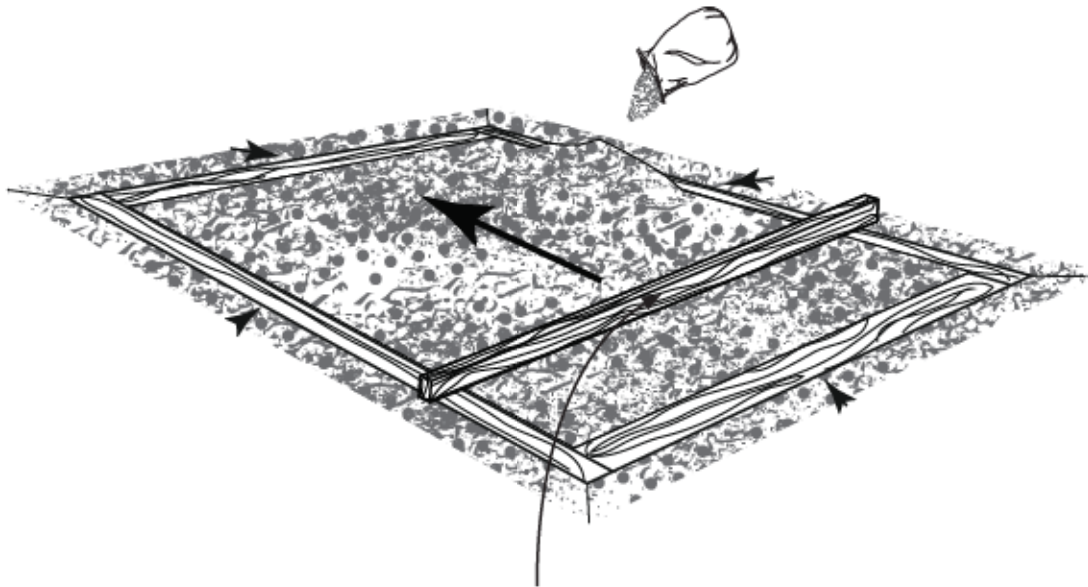

2" x 4" x 8' (5,1 cm x 10,2 cm x 2,44 m) (x1)



2



AHO (x2)

ADC (x1)

BQC (x20)



*Note: These are not anchoring screws. Their purpose is to fasten together the Floor Panels.
Nota: Estos no son Tornillos de anclaje. Son propósito es sólo para unir los Paneles de piso.
Note : Ces Vis ne sont pas de vis d'ancrage. Leur but est pour attacher les Panneaux de plancher.*



2

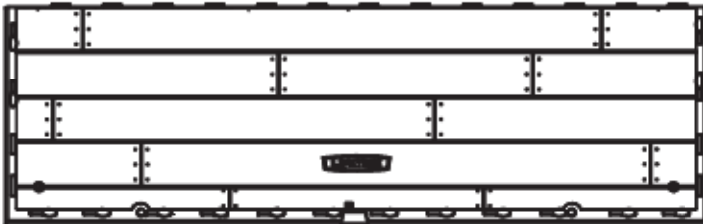

CUW (x2)



CUD (x2)

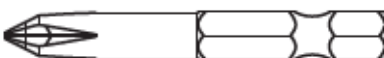

ADC (x1)



2



2.1

- The tabs of the **Floor Panels (CUW and CUD)** interlock.
- Las lengüetas de los **Paneles de piso (CUW y CUD)** se encastran entre sí.
- Les **Panneaux de plancher (CUW et CUD)** ont des languettes à emboîtement.

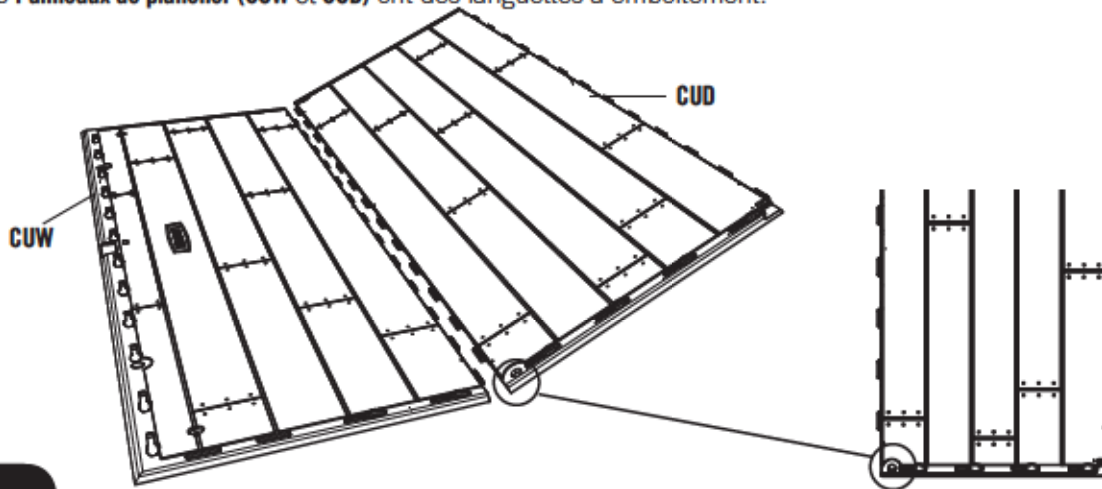
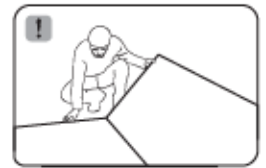

2.2

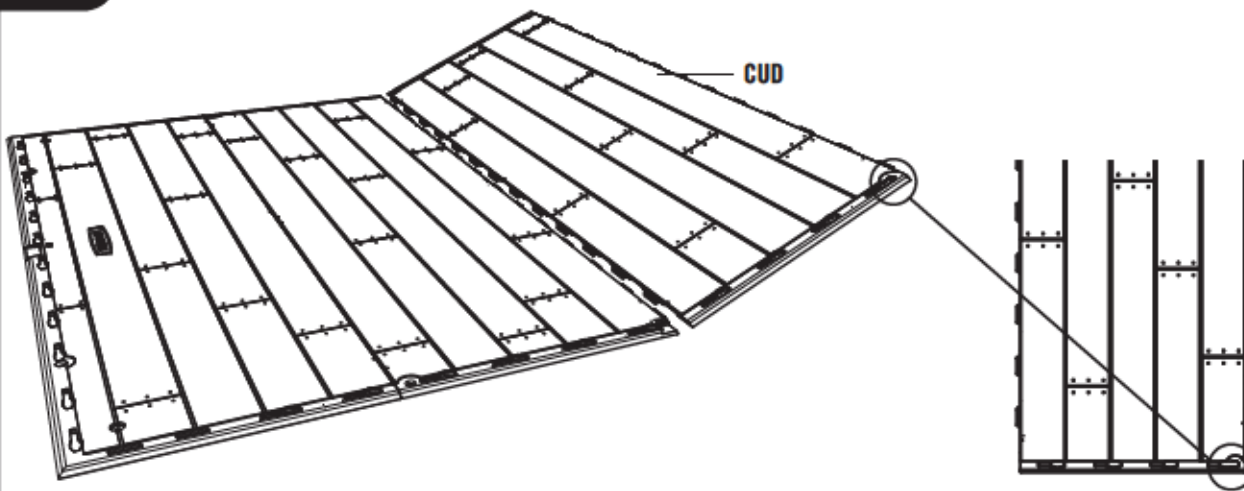



2



AHO (x2)



2.3

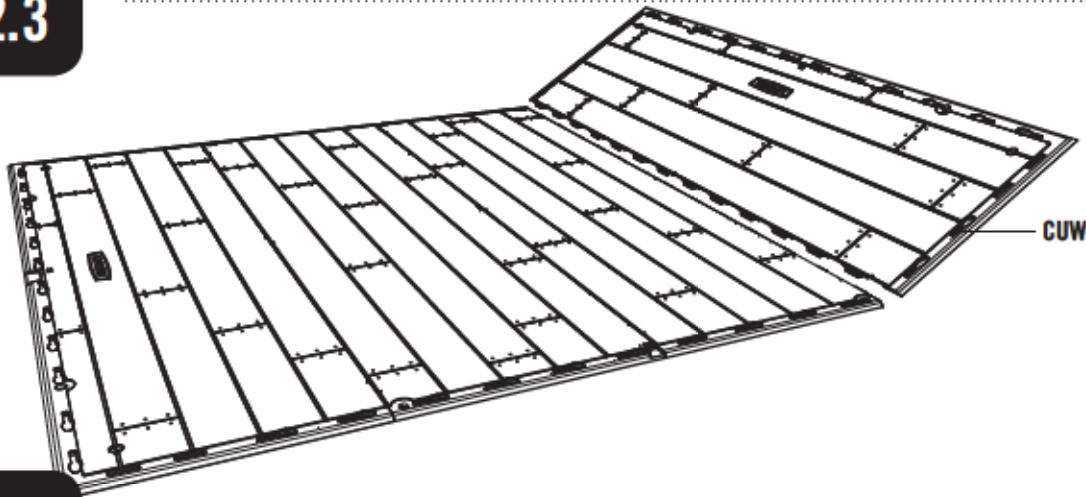

2.4

- The slit in the **Bushings (AHO)** should face the front of the shed. The Doors will be installed here later.
- La rendija en los **Casquillos (AHO)** debe dar hacia el borde delantero del cobertizo. Se instalarán las Puertas aquí más tarde.
- La fente dans les **Bagues (AHO)** doit donner sur le bord avant de l'abri. Vous installerez les Portes ici plus tard.

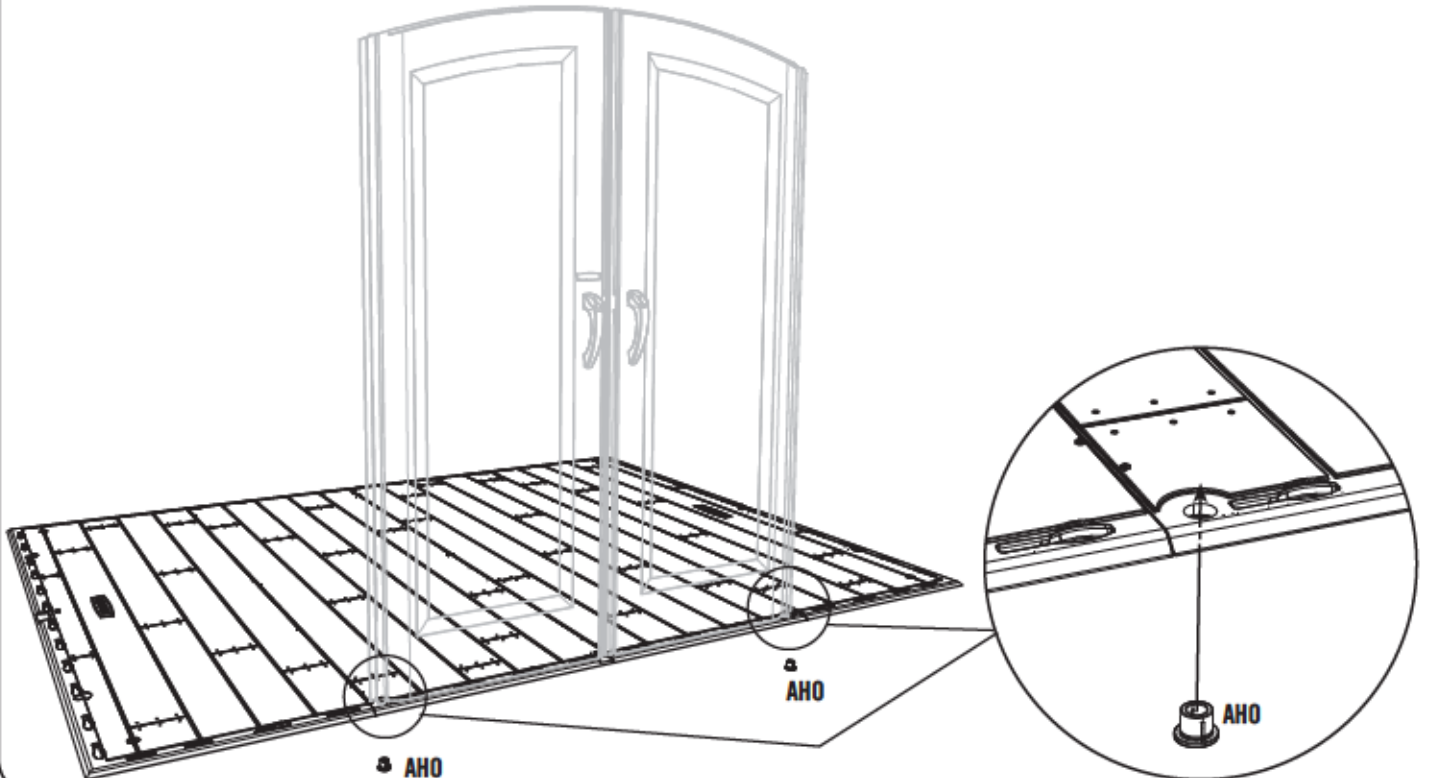



2



BQC (x18/20)



2.5

• Insert the **Screws (BQC)** (six (6) per seam) through the divots in the Floor Panels and into the tabs of the adjacent Floor Panels. (The divots are near the seams of the Floor Panels.)

• Introduzca los **Tornillos (BQC)** (seis (6) por cada junta) a través de las marcas en los Paneles de piso y dentro de las lengüetas de los Paneles de piso adyacentes. (Se encuentran las marcas cerca de las juntas de los Paneles de piso.)

• Insérez les **Vis (BQC)** (six (6) par chaque jonction) à travers les marques dans les Panneaux de plancher et dans les languettes du Panneaux de plancher contigu. (Les marques se trouvent près des jonctions des Panneaux de plancher.)



BQC

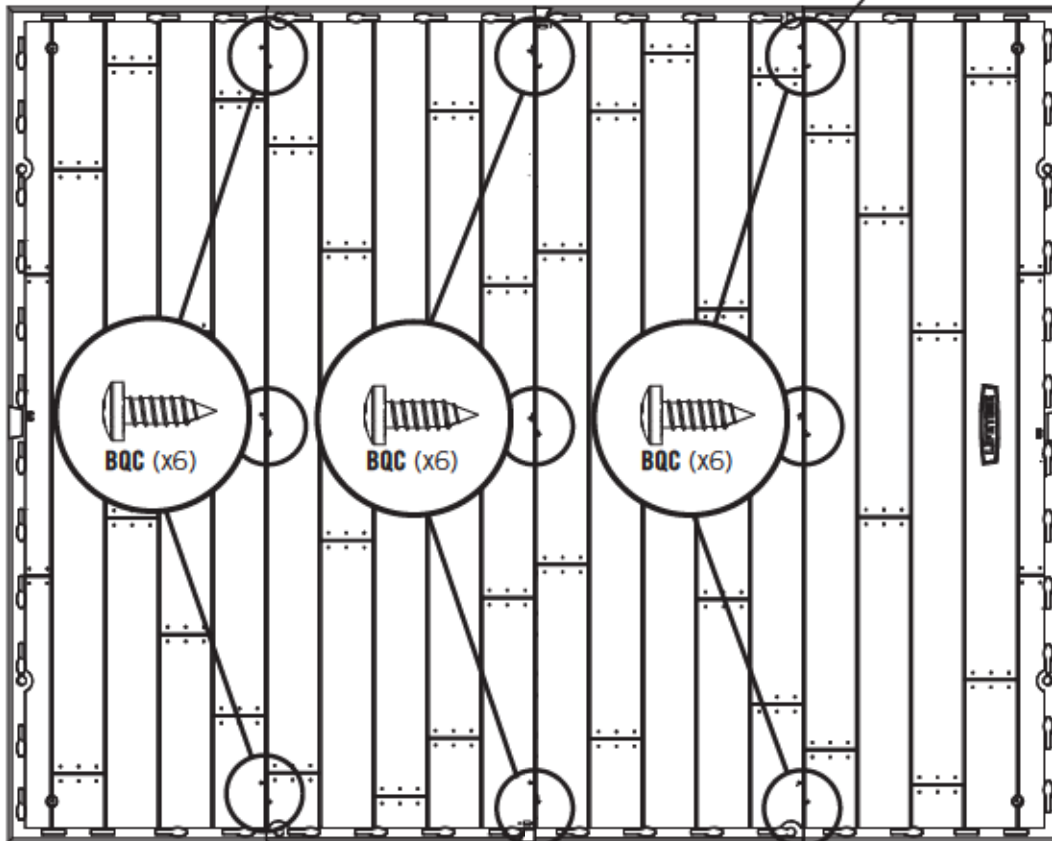
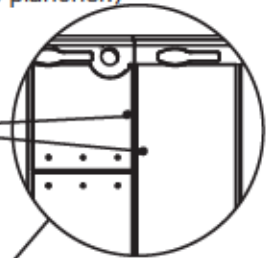

3



DTK (x14)

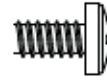

ADY (x11)



ADJ (6)



DTJ (x1)



AHT (x1)



ADK (x24)



CXK (x2)

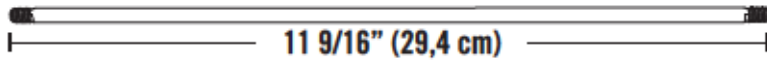

ADH (x3)

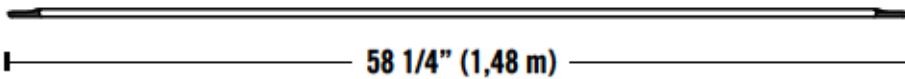

DSP (x1)

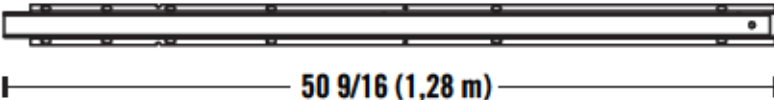

DSQ (x2)

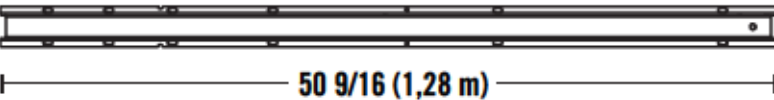

DSR (x3)

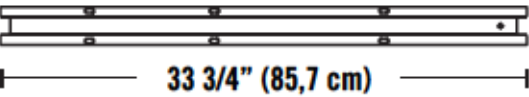

DSO (x1)



AFG (x3)



AIP (x3)

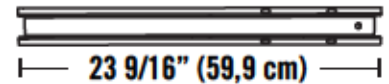

DSM (x1)

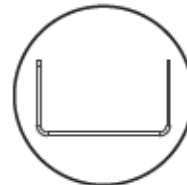

DSN (x1)

DSN (x1)



7/16" (11 mm) (x2)



3/8" (10 mm) (x2)





3

3/8" (x2)
(10 mm) (x2)



DTK (x8)



ADK (x8)

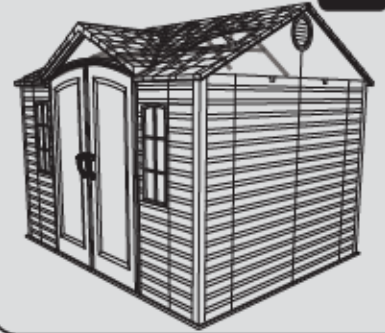

3.1

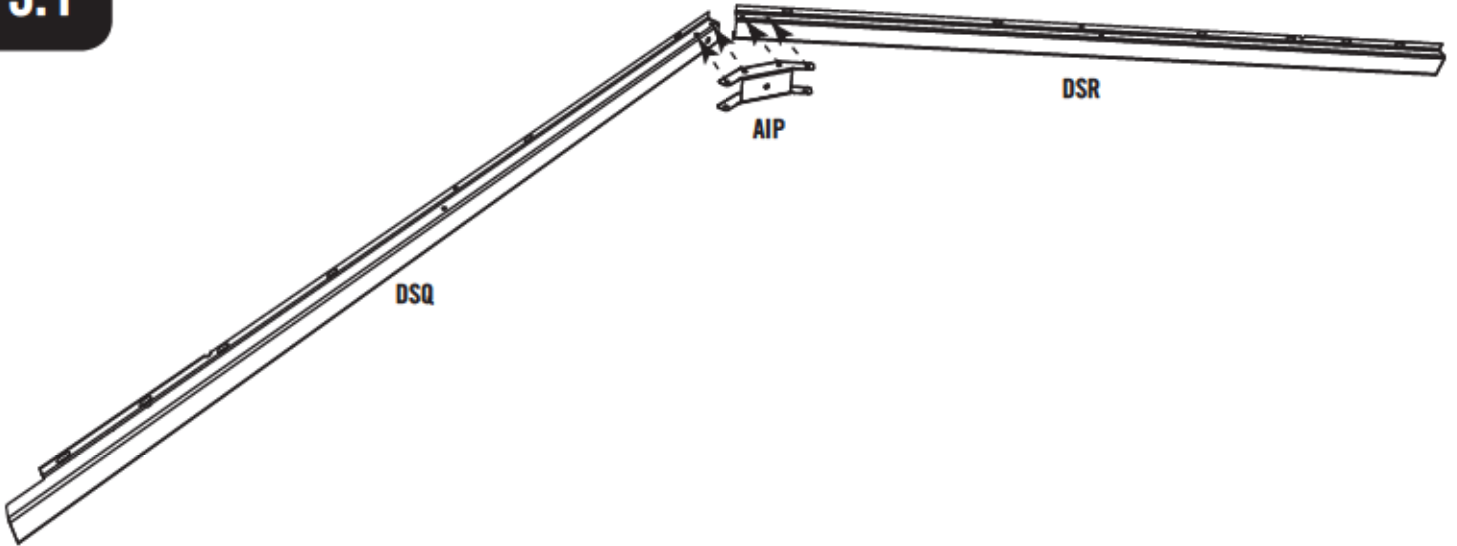

3.2

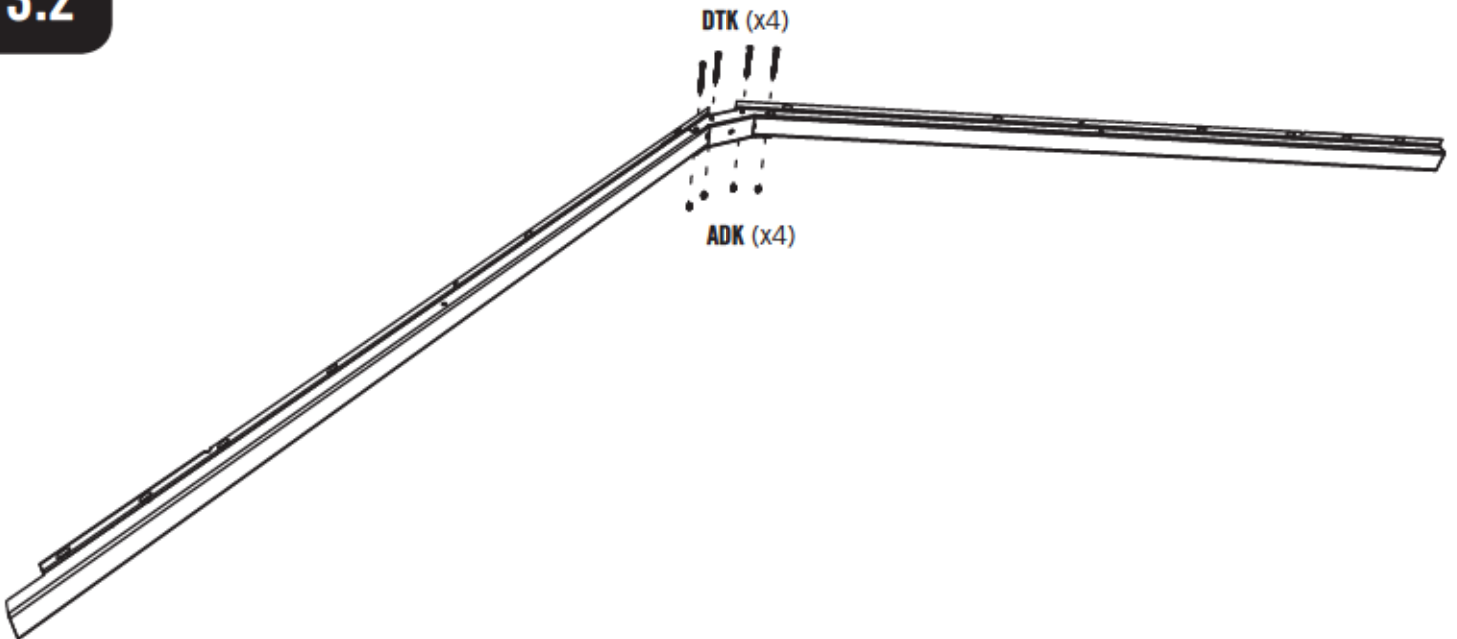



3



3/8"
(10 mm)

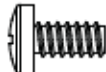

ADY (x8)



ADK (x8)



3.3

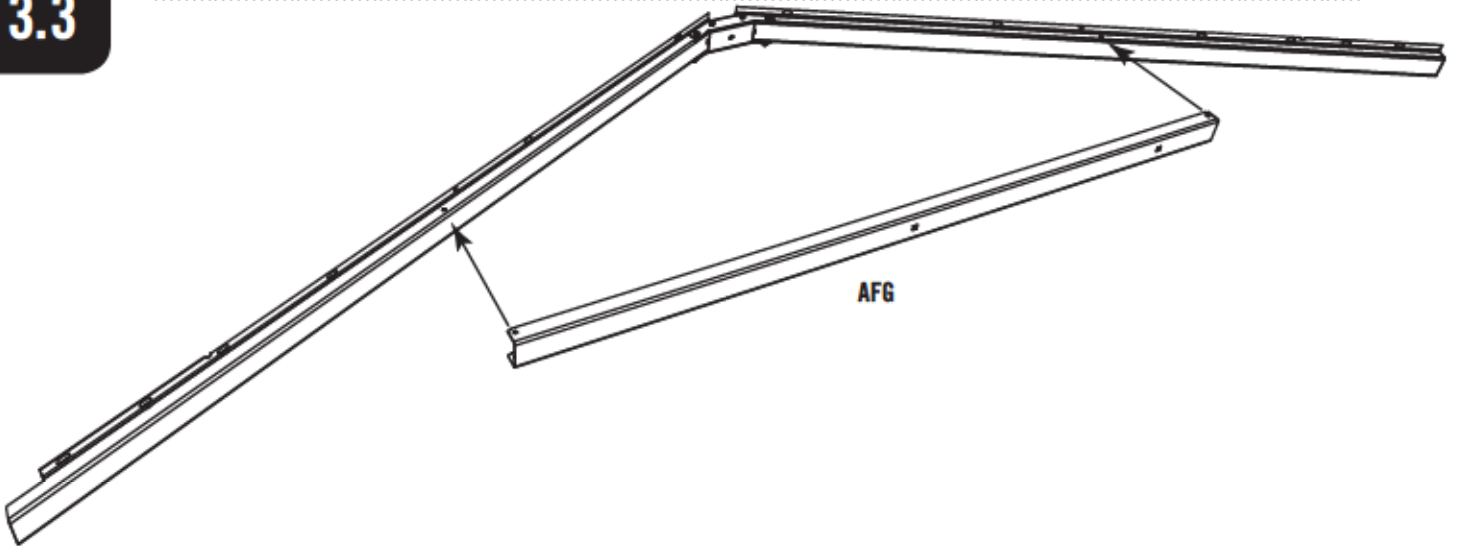

3.4

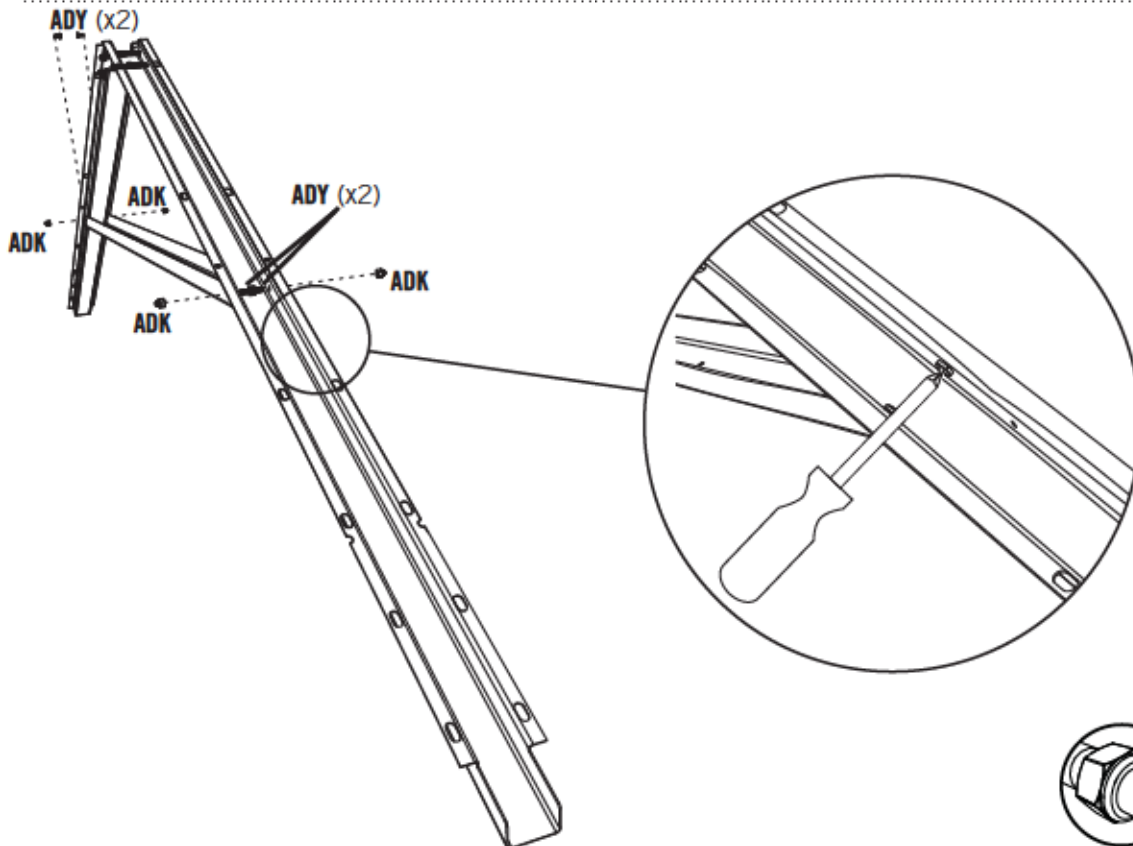



3

7/16" (x2)
(11 mm) (x2)



ADJ (x4)

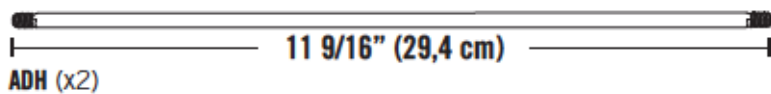

ADH (x2)



3.5

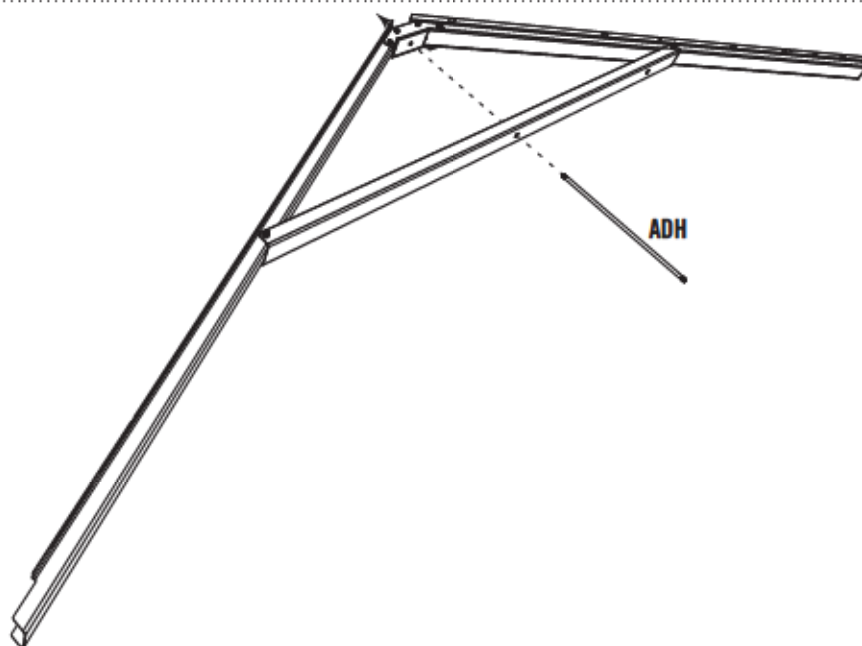

3.6

- This notched end will face the front of the Shed.
- Este extremo muescado dará a la parte delantera del Cobertizo.
- Cette extrémité encochée fera face à la partie avant de l'Abri.

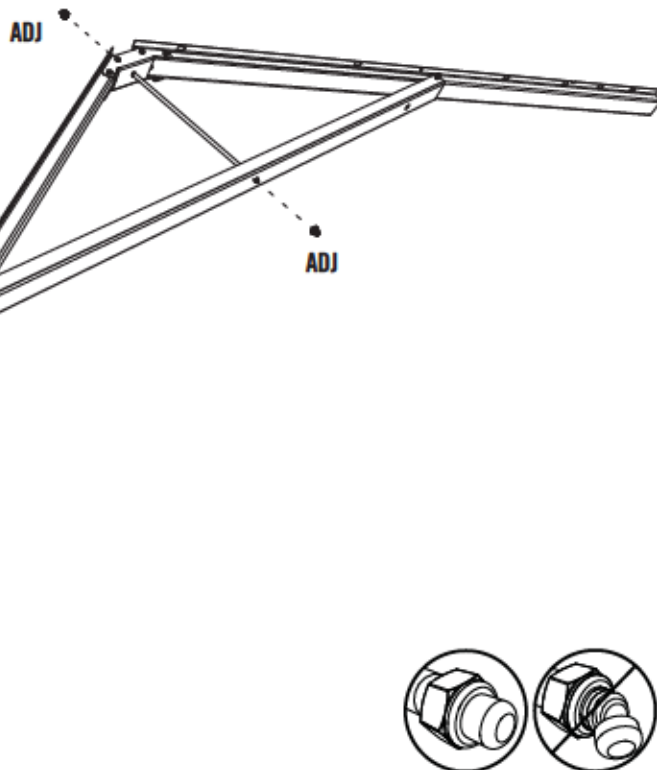

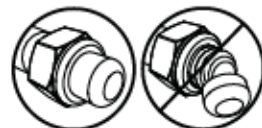

3.1 - 3.6 x2!





3

3/8" (x2)
(10 mm) (x2)





DTK (x4)

ADK (x4)

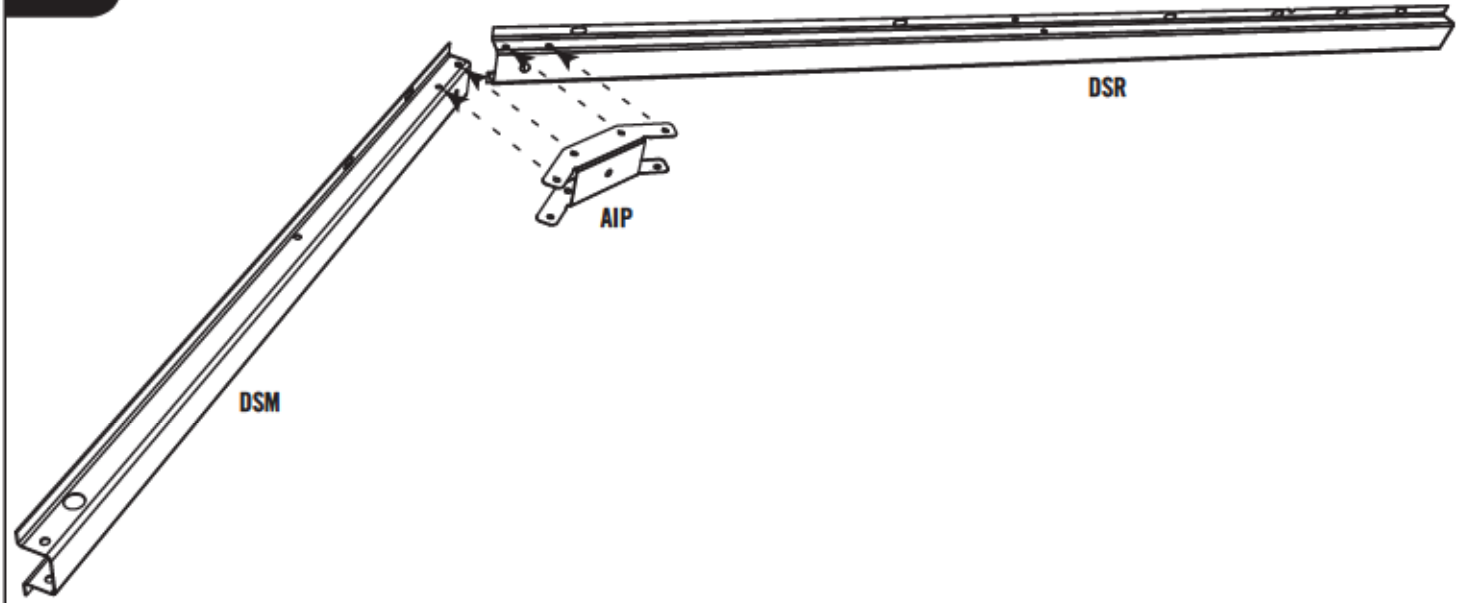

3.7



3.8

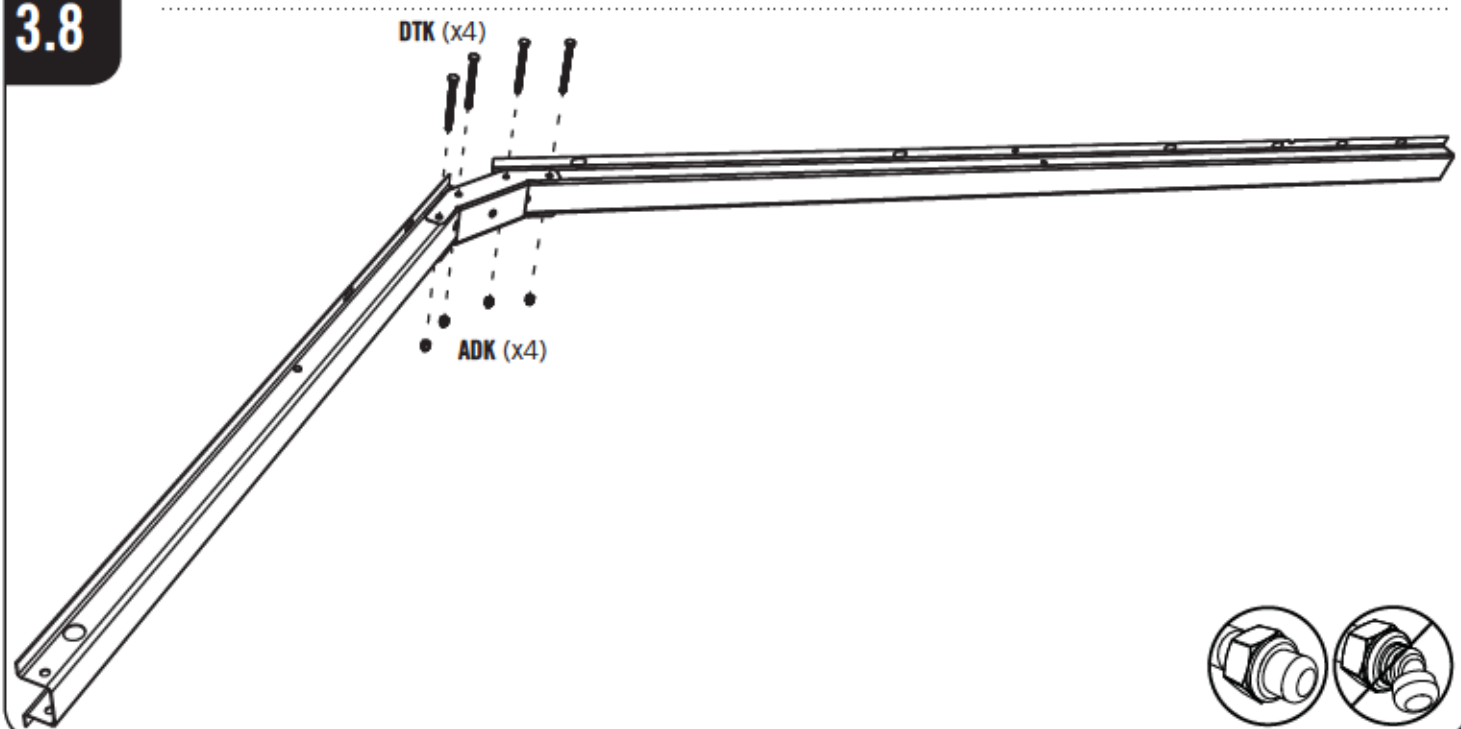



3



3/8"
(10 mm)

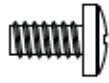

ADY (x2)



ADK (x2)



3.9

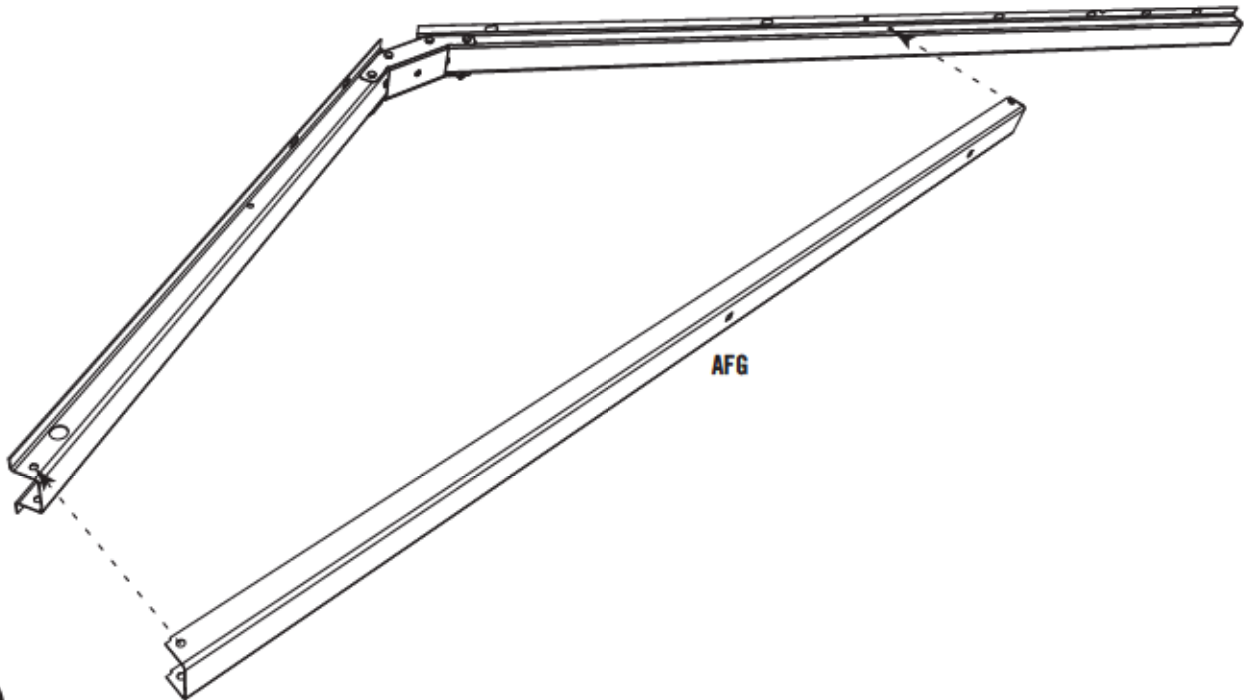

3.10

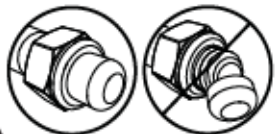
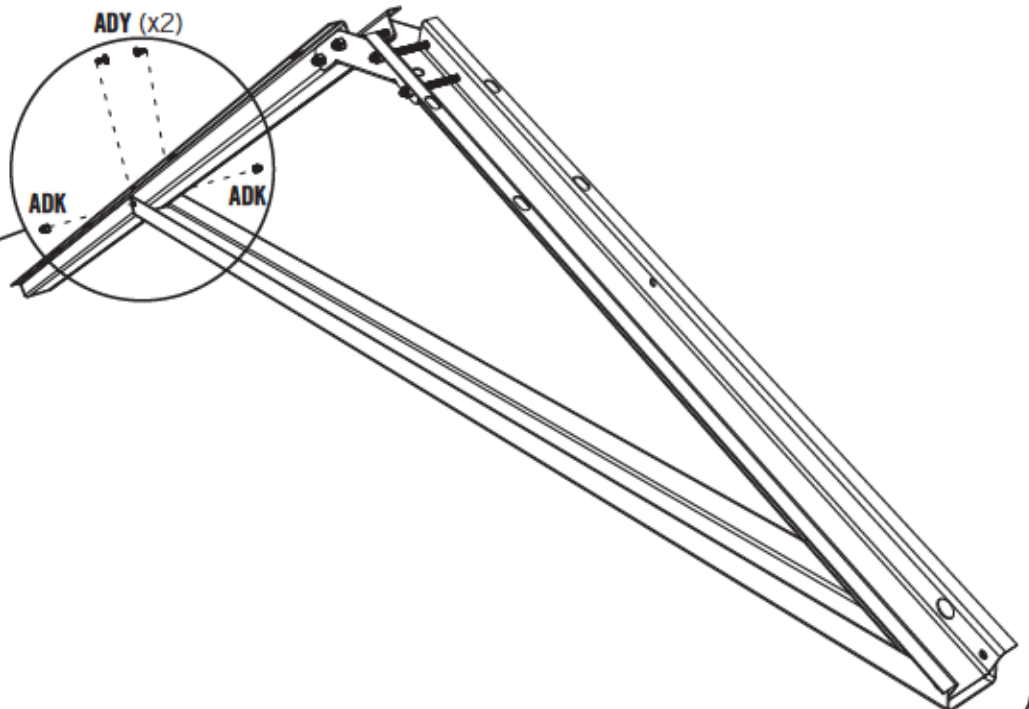
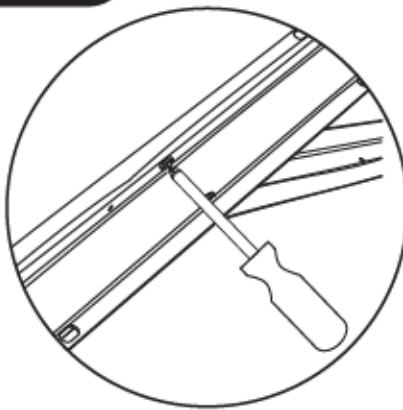

**3**

3/8" (x2)
(10 mm) (x2)

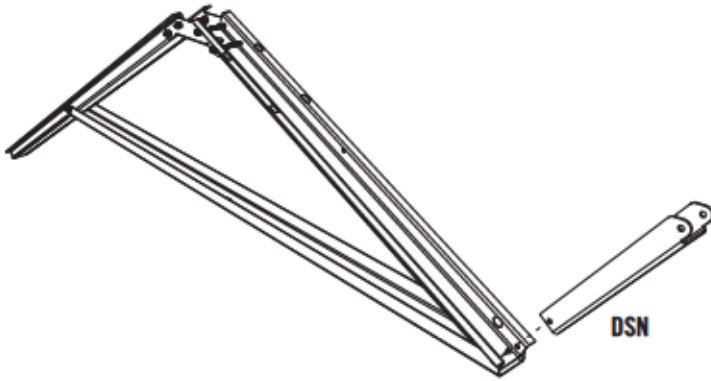
**DTK** (x2)**ADK** (x1)**DTJ** (x1)**CXK** (x2)**3.11****3.12**

- Only finger tighten this **Nut (ADK)** for now.
- Apriete la **Tuerca (ADK)** a mano por el momento.
- Serrez l'**Écrou (ADK)** à la main pour le moment.

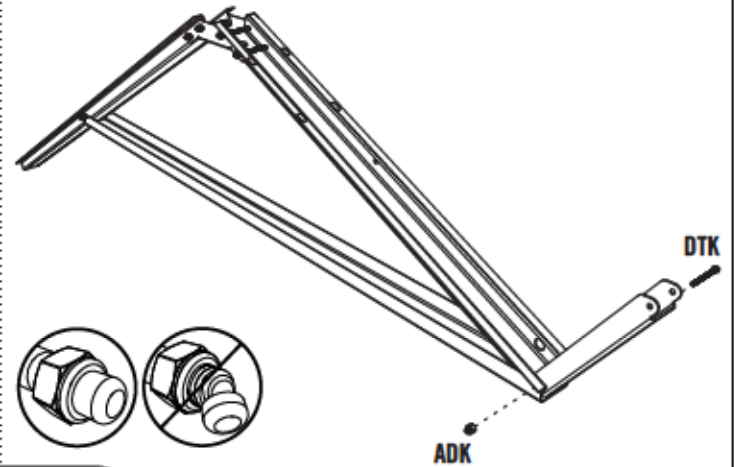
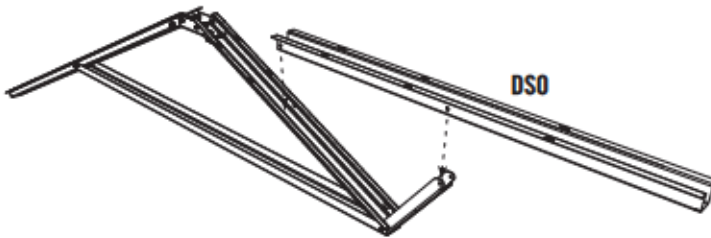
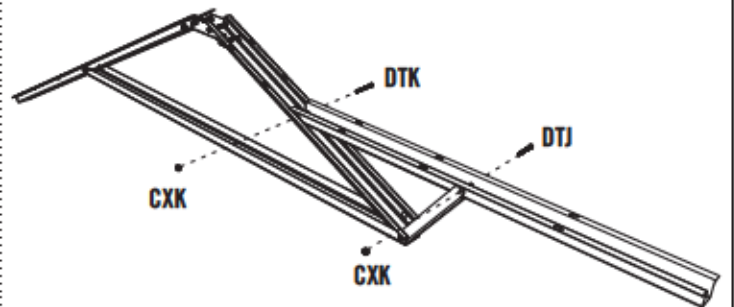
**3.13****3.14**



3

7/16" (x2)
(11 mm) (x2)



ADJ (x2)

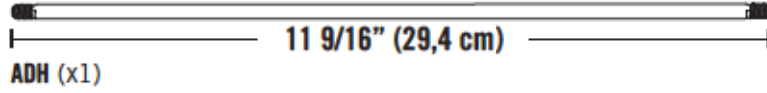

ADH (x1)



3.15

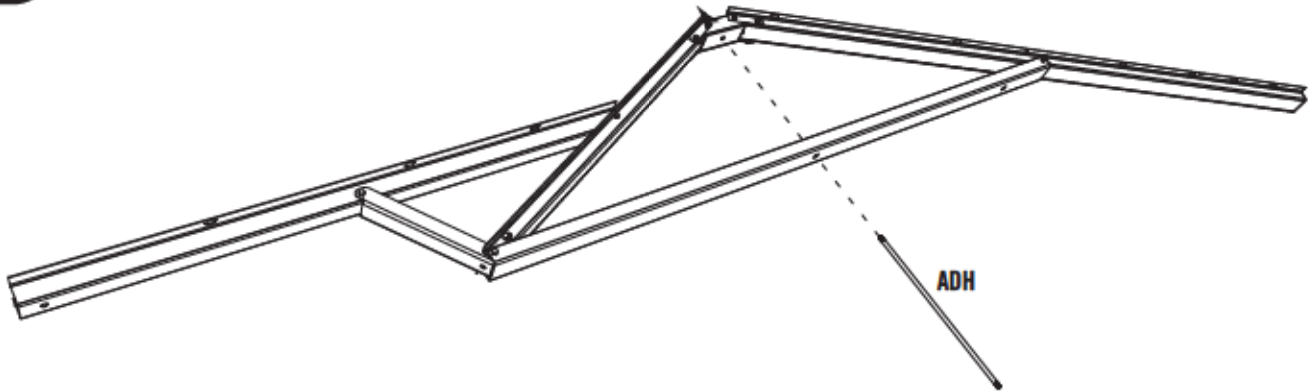

3.16

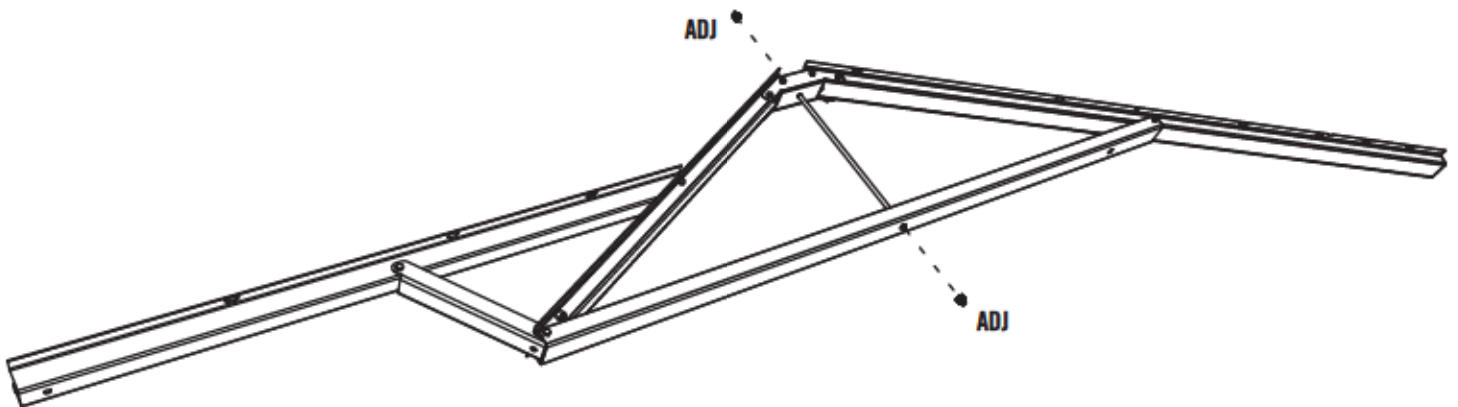
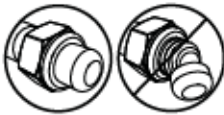



3



3/8" (x2)
(10 mm) (x2)



AHT (x1)

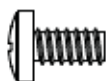

ADY (x1)



ADK (x1)



3.17

- Only tighten the **Nut (ADK)** by hand in this step.
- Sólo apriete la **Tuerca (ADK)** à mano en este paso.
- Ne serrez l'**Écrou (ADK)** qu'à la main dans cette étape.

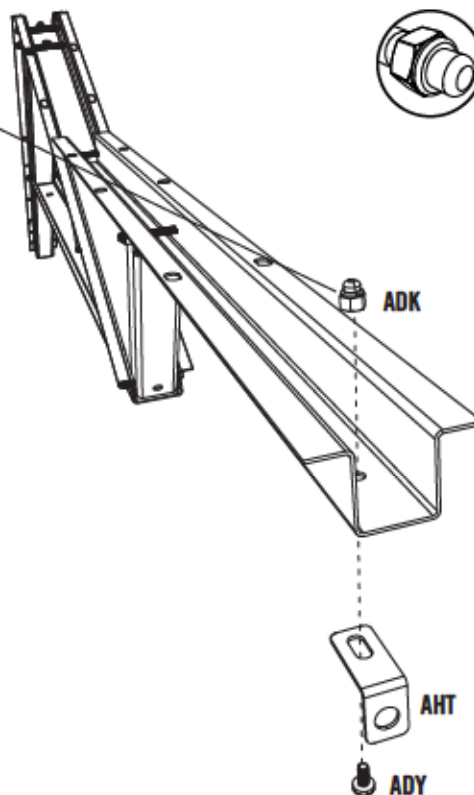

3.18

- This end will face the front of the Shed.
- Este extremo dará a la parte delantera del Cobertizo.
- Cette extrémité fera face à la partie avant de l'Abri.

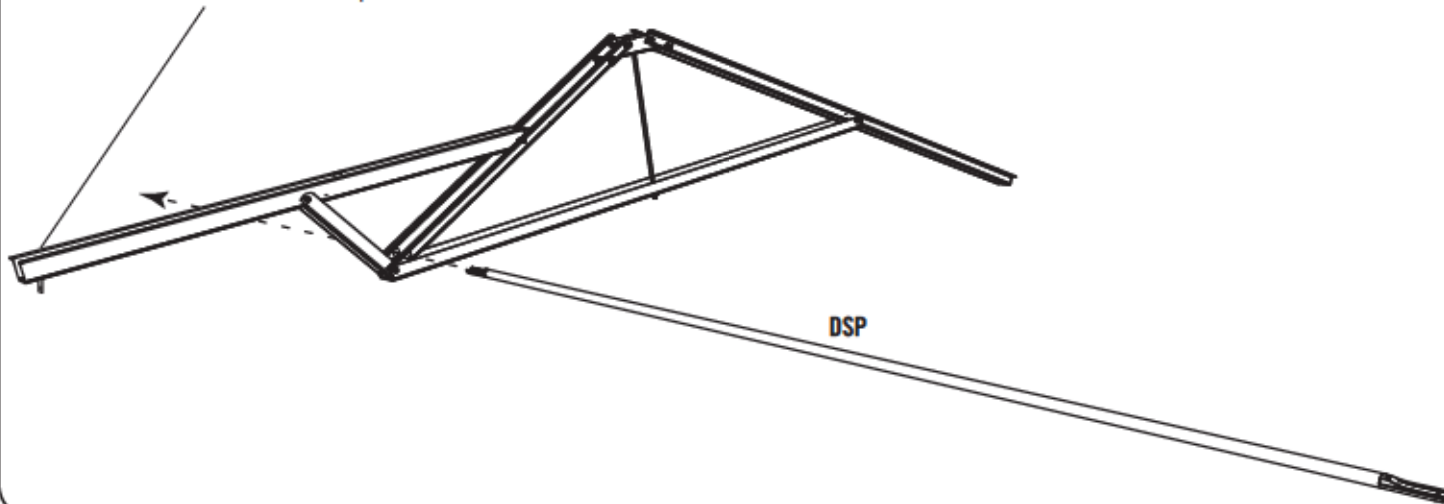

4

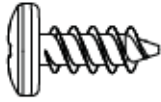

ADZ (x85)



Metal Pieces / Piezas de metal / Pièces en métal

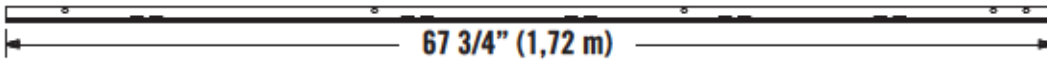

AFM (x4)

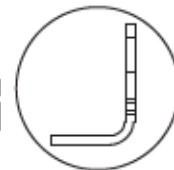

Plastic Pieces / Piezas de plástico / Pièces en plastique

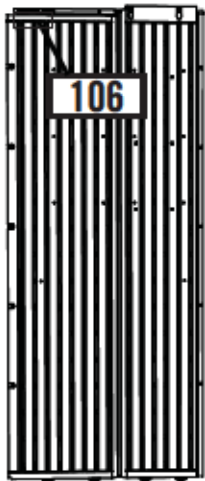

AGW (x2)

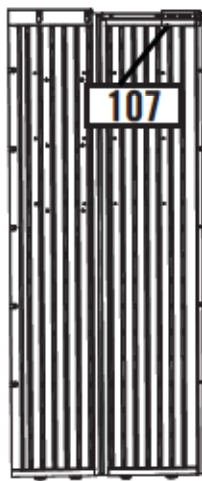

AGL (x2)



AHD (x6)



AHH (x1)



BDI (x1)

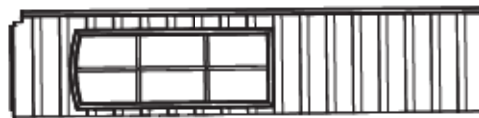

BDH (x1)



AIW (x1)





4



AIW (x1)



4.1

• Insert tabs at the bottom of the **Right Half-Wall Panel (BDI)** into the third and fourth slots from the front, right corner of the Floor.

• Introduzca las lengüetas al borde inferior del **Panel angular (BDI)** en las tercera y cuarta ranuras de la esquina derecha del Piso.

• Insérez les languettes au bord inférieur du **Panneau angulaire (BDI)** dans les troisième et quatrième rainures du coin droit du Plancher.

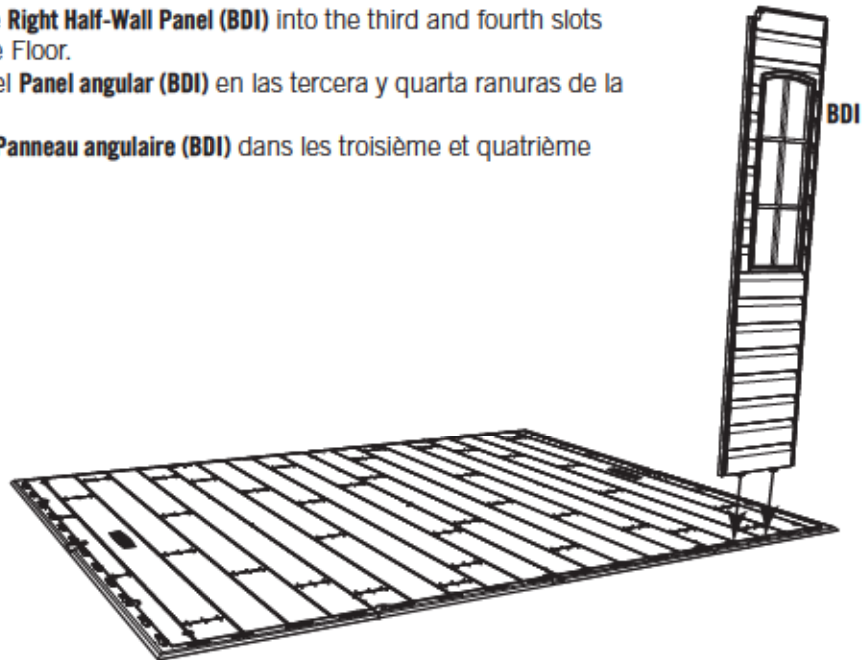

4.2

• Slide the Panel to the left.

• Deslice el Panel a la izquierda.

• Faites glisser le Panneau à gauche.

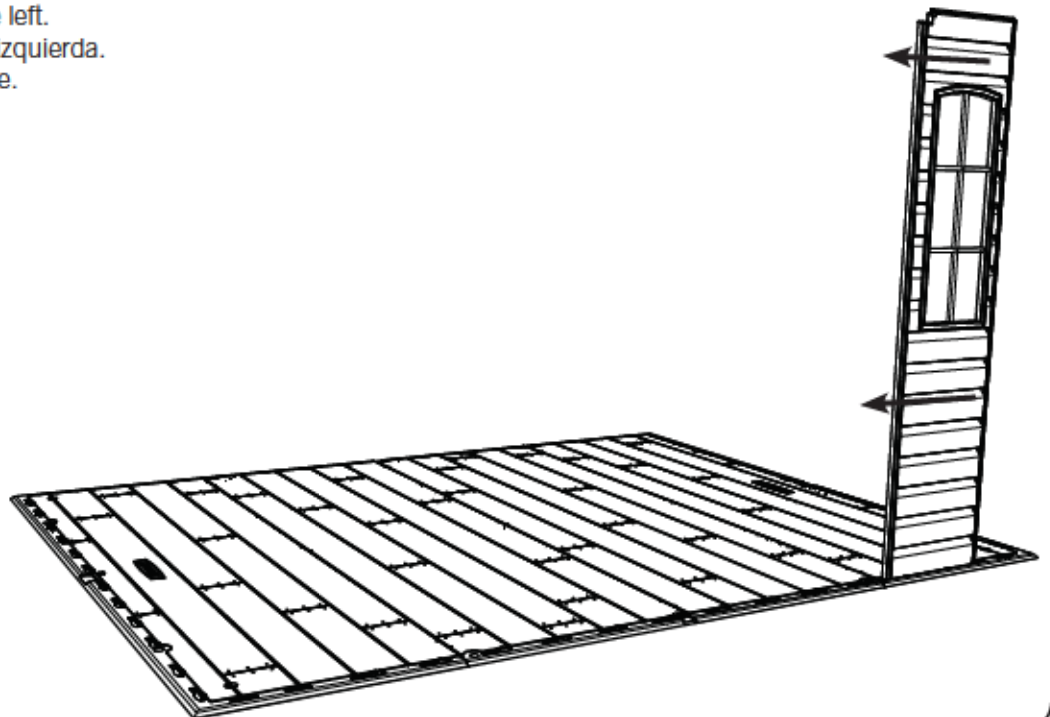

**4****AIW (x1)**

4.3

• Insert tabs at the bottom of the **Corner Panel (AGW)** into the first two slots along the right edge of the Floor, and slide the Panel toward the front of the Floor.

- Introduzca las lengüetas al borde inferior del **Panel angular (AGW)** en las primeras dos ranuras a lo largo del borde derecho del Piso, y deslice el Panel hacia la parte delantera del Cobertizo.
- Insérez les languettes au bord inférieur du **Panneau angulaire (AGW)** dans les premières rainures le long du bord droit du Plancher, et faites glisser le Panneau vers la partie avant de l'Abri.

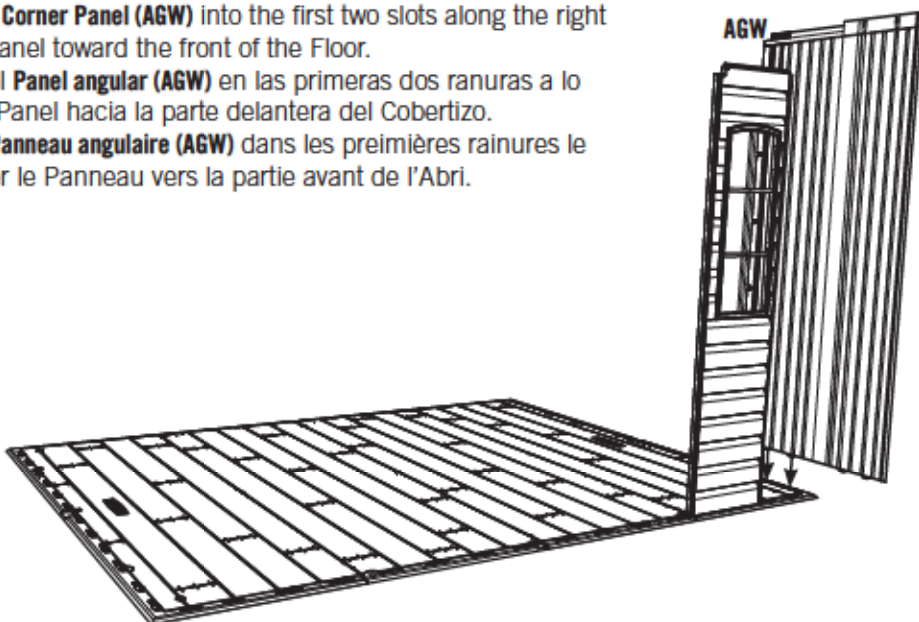

4.4

• Bend the Corner Panel as shown, and pull down to snap the tabs into the first two slots from the right corner of the Floor. Place the **Wood Block (AIW)** underneath the Floor and directly underneath the tab being inserted to help with insertion.

- Despliegue el Panel angular como se muestra, tire para abajo el Panel, e introduzca las lengüetas en las dos primeras muescas de la esquina delantera derecha. Para ayudar con la inserción, coloque el **Bloque de madera (AIW)** debajo el Piso y directamente debajo la lengüeta que quiere insertar.
- Pliez le Panneau angulaire comme illustré, tirez le Panneau vers le bas, et insérez les languettes dans les premières deux encoches du coin vant droit. Pour aider avec l'insertion, mettez le **Bloc en bois (AIW)** sous le Plancher et directement sous l'onglet que vous voulez insérer.

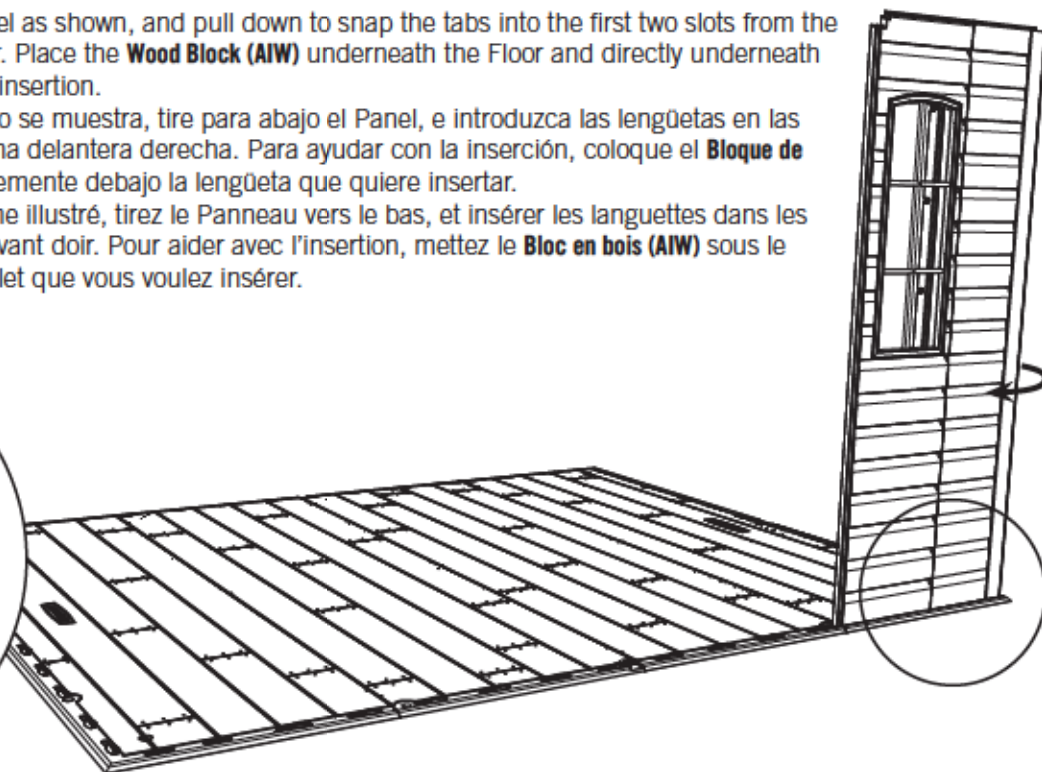



4



AIW (x1)



ADZ (x15)



4.5

- Secure the two Panels using five (5) Screws (ADZ).
- Sujete los dos Paneles usando cinco (5) Tornillos (ADZ).
- Attachez bien les deux Panneaux à l'aide de cinq (5) Vis (ADZ).

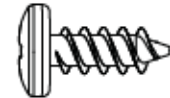

ADZ (x5)

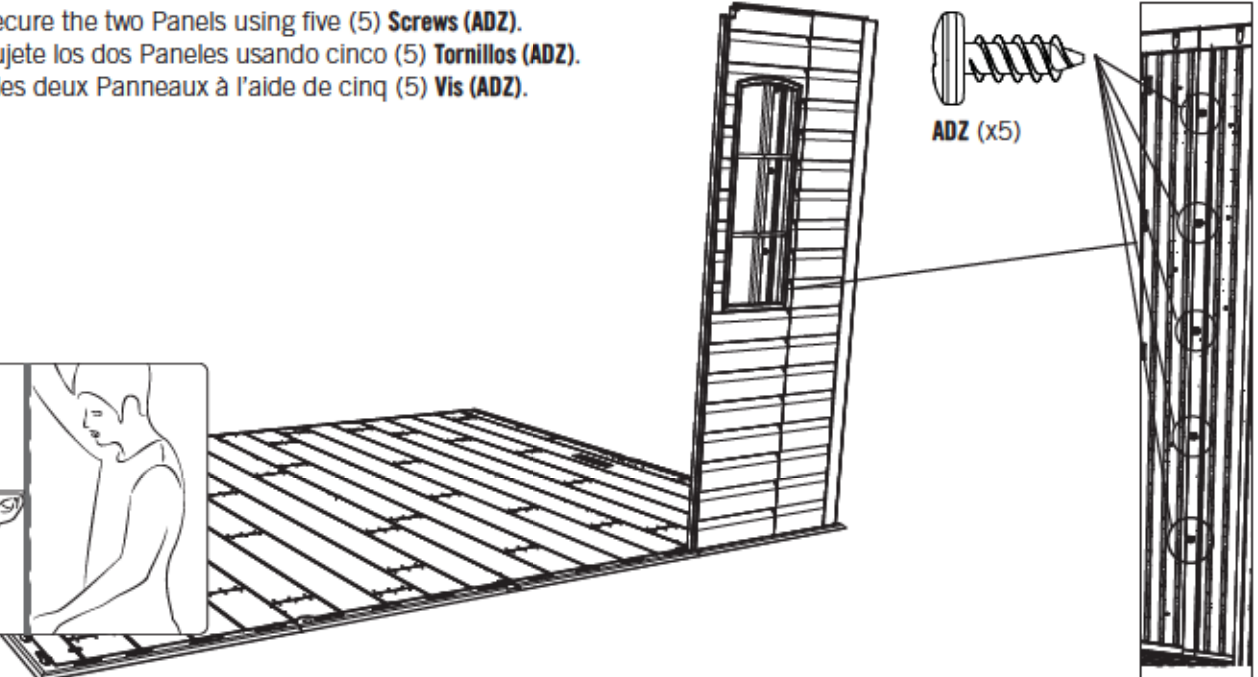
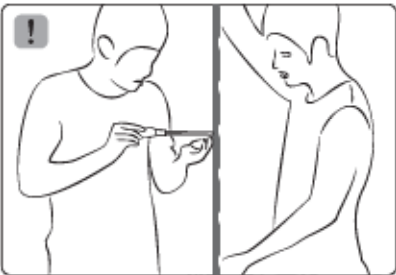

4.6

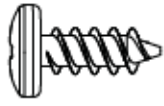

ADZ (x10)

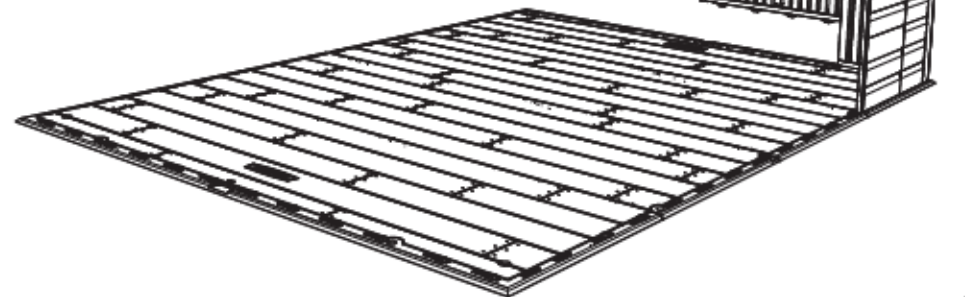
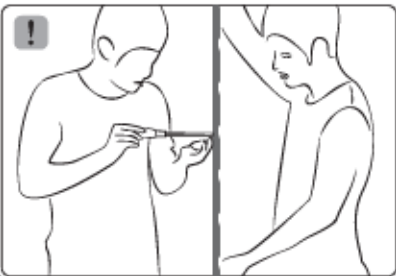
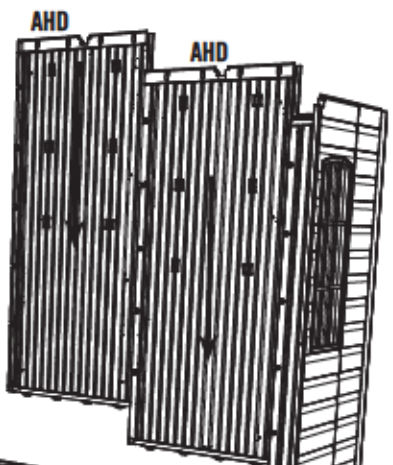



4



AIW (x1)

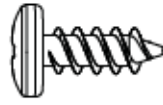

ADZ (x20)



4.7

• For the right, rear **Corner Panel (AGL)**, repeat the step you did for the right, front Corner Panel.

• Para el **Panel angular (AGL)** trasero derecho, repita los pasos que se efectuaron para el Panel angular delantero derecho.

• Pour le **Panneau angulaire (AGL)** arrière droit, répétez les étapes que vous avez réalisé pour le Panneau angulaire avant droit.

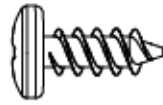

ADZ (x5)

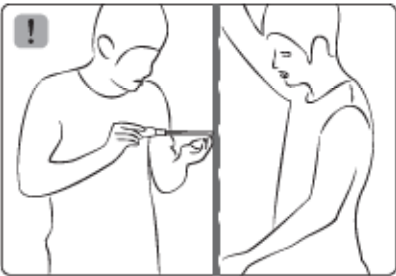
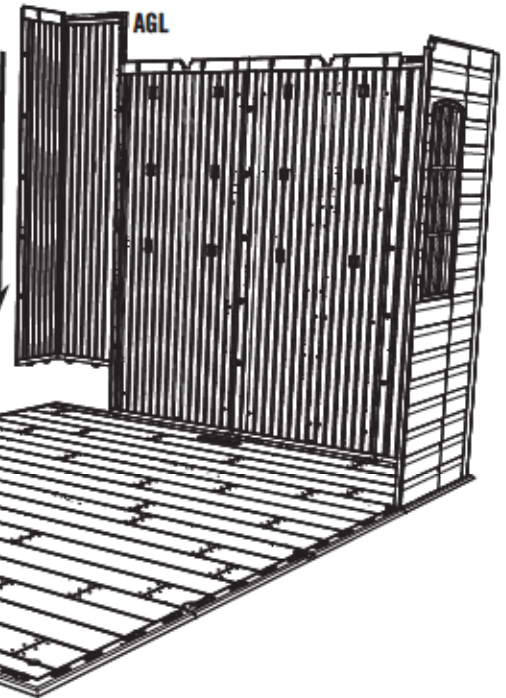

4.8

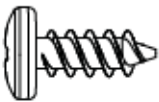

ADZ (x15)

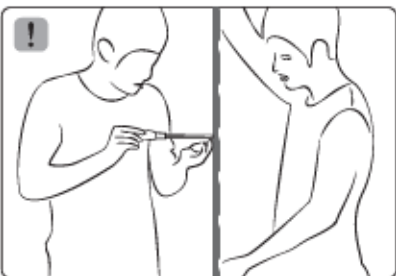
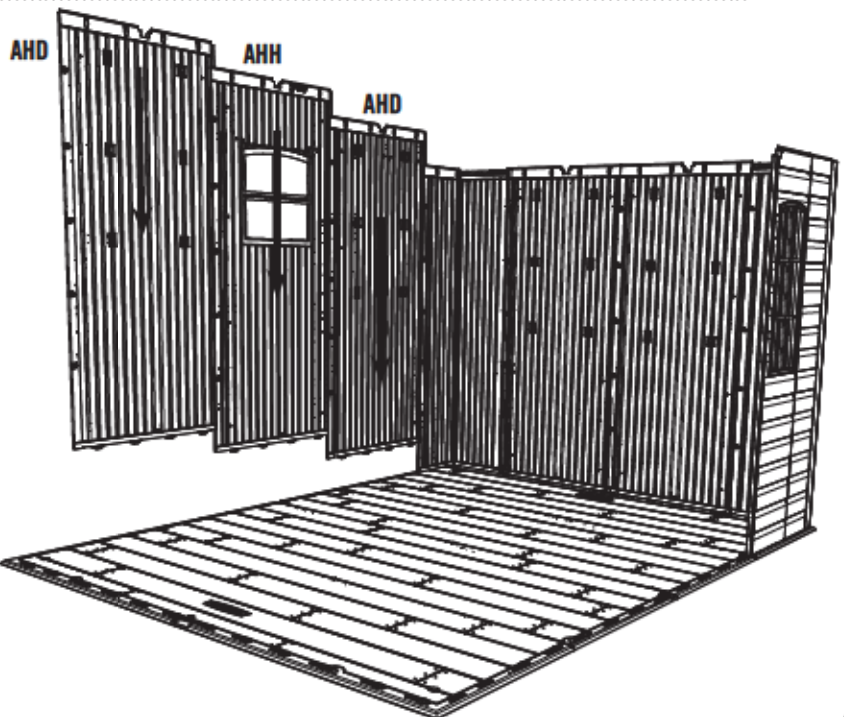



4



AIW (x1)



ADZ (x15)



4.9

• For the left, rear **Corner Panel (AGW)**, repeat the step you did for the right, front Corner Panel.

• Para el **Panel angular (AGW)** trasero izquierdo, repita los pasos que se efectuaron para el Panel angular delantero derecho.

• Pour le **Panneau angulaire (AGW)** arrière gauche, répétez les étapes que vous avez réalisé pour le Panneau angulaire avant droit.

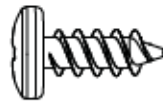

ADZ (x5)

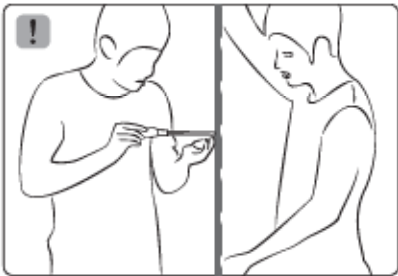
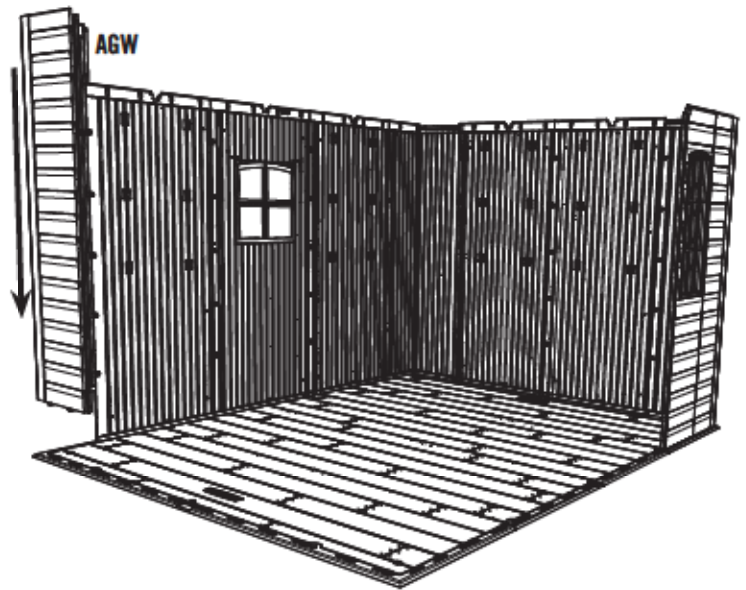

4.10

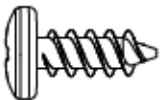

ADZ (x10)

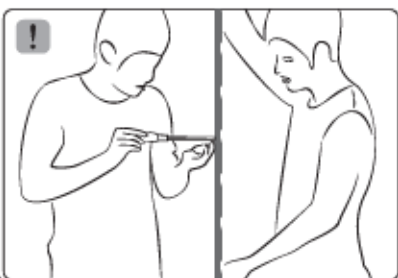
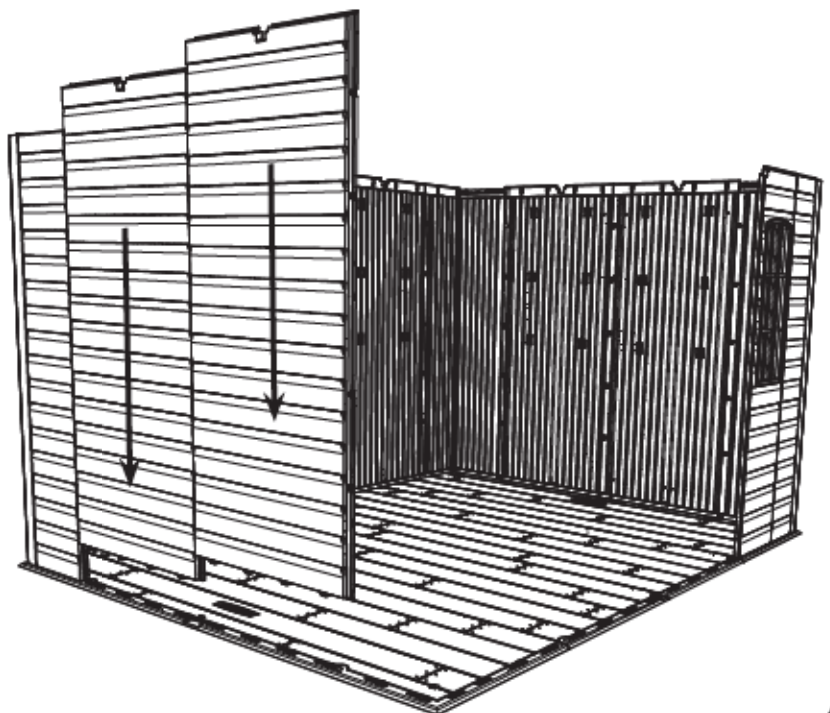

**4**

AIW (x1)

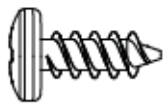

ADZ (x10)



4.11

• For the left, front **Corner Panel (AGL)**, repeat the step you did for the right, front Corner Panel.

• Para el **Panel angular (AGL)** delantero izquierdo, repita los pasos que se efectuaron para el Panel angular delantero derecho.

• Pour le **Panneau angulaire (AGL)** avant gauche, répétez les étapes que vous avez réalisé pour le Panneau angulaire avant droit.

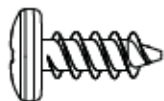
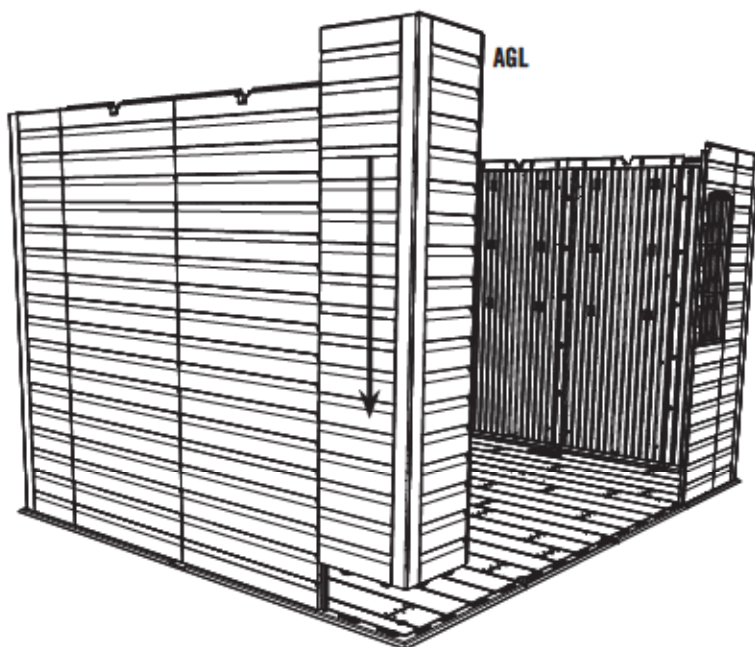

ADZ (x5)

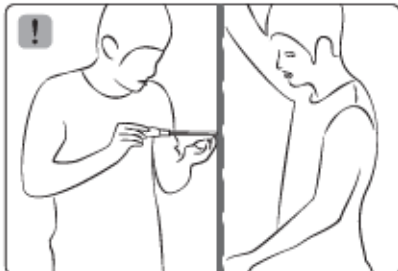

4.12

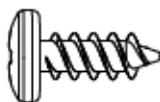

ADZ (x5)

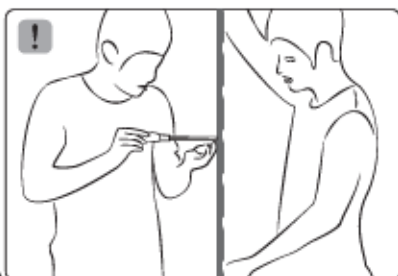
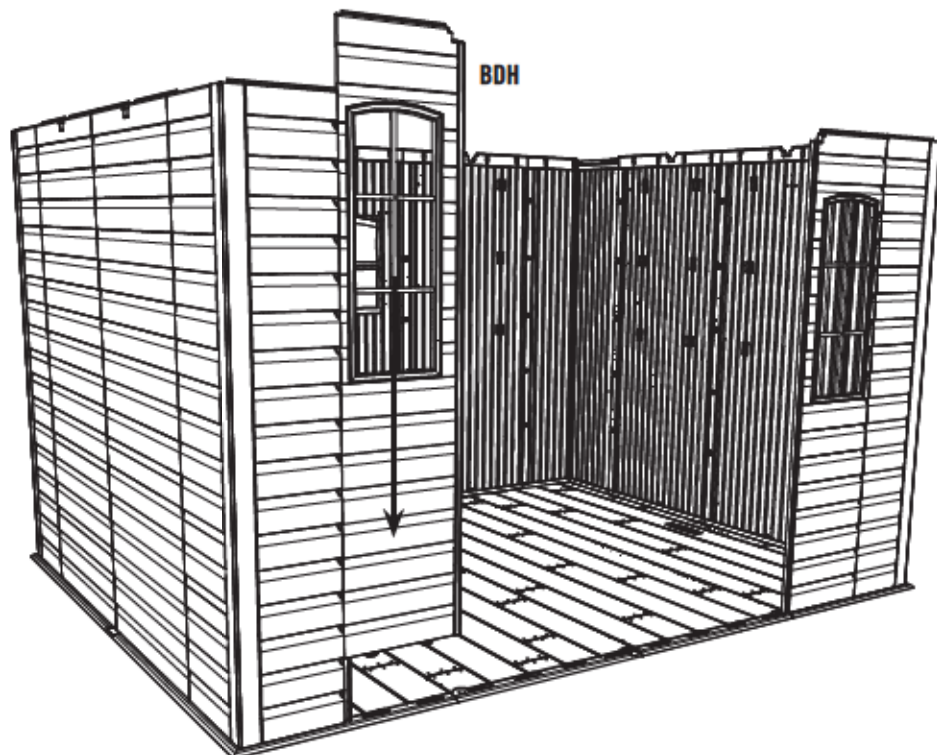



4

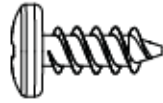

ADZ (x4)



4.13

• Four (4) **Screws (ADZ)** are used in the **Channel (AFM)**. The top hole does not use a Screw.

• Sujete el **Canal (AFM)** usando cuatro (4) **Tornillos (ADZ)**. No inserte un Tornillo en el agujero superior.

• Attachez bien le **Support (AFM)** à l'aide de quatre (4) **Vis (ADZ)**. Ne pas insérer une Vis à travers le trou supérieur.

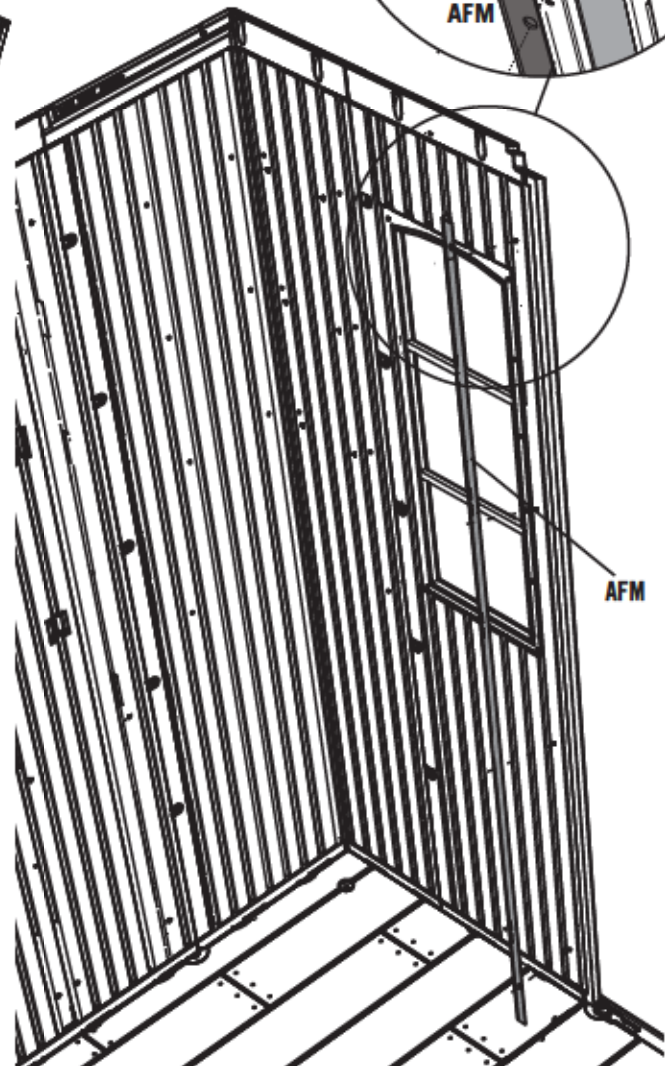
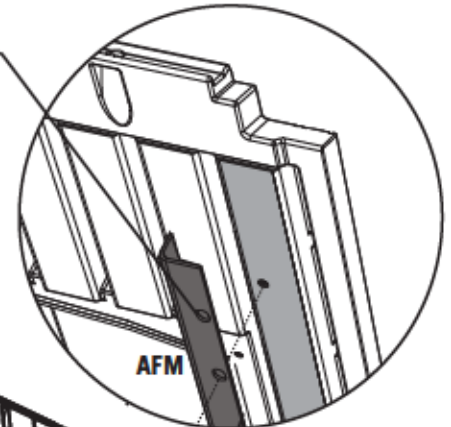
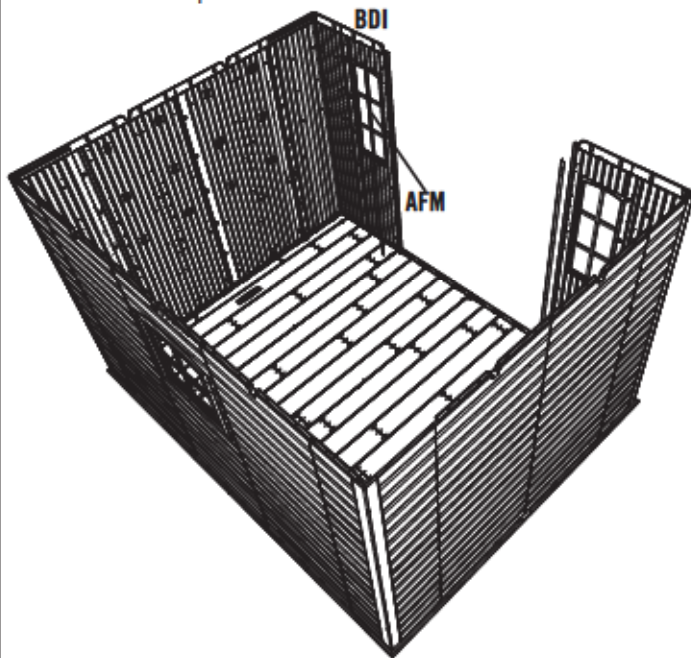



4

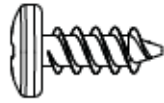

ADZ (x4)



4.14

• Four (4) Screws (ADZ) are used in the Channel (AFM). The top hole does not use a Screw.

• Sujete el Canal (AFM) usando cuatro (4) Tornillos (ADZ). No inserte un Tornillo en el agujero superior.

• Attachez bien le Support (AFM) à l'aide de quatre (4) Vis (ADZ). Ne pas insérer une Vis à travers le trou supérieur.

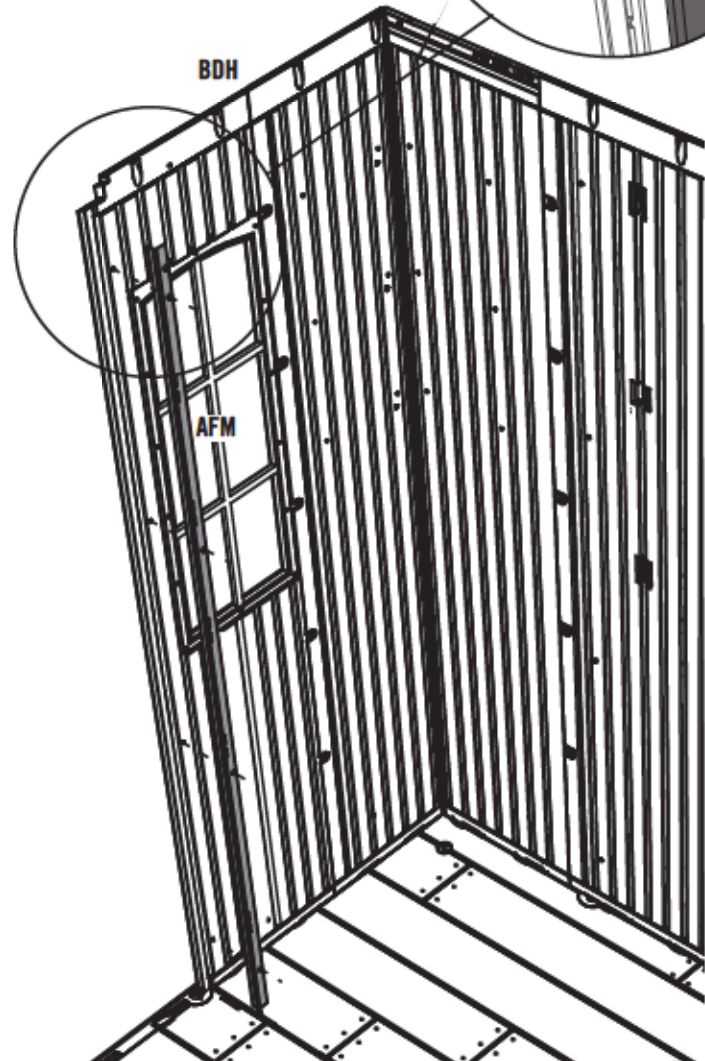
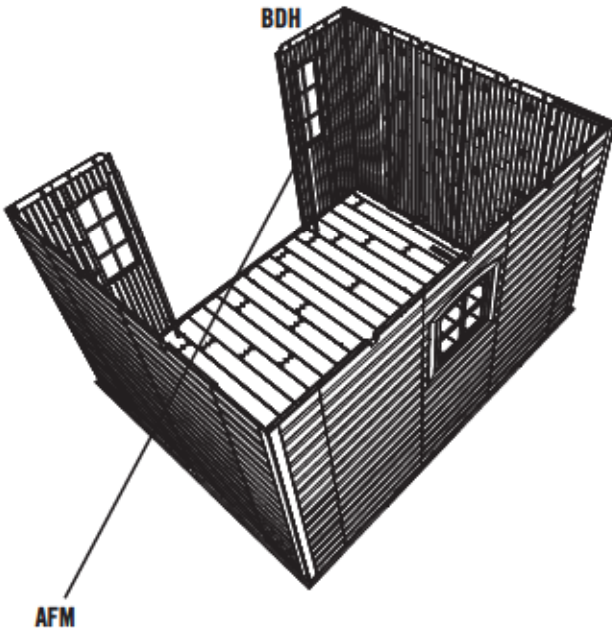
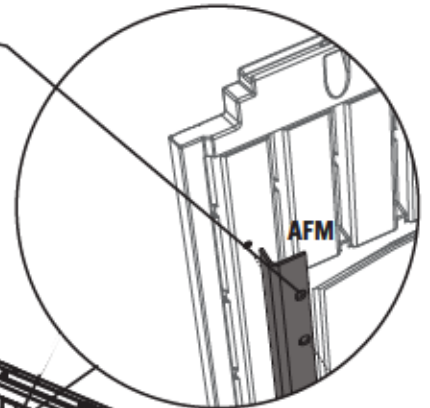



4

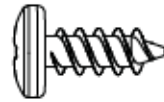

ADZ (x8)



4.15

• Insert the **Wall Support Channels (AFM)** into the grooves directly under the notches in the Wall Panels. Secure each with four (4) **Screws (ADZ)**.

• Inserte los **Soportes de los paneles de pared (AFM)** en las ranuras directamente debajo las muescas en los Paneles de pared. Sujételos con cuatro (4) **Tornillos (ADZ)**.

• Insérez les **Supports des Panneaux muraux (AFM)** dans les rainures directement sous les encoches des Panneaux muraux. Attachez-les bien à l'aide des quatre (4) **Vis (ADZ)**.

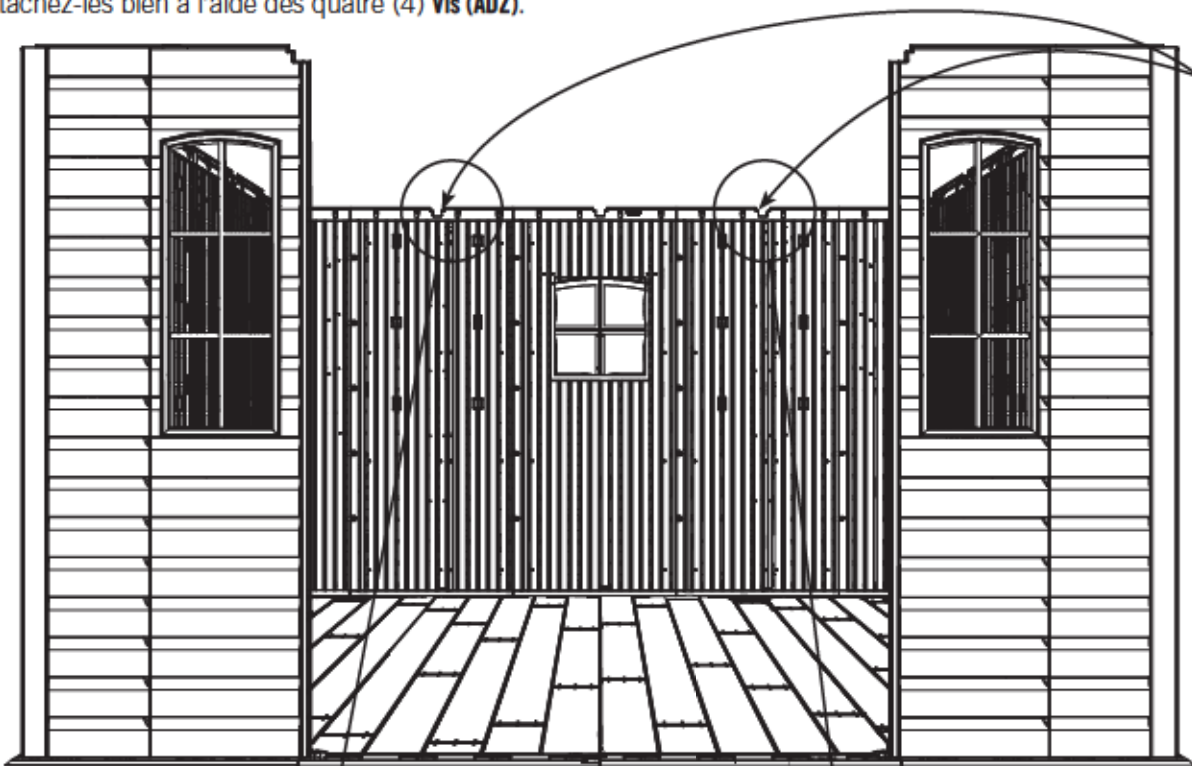

67 3/4" (1,72 m)

AFM

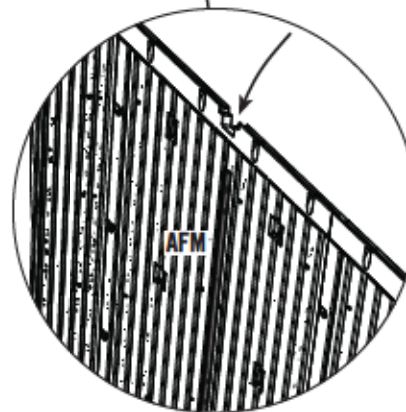
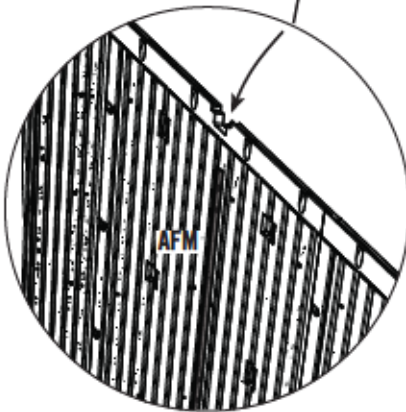

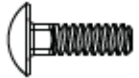

ACR (x24)



ADK (x24)



AEE (x24)



AHI (x2)



Plastic Pieces / Piezas de plástico / Pièces en plastique

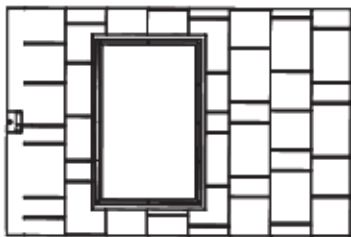

AHB (x2)

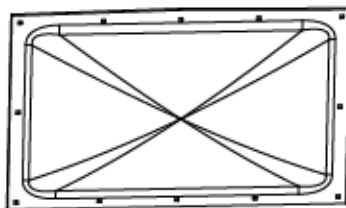

AGB (x2)



3/8" (10 mm)

**5****AHI (x2)****5.1**

• Remove any excess plastic from the holes, but the holes must remain square.

- Retire cualquier plástico en exceso de los agujeros, mas los agujeros deben quedarse cuadrados.
- Enlevez de l'excès de plastique des trous, mais les trous doivent rester carrés.

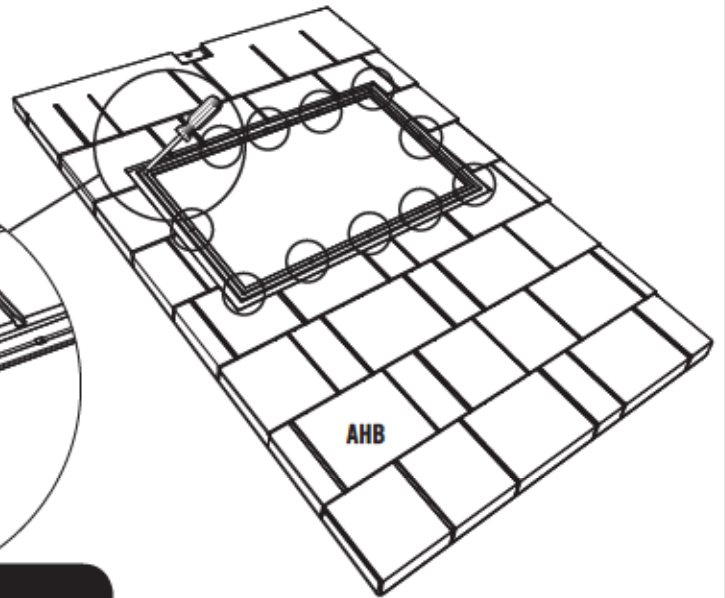
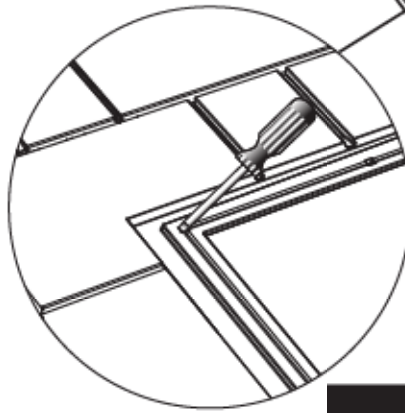
**5.2**

• Lay the **Butyl Tape (AHI)** over the groove along the edge of the opening in the Roof Panel.

- Coloque la **Cinta butílica (AHI)** sobre la ranura a lo largo del borde de la abertura del Panel de techo.
- Mettez le **Ruban butyl (AHI)** sur la rainure le long du bord de l'ouverture du Panneau de toit.

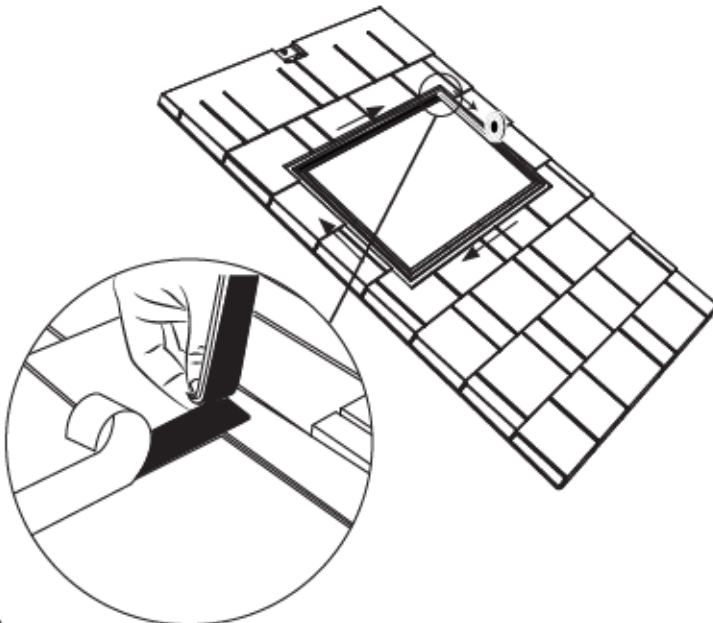
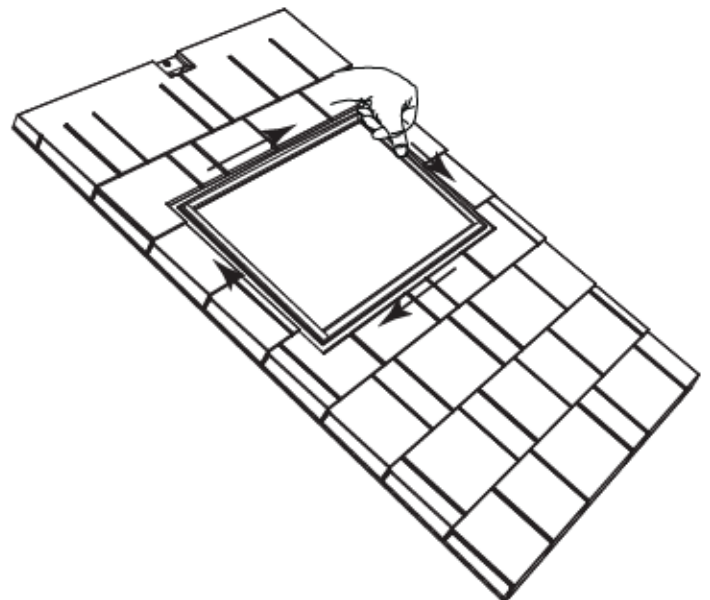
**5.3**

**5**

5.4

• Using a plain screwdriver, poke holes through the Butyl Tape and through the holes in the Roof Panel. The holes in the Roof Panel must remain square.

- Mete un destornillador de punta plana a través de la Cinta butilo y los agujeros cuadrados en el Panel de tejado. Los agujeros en el Panel de tejado deben quedarse cuadrados.
- Mettez un Tournevis plat dans le Ruban butylique et à travers les trous carrés dans le Panneau de toit. Les trous dans le Panneau de toit doivent rester carrés.

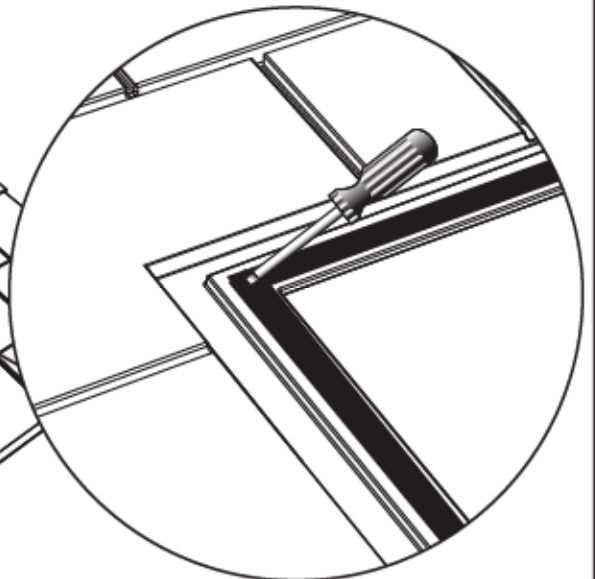
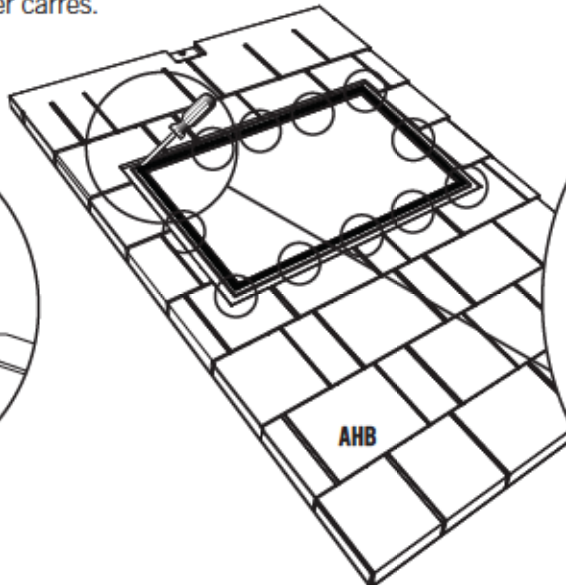

5.5

- Remove any bubbles between the Skylight and the Butyl tape.
- Retire las burbujas entre el Tragaluz en forma de cúpula y la Cinta butilo.
- Retirez les bulles entre la Lucarne en dôme et le Ruban butylique.

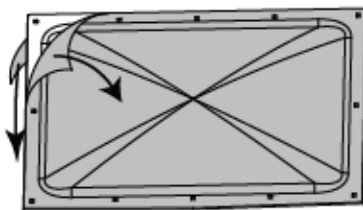
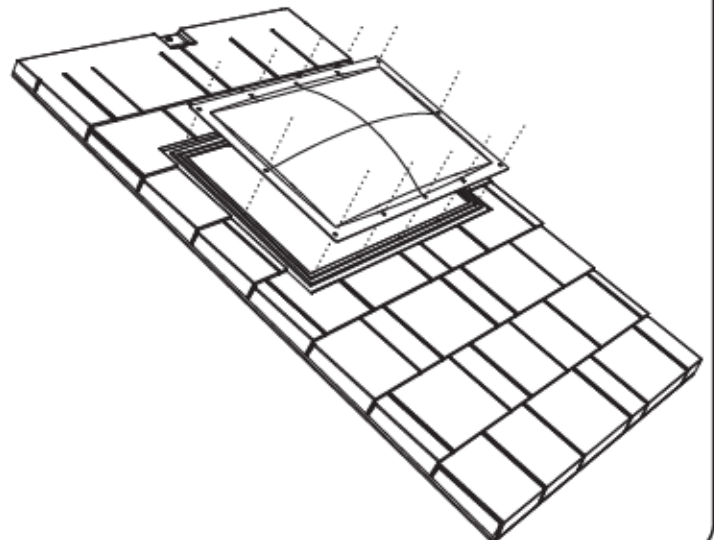
**AGB**



5



3/8"
(10 mm)

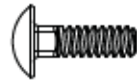

ACR (x24)



ADK (x24)



AEE (x24)



5.6

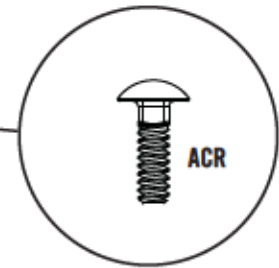
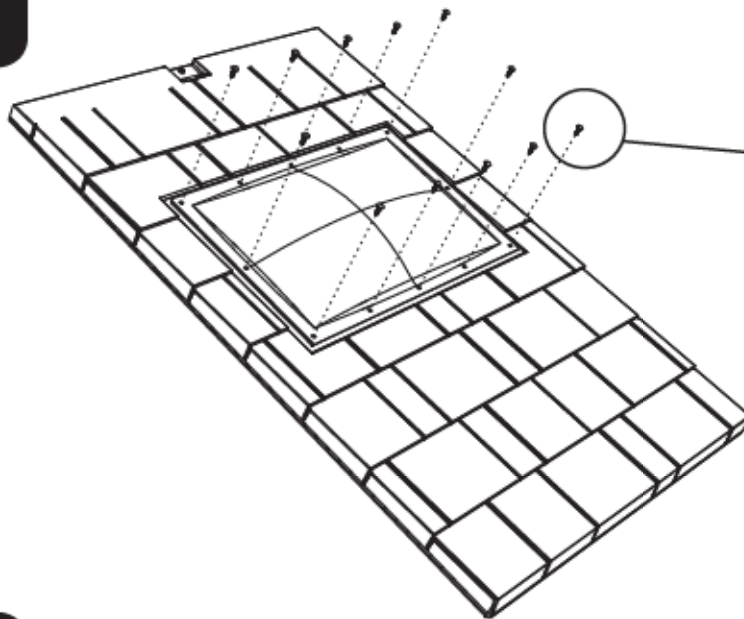

5.7

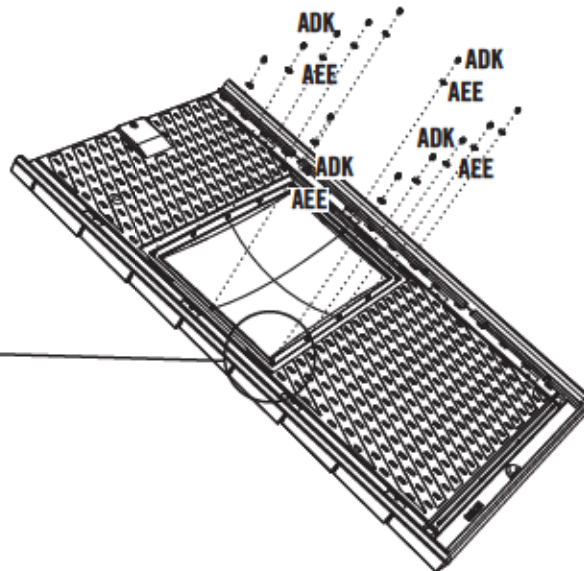
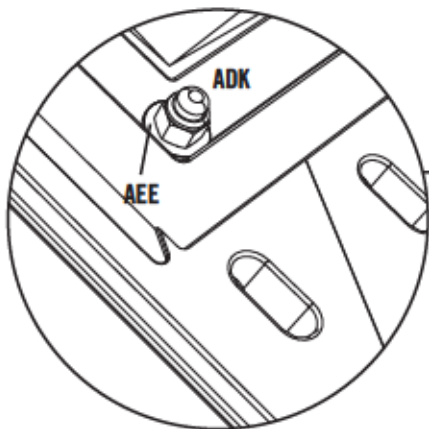

5.1 - 5.7 X2!



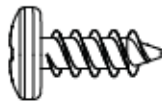

ADZ (x8)

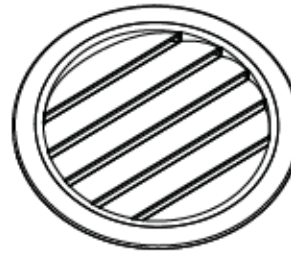

AGP (x2)

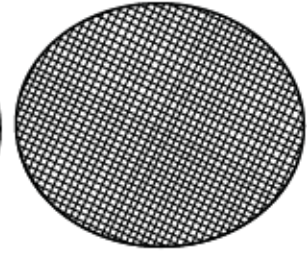

AIQ (x2)



ADW (x10)



AEE (x10)

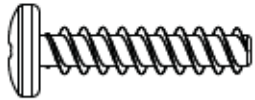

ADV (x4)



AHS (x2)

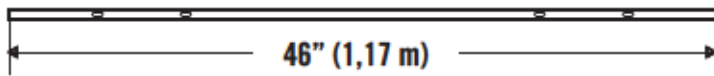

BDD (x1)

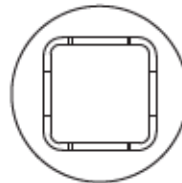

BDC (x1)

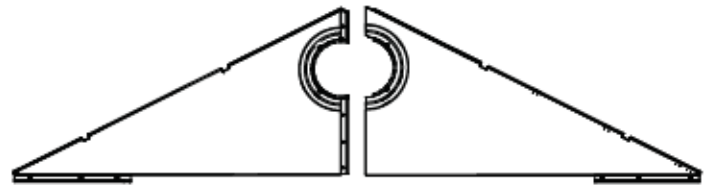

AGI (x2)

AGH (x2)





6

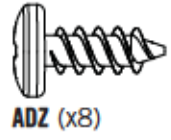
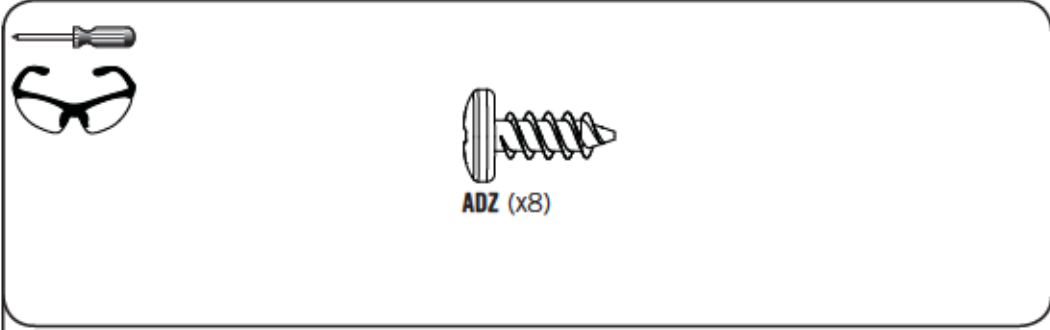

6.1

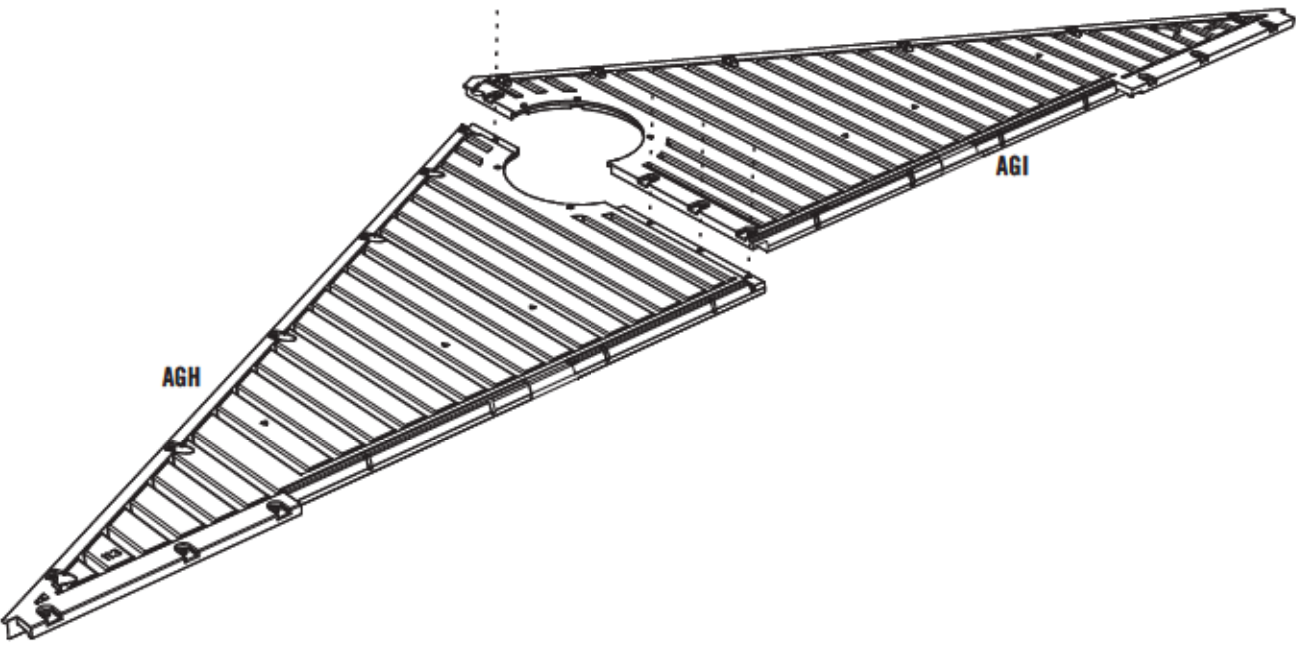

6.2

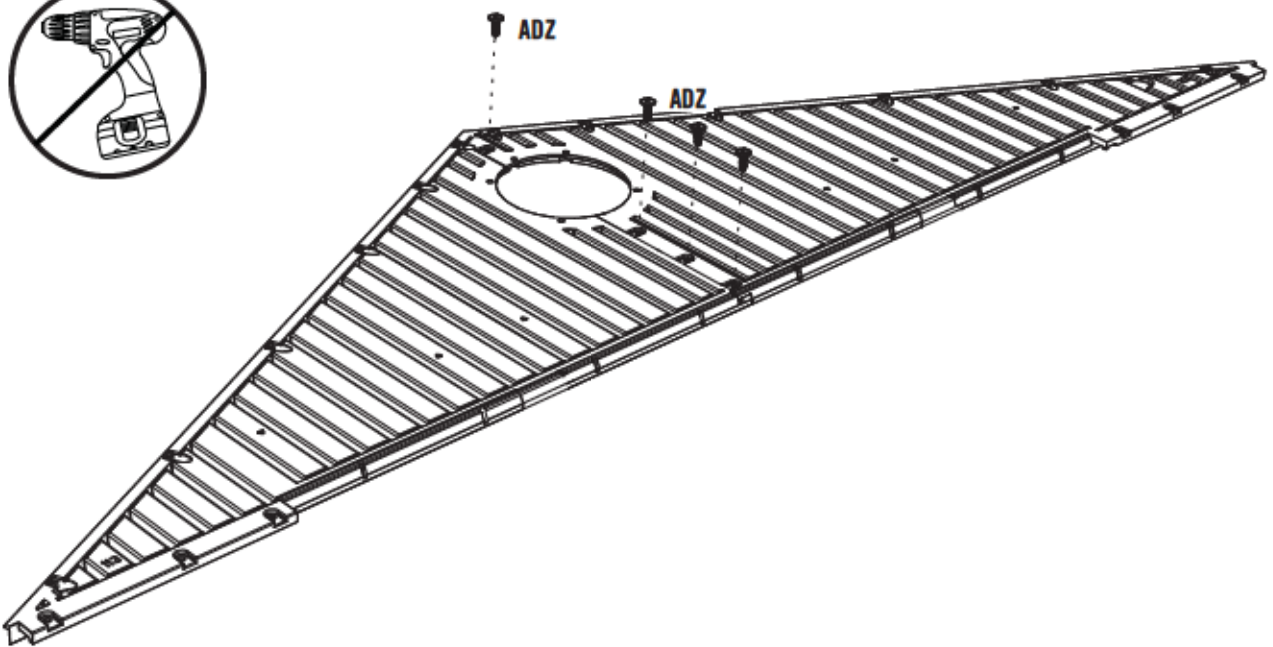



6

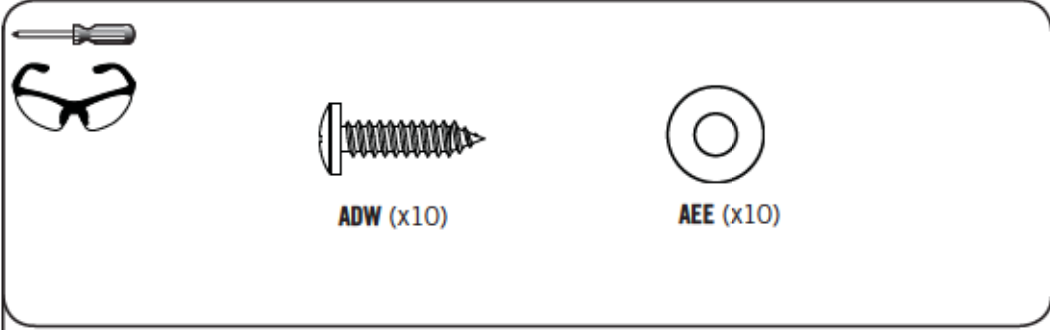

ADW (x10)



AEE (x10)



6.3

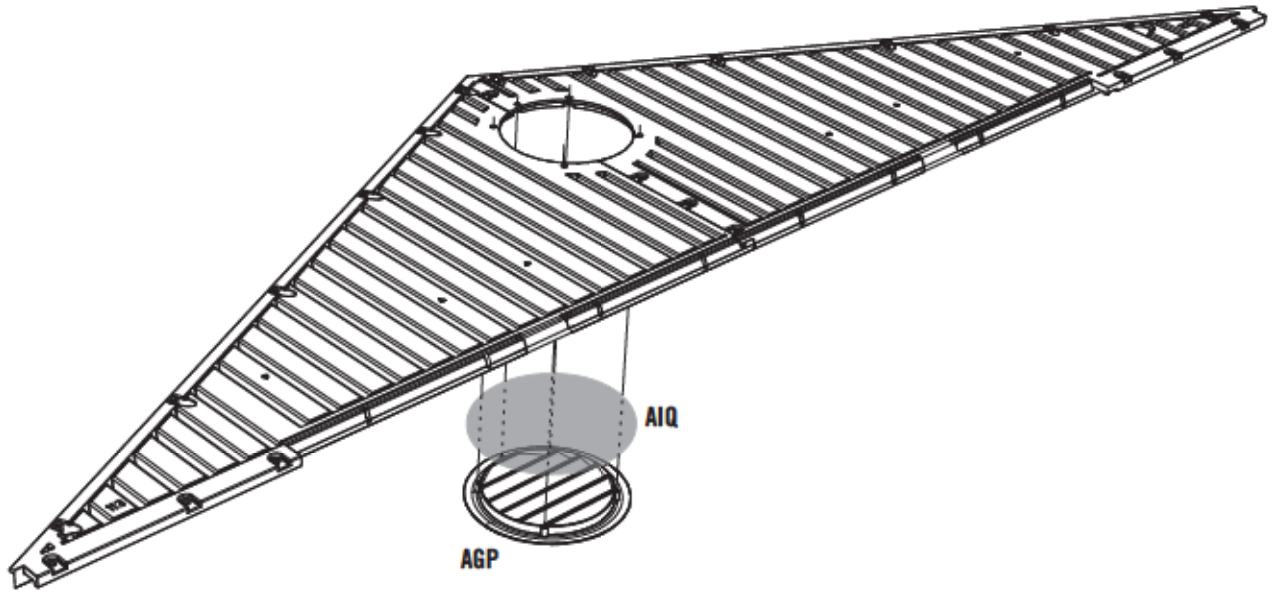

6.4

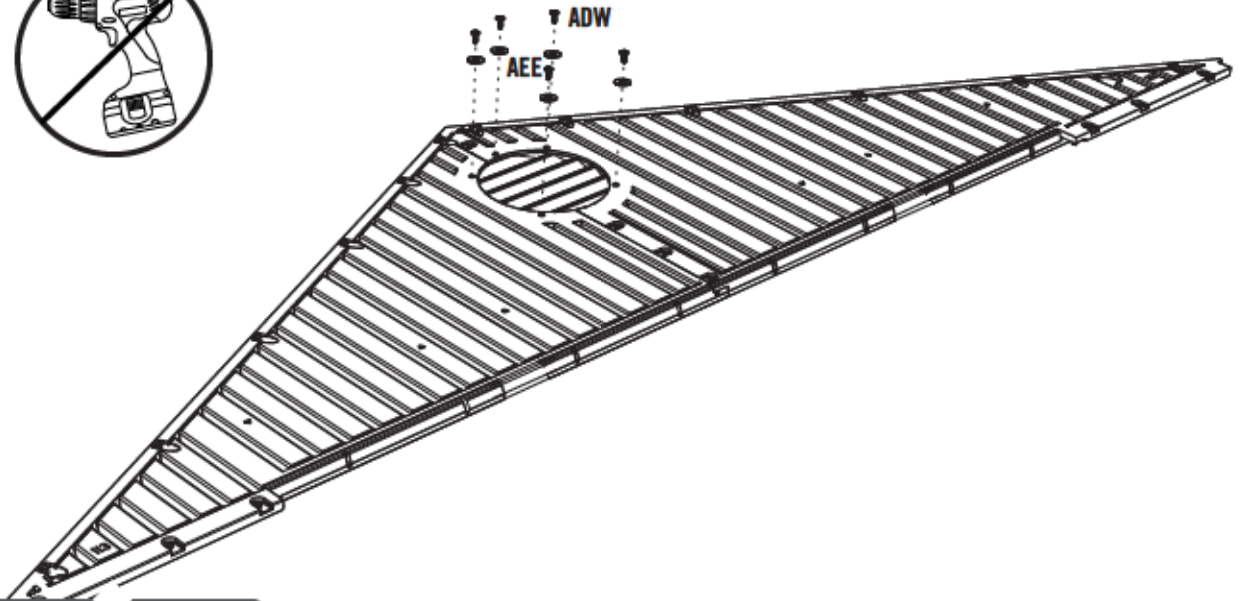

6.1 - 6.4 X2!



6



AHS (x2)



ADV (x4)



6.5

- The flat holes face away from the Gable.
- Los agujeros planos dan hacia afuera.
- Les trous plats doivent être face à l'écart du Toit à pignon.

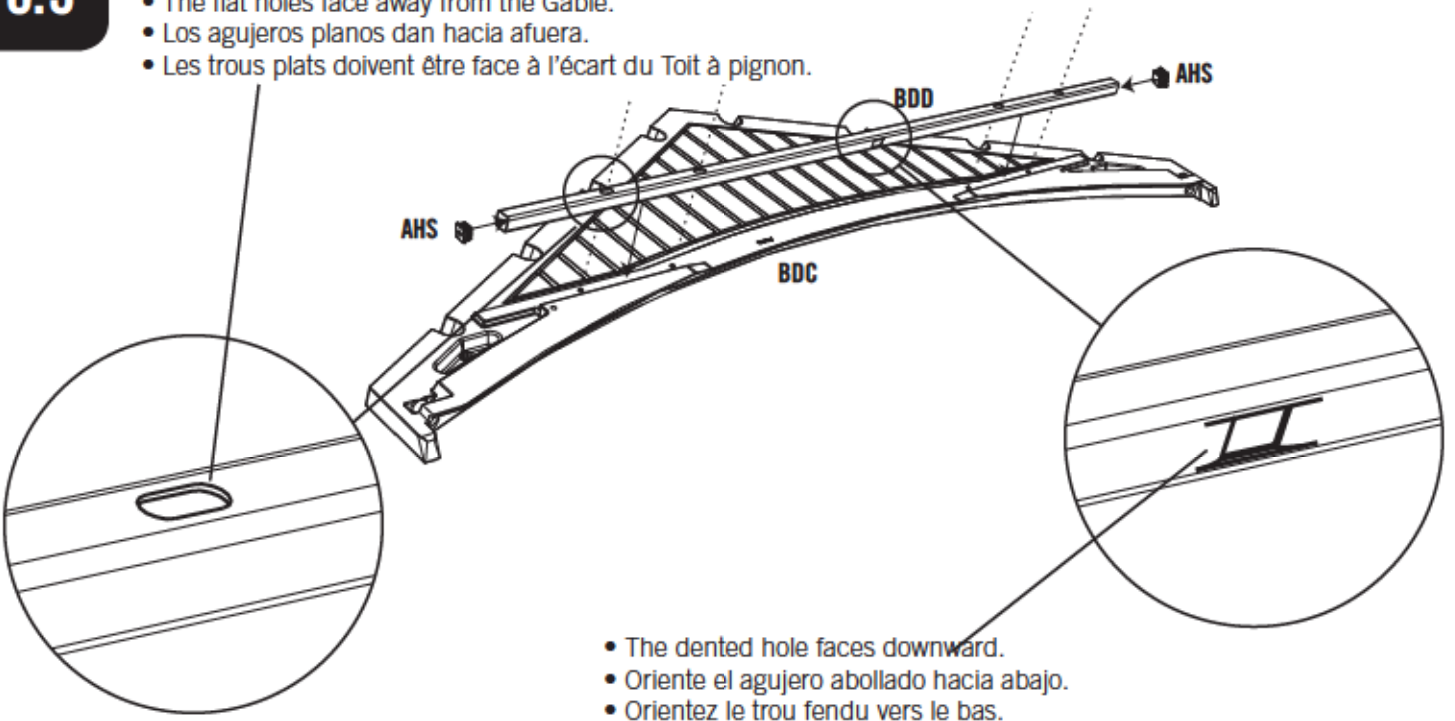

- The dented hole faces downward.
- Oriente el agujero abollado hacia abajo.
- Orientez le trou fendu vers le bas.

6.6

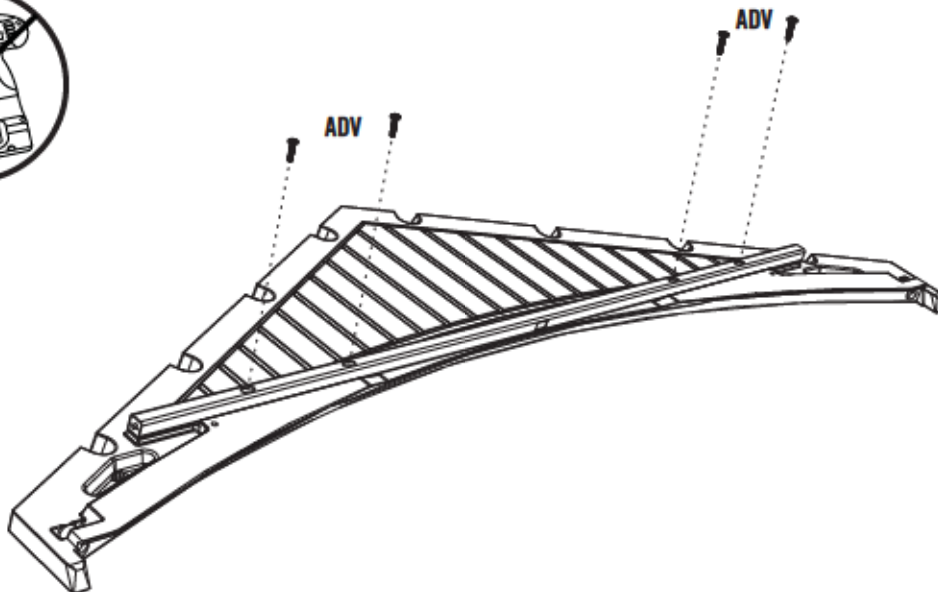

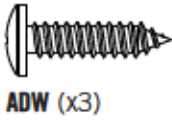

ADW (x3)



ABU (x2)



ADJ (x2)



AEE (x3)



AHM (x2)



AIA (x1)

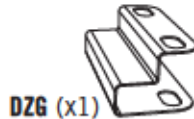

DZG (x1)

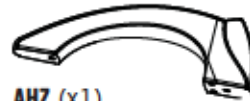

AHZ (x1)



Metal Pieces / Piezas de metal / Pièces en métal

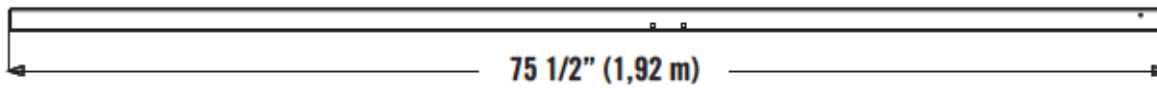

BLH (x1)

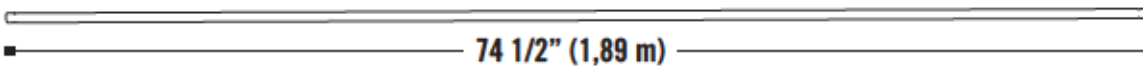
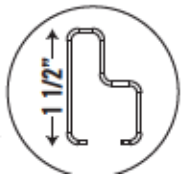

CRE (x1)



Plastic Piece / Pieza de plástico / Pièce en plastique

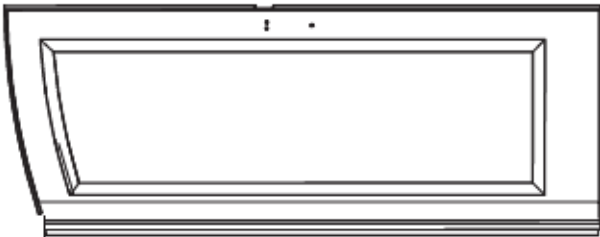

BDJ (x1)



7/16" (11 mm)



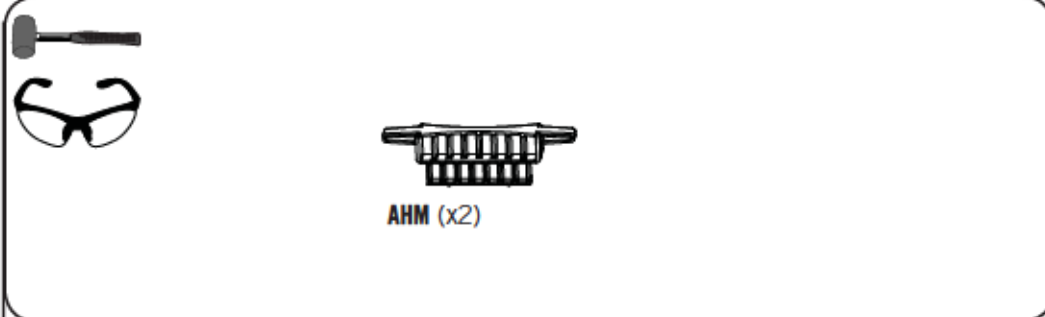

7.1

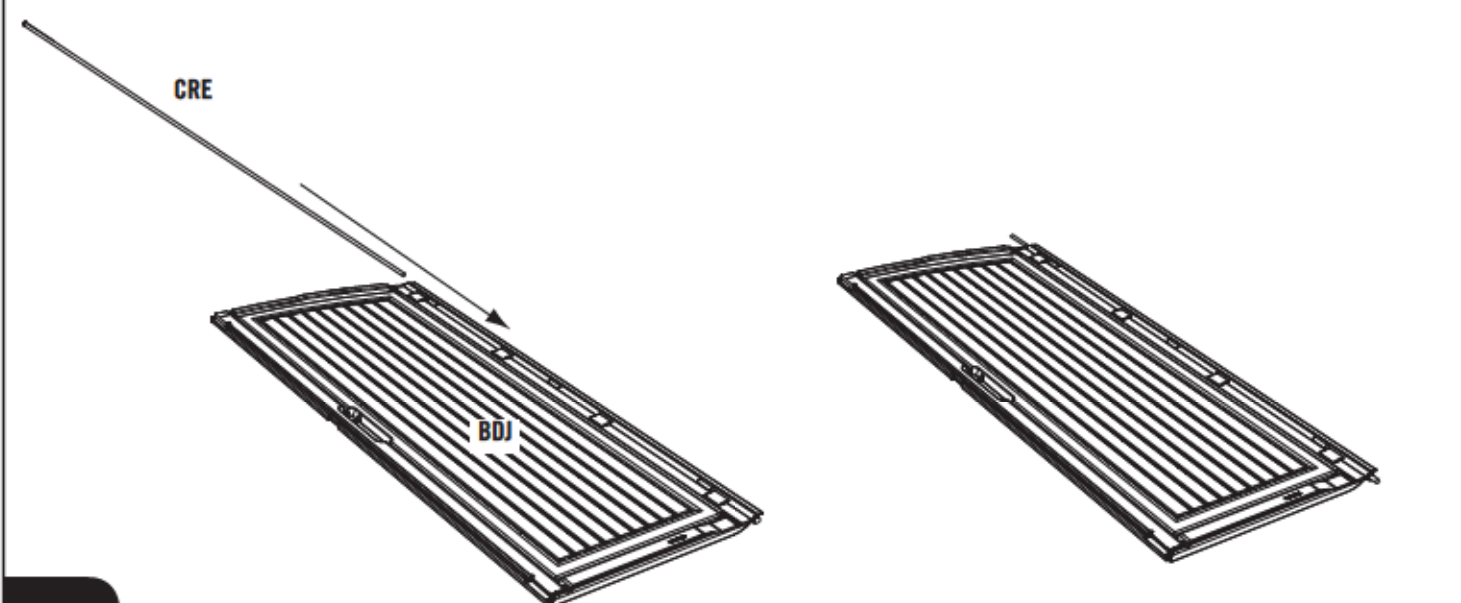

7.2

• Set the **Deadbolts (AHM)** down into the notches at the top and bottom of the Door. Then, slide the **Door End Channel (AFC)** over the edge of the Door and the bottom of the Deadbolts as shown.

- Ponga los **Cerrojos (AHM)** en las muescas a las partes superior et inferior de la Puerta. Entonces, deslice el **Canal para el borde de la puerta (AFC)** sobre el borde de la Puerta y las partes inferiores de los Cerrojos como se muestra.
- Mettez les **Loquets à pêne dormant (AHM)** dans les encoches aux parties supérieure et inférieure de la Porte. Ensuite, faites glisser le **Canal d'extrémité de la porte (AFC)** sur le bord de la Porte et les parties inférieures des Loquets à pêne dormant comme illustré.

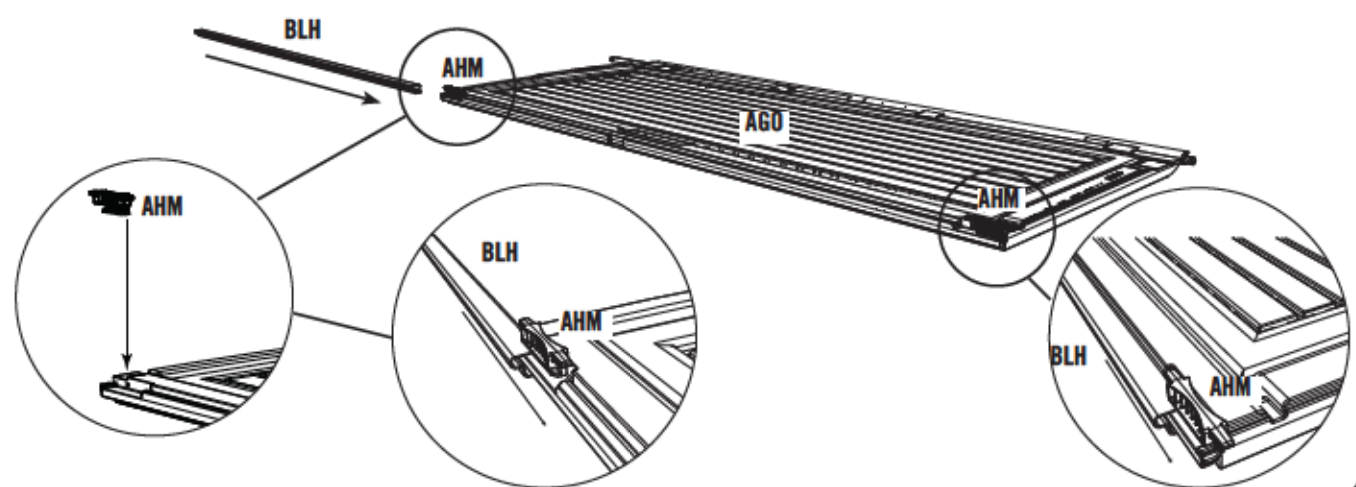



7

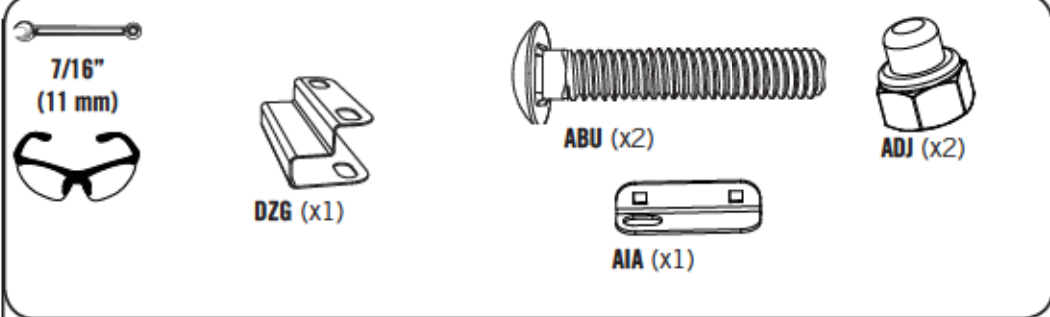

7.3

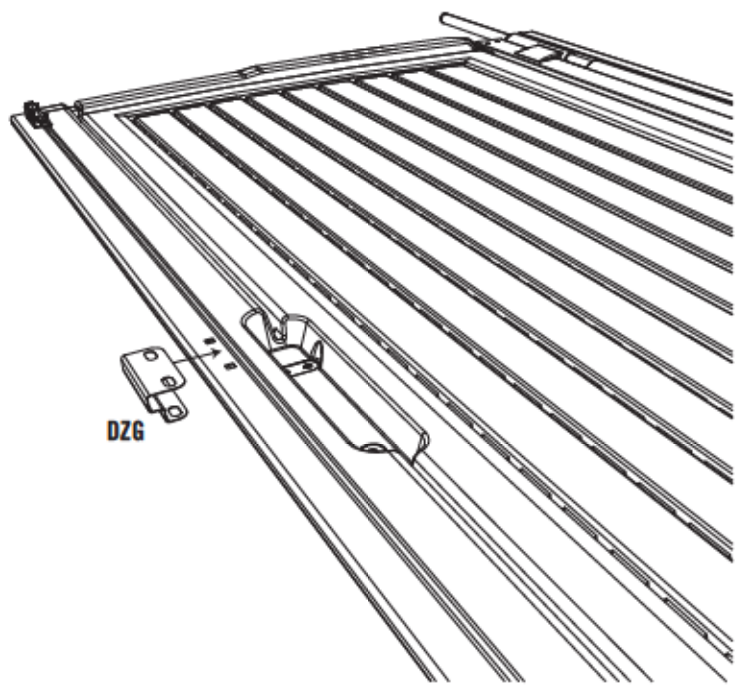

7.4

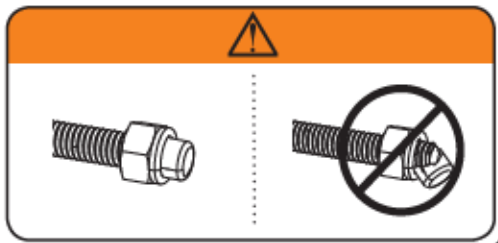
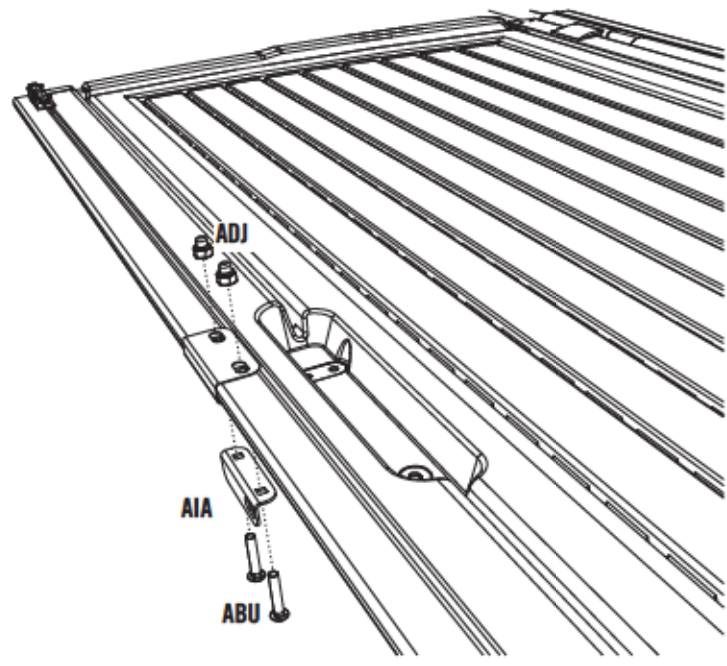

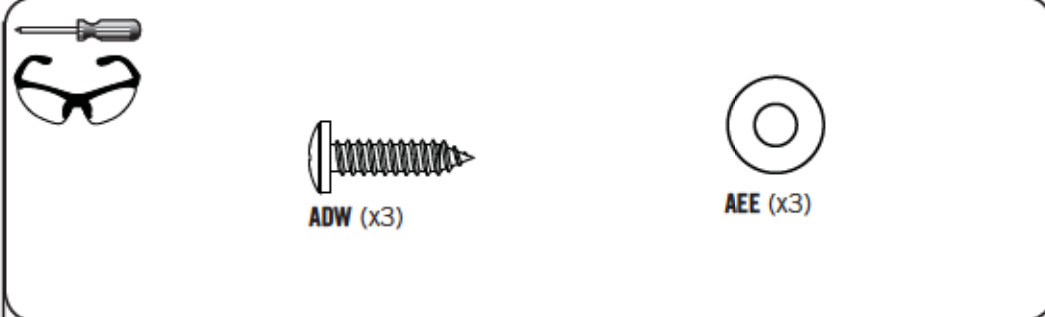

7.5

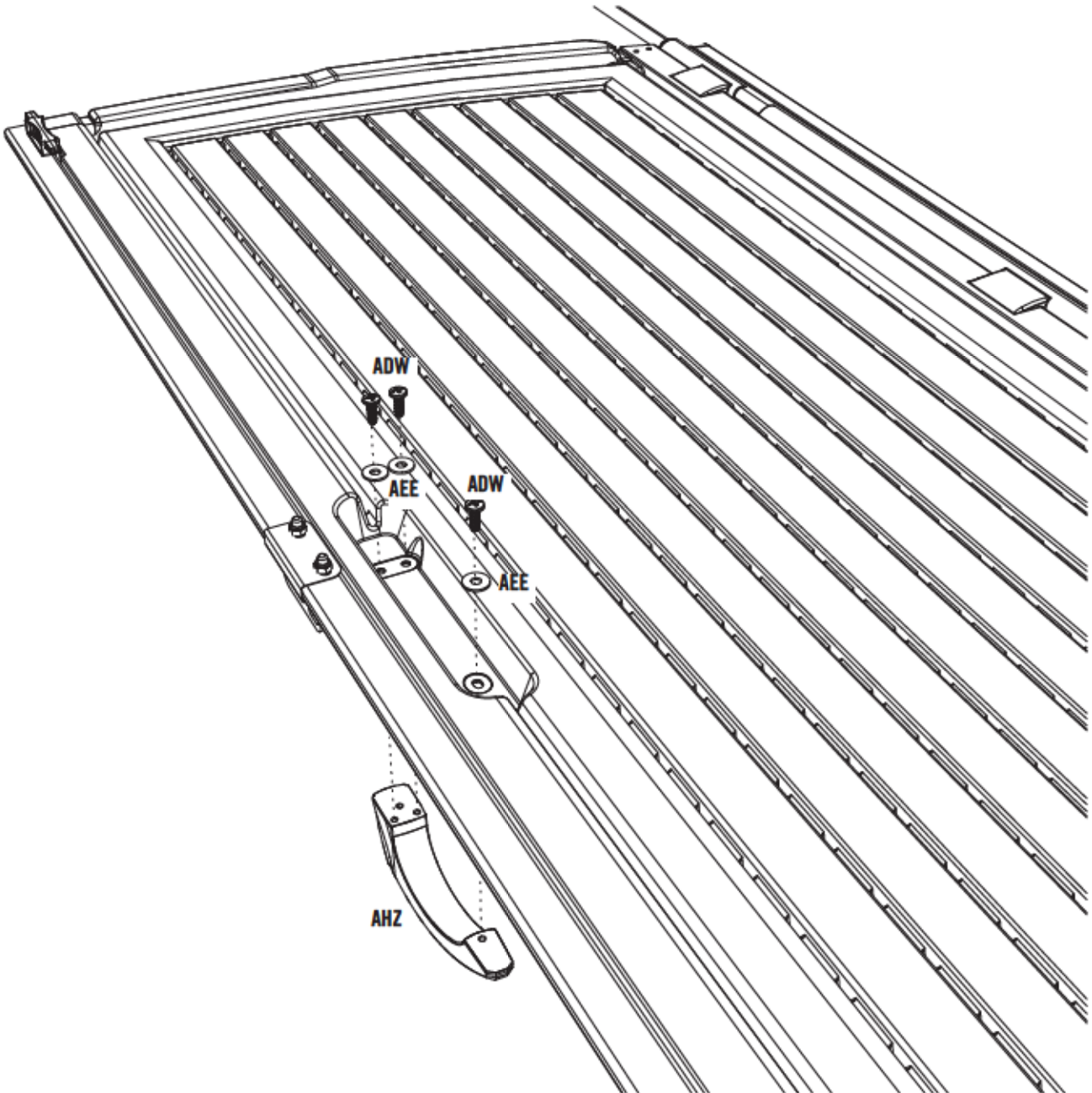

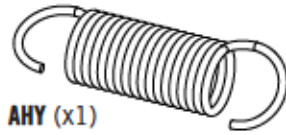

AHY (x1)



AEE (x5)



ADB (x2)



AAB (x2)



ABV (x2)



ADW (x4)

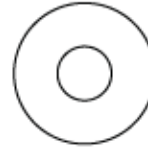

AEB (x2)

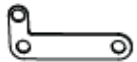

AHX (x1)



AIL (x1)

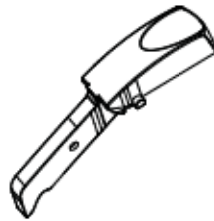

AIO (x1)

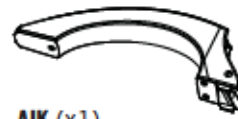

AIK (x1)



AHV (x1)

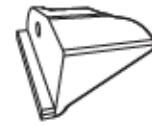

AHW (x1)



Metal Pieces / Piezas de metal / Pièces en métal

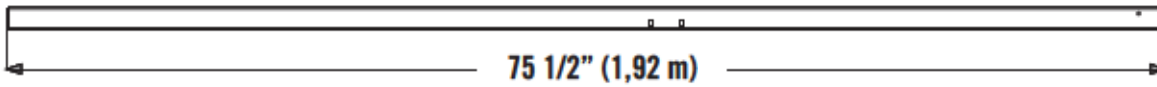

BLH (x1)

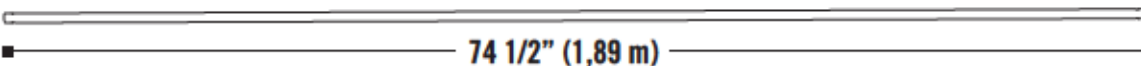
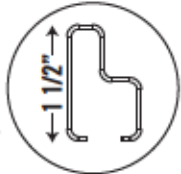

CRE (x1)



Plastic Piece / Pieza de plástico / Pièce en plastique

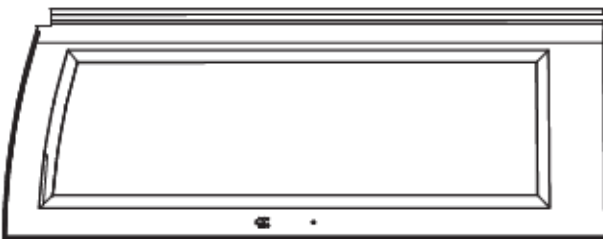

BDK (x1)



7/16" (11 mm)





8.1

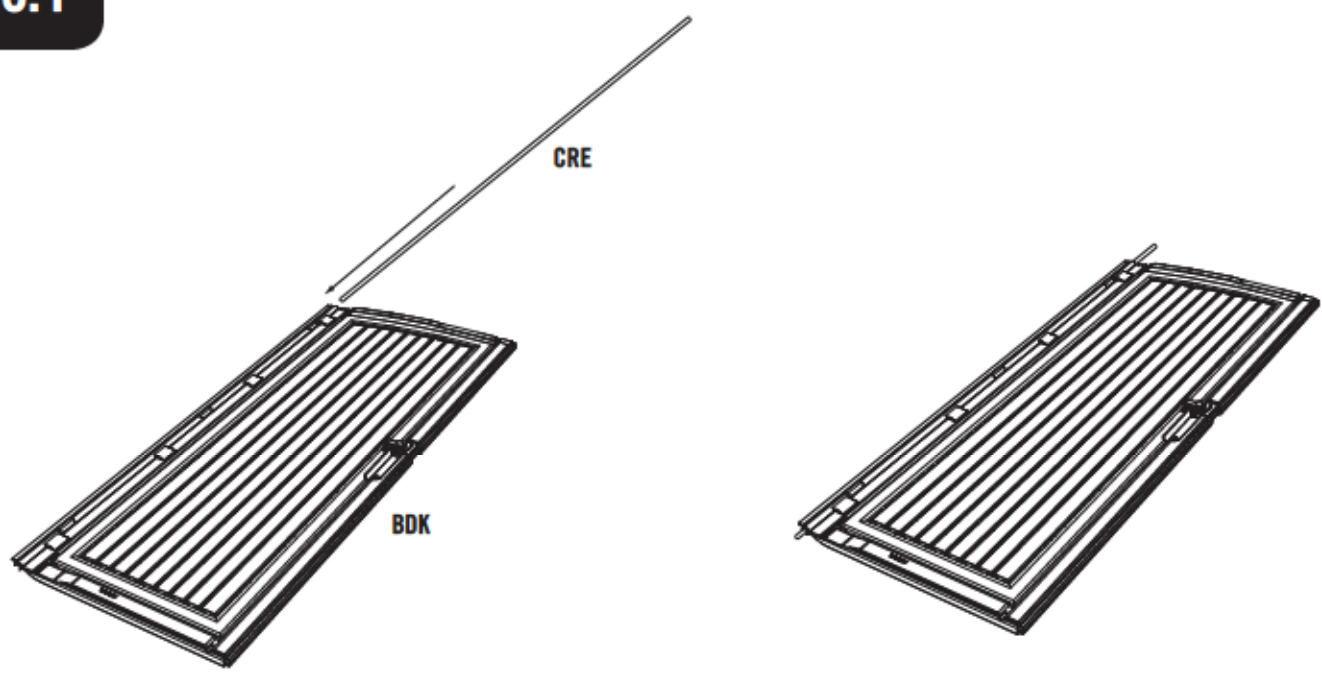

8.2

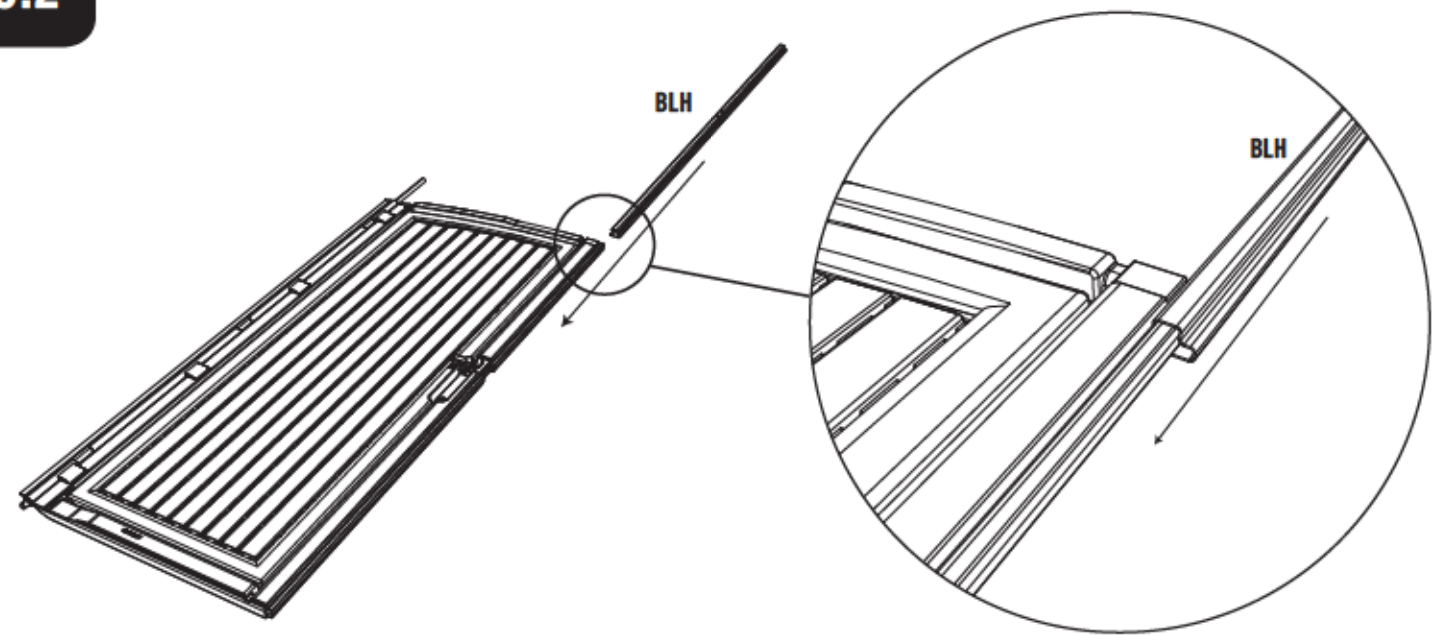



8

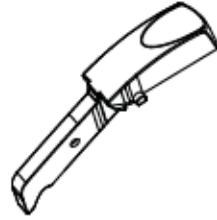

AIO (x1)

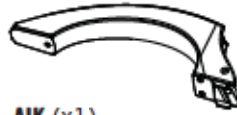

AIK (x1)



8.3

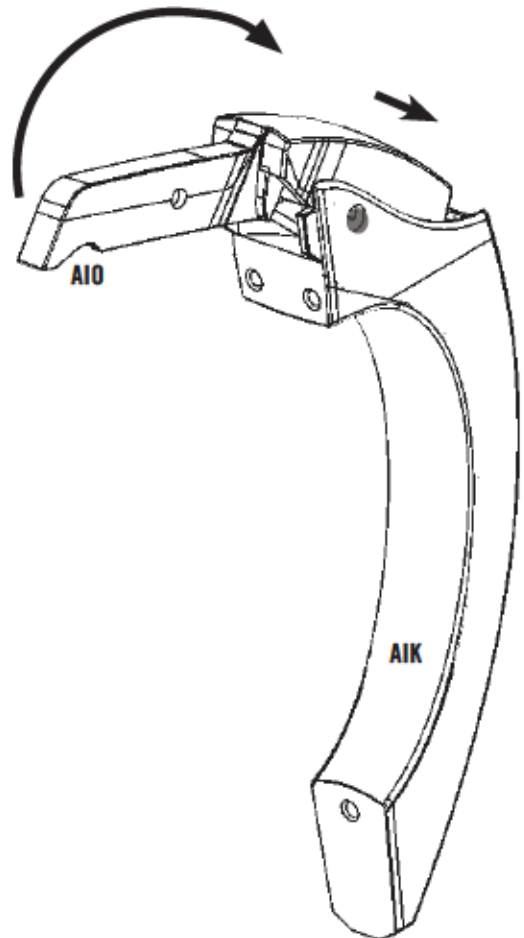
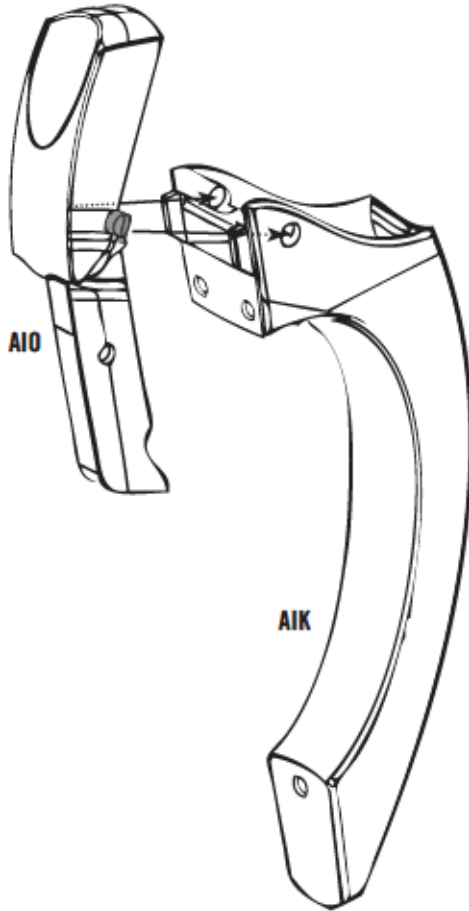



8

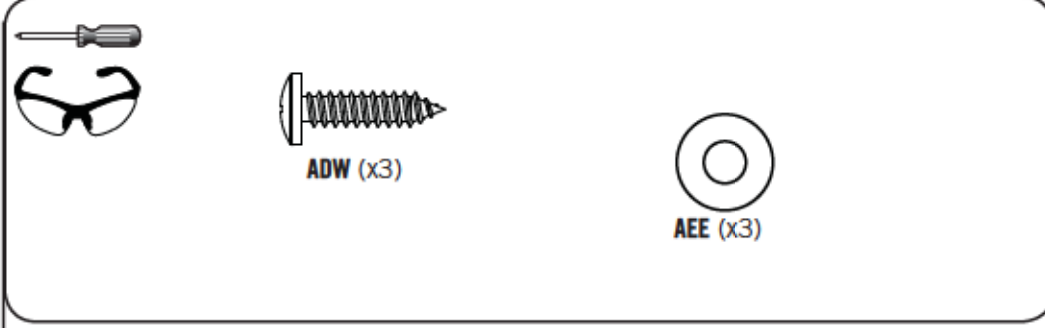

8.4

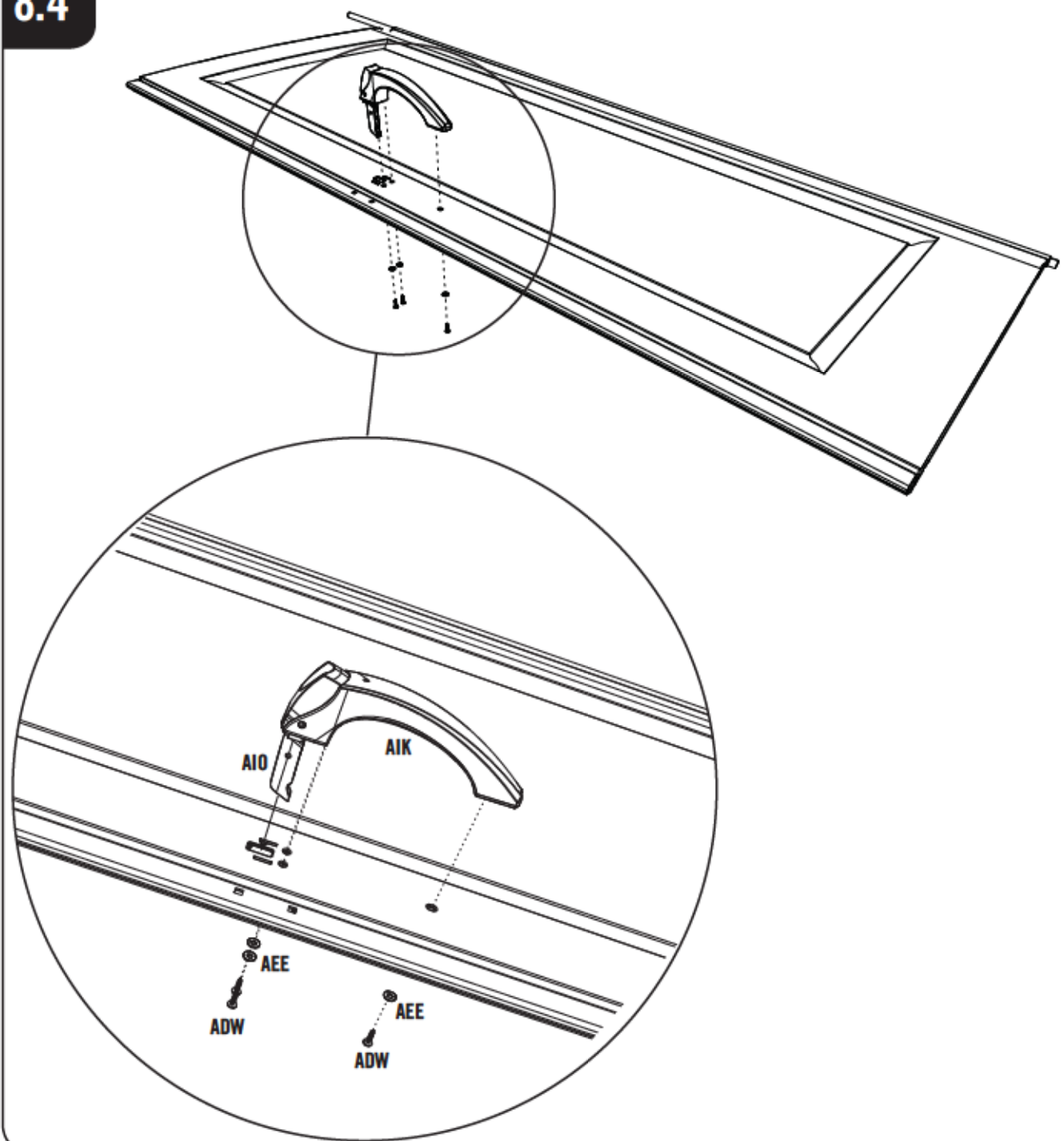



8

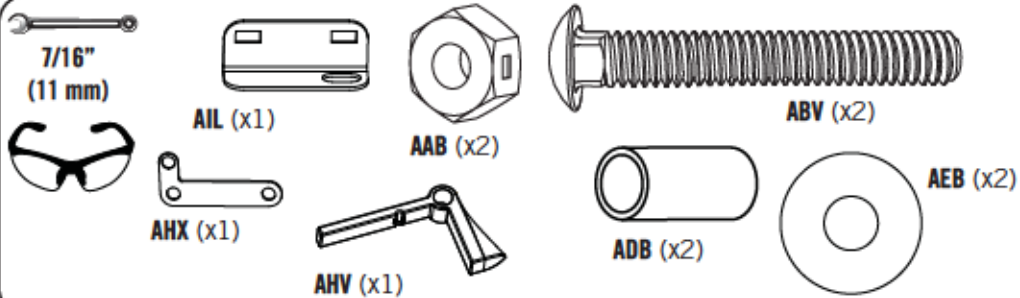

8.6

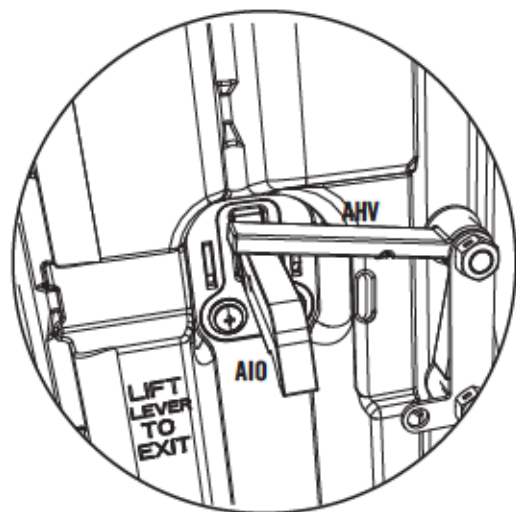
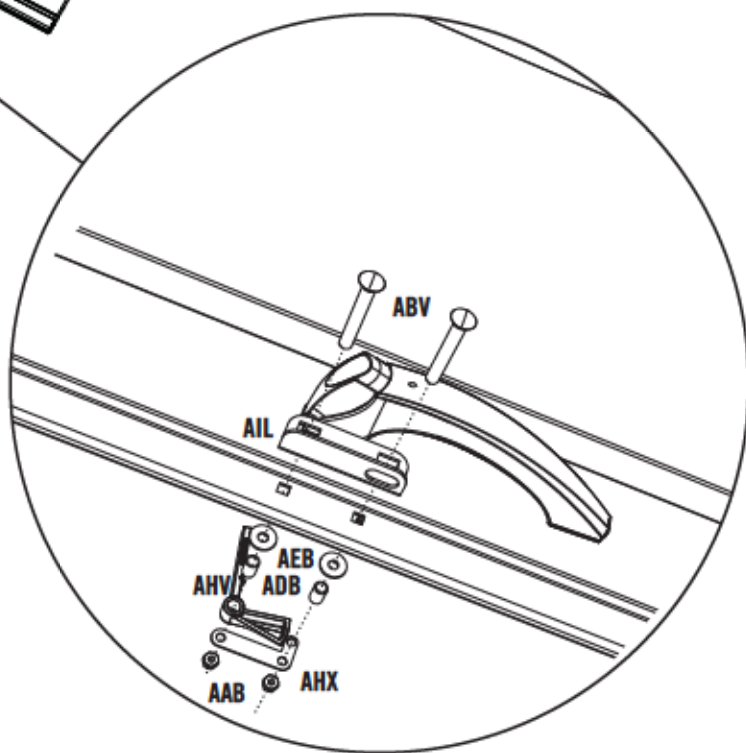
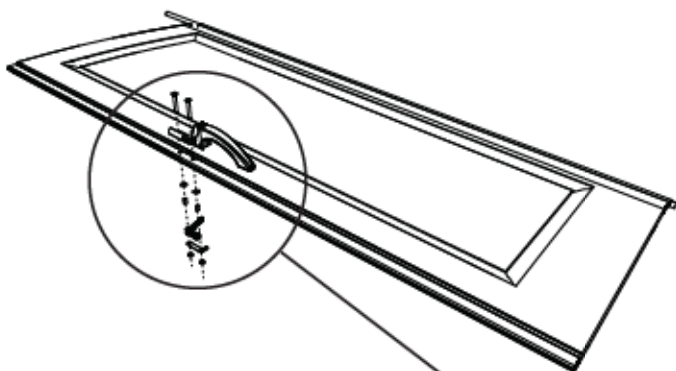



ADZ (x155)



DTV (x2)



ADX (x24)



AHP (x2)



BHJ (x2)

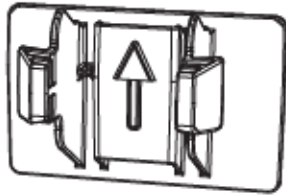

AXX (x4)

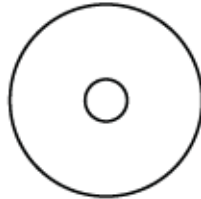

AED (x24)



AEE (x2)



CXK (x2)



Metal Pieces / Piezas de metal / Pièces en métal



AFL (x8)

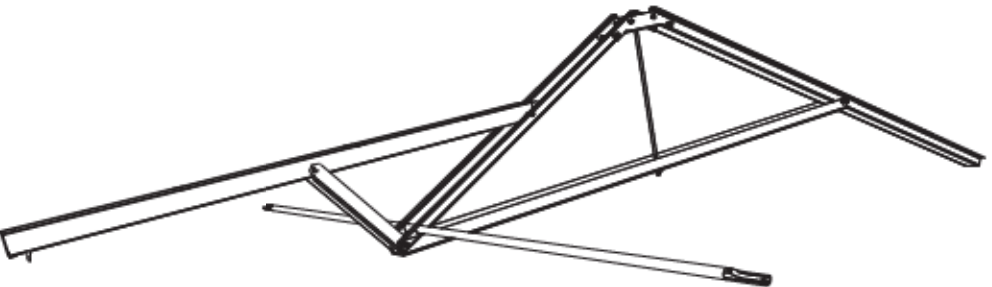
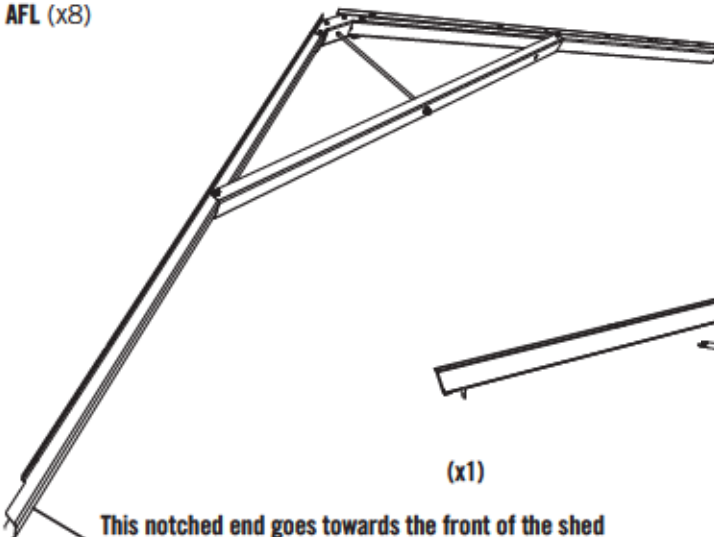

(x1)

(x2)

This notched end goes towards the front of the shed
 Este extremo muescado va hacia la parte delantera del cobertizo
 Cette extrémité encochée va vers la partie avant de l'abri



Plastic Pieces / Piezas de plástico / Pièces en plastique

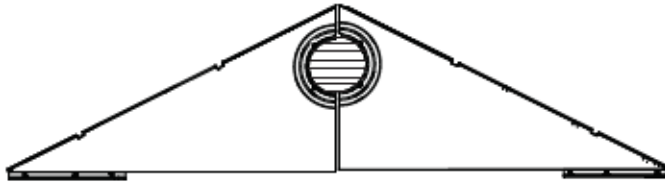

(x2)



(x1)

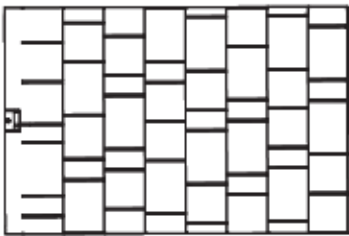

AGQ (x4)

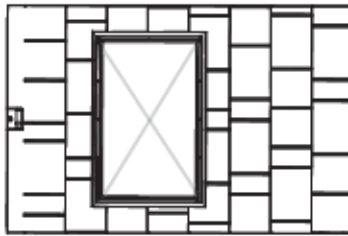

(x2)

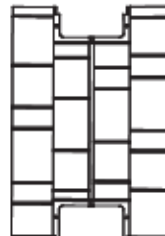

AFY (x3)

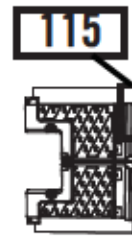

AGG (x1)



AFW (x1)



(x1)



(x1)

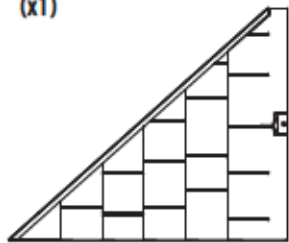

BDR (x1)

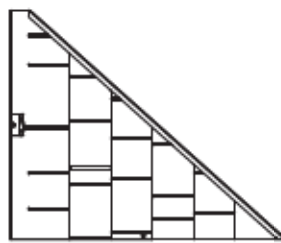

BDS (x1)



DRA (x1)



AHC (x4)



DRB (x1)



3/8" (9,5 mm)





9

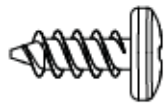

ADZ (x14)



9.1

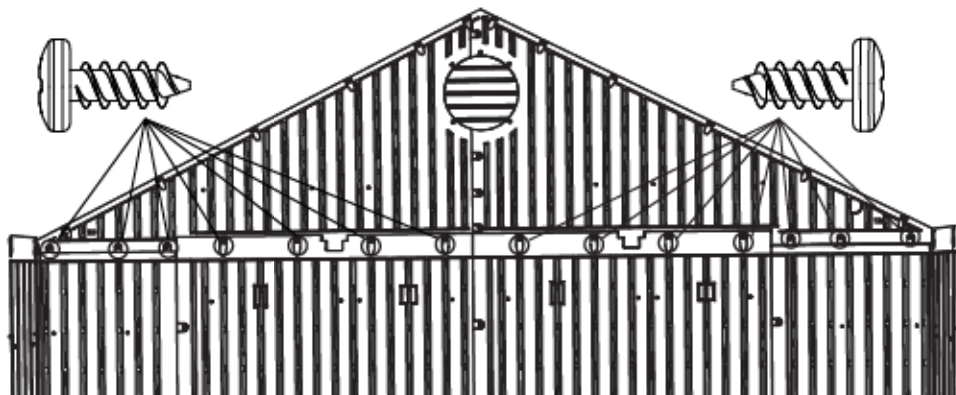

9.2

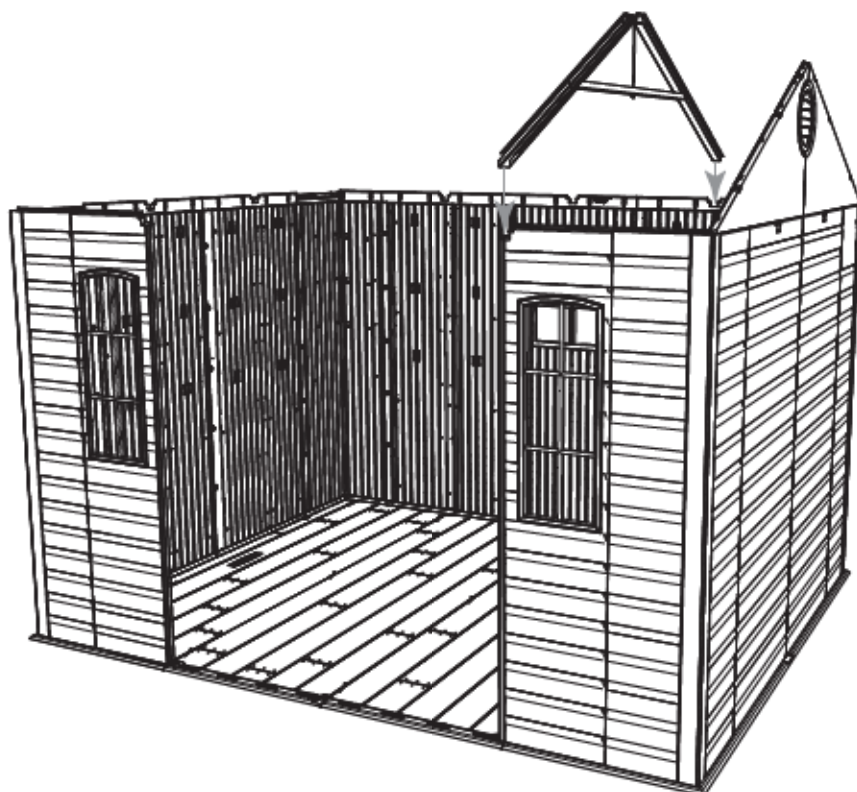



9



9.3

• Set the **Roof Panel (AHB)** down onto the Wall Panel, Gable, and Truss. The groove at the bottom of the Roof Panel sets over the top of the Wall Panel. Ensure the alignment nub fits into the notch in the Truss.

• Coloque el **Panel de tejado (AHB)** en el Panel de pared, el Faldón, y el Armazón. Coloque la ranura a lo largo del borde inferior del Panel de tejado sobre la parte superior del Panel de pared. Encaje el bulto de alineamiento en la muesca en el Armazón.

• Mettez le **Panneau de toit (AHB)** dans le Panneau mural, le Toit à pignon, et la Ferme. Mettez la rainure au bord inférieur du Panneau de toit sur la partie supérieure du Panneau mural. Mettez la petite bosse d'alignement dans l'encoche de la Ferme.

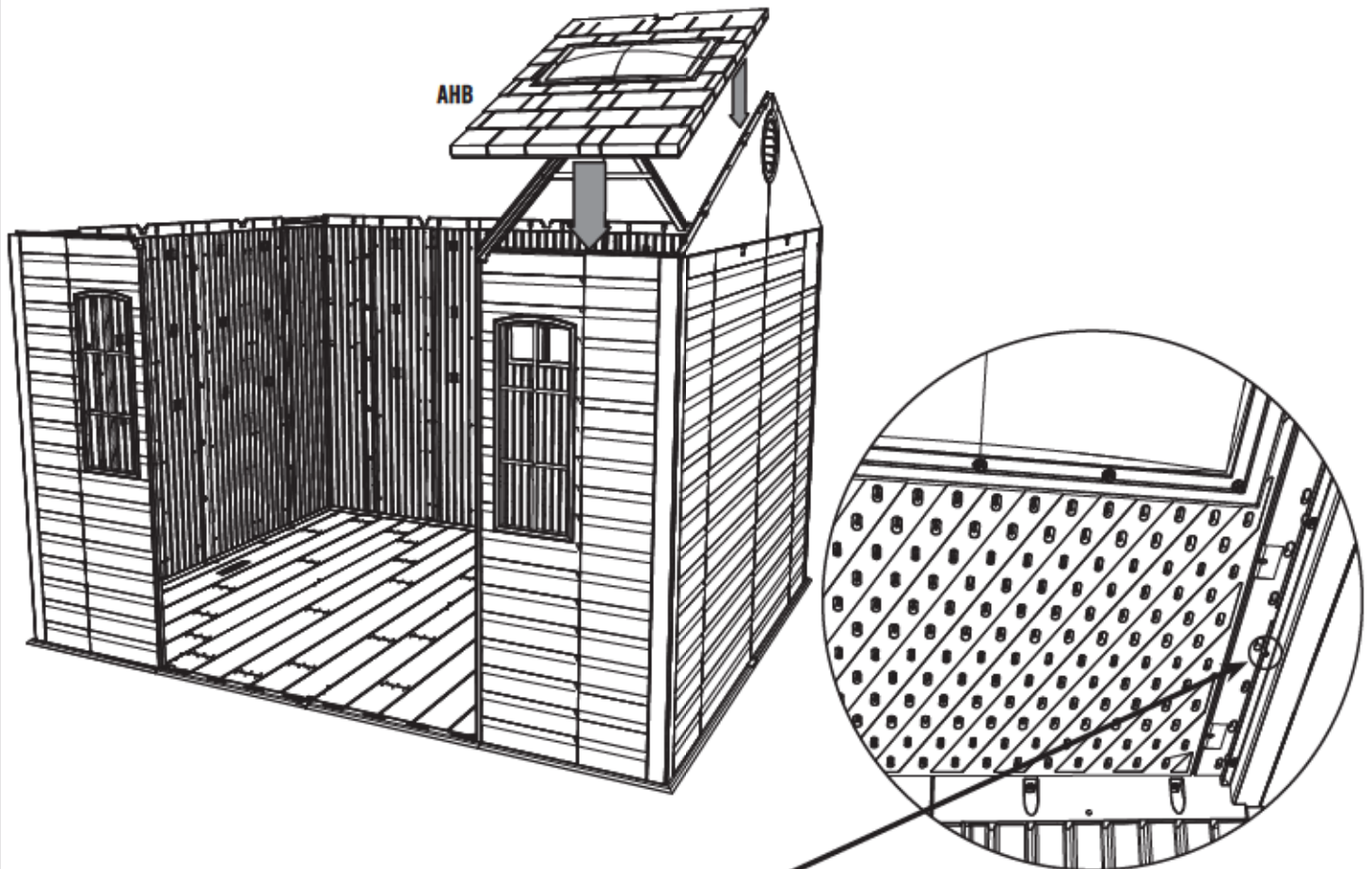

Alignment nub
Bulto de alineamiento
Petite bosse d'alignement



9

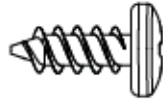

ADZ (x12)



9.4

• Align the four holes in the Wall Panel with those at the bottom of the Roof Panel, and insert four (4) **Screws (ADZ)** to secure the Panel in place. Then, insert the first **Screw (ADZ)** into the Gable and the Truss.

• Alinee los cuatro agujeros en el Panel de pared con los al borde inferior del Panel de tejado, e introduzca cuatro (4) **Tornillos (ADZ)** para sujetarlo en su lugar.

• Alignez les quatre trous dans le Panneau mural avec ceux au bord inférieur du Panneau de toit, et insérez quatre (4) **Vis (ADZ)** pour attacher le Panneau en place.

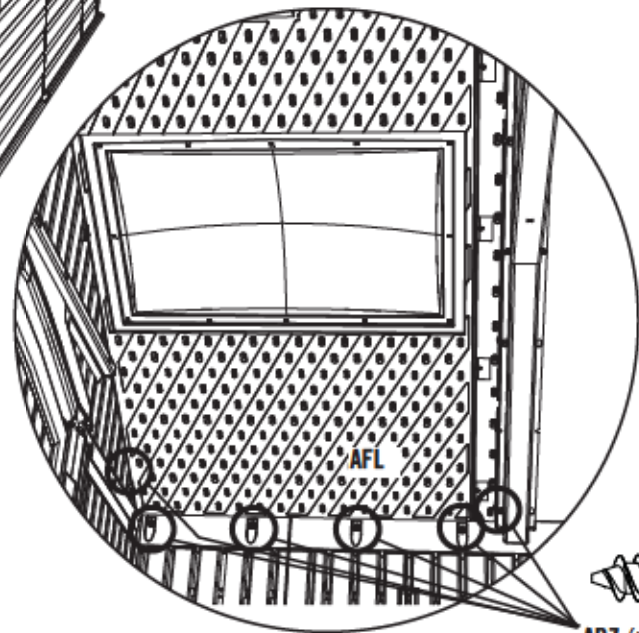
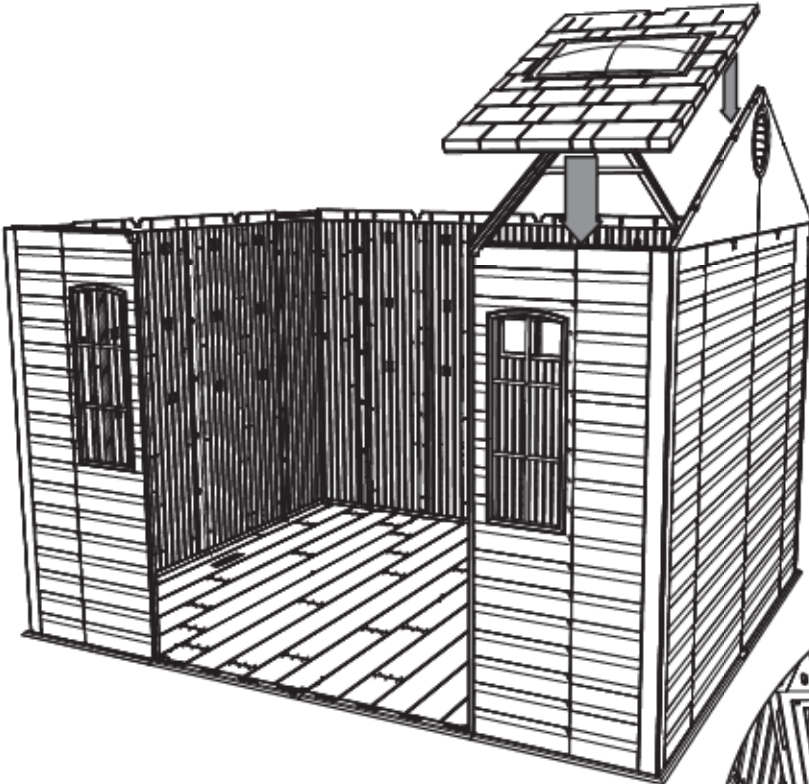

ADZ (x6)





9

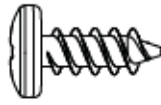

ADZ (x6)



AFL (x1)



9.5

• Now insert the first **Roof Support (AFL)** into the notches in the Gable and between the Truss and the Roof Panel as shown. Then, insert three (3) more **Screws (ADZ)** at the locations shown.

• Ahora, inserte el primer **Soporte de tejado (AFL)** en las muescas en el Faldón y entre el Armazón y el Panel de tejado como se muestra. Entonces, introduzca tres (3) **Tornillos (ADZ)** más a las ubicaciones ilustradas.

• Maintenant, mettez le premier **Support de toit (AFL)** dans les encoches dans le Toit à pignon et entre le Panneau de toit et la Ferme comme illustré. Ensuite, insérez trois (3) **Vis (ADZ)** aux emplacements illustrés.

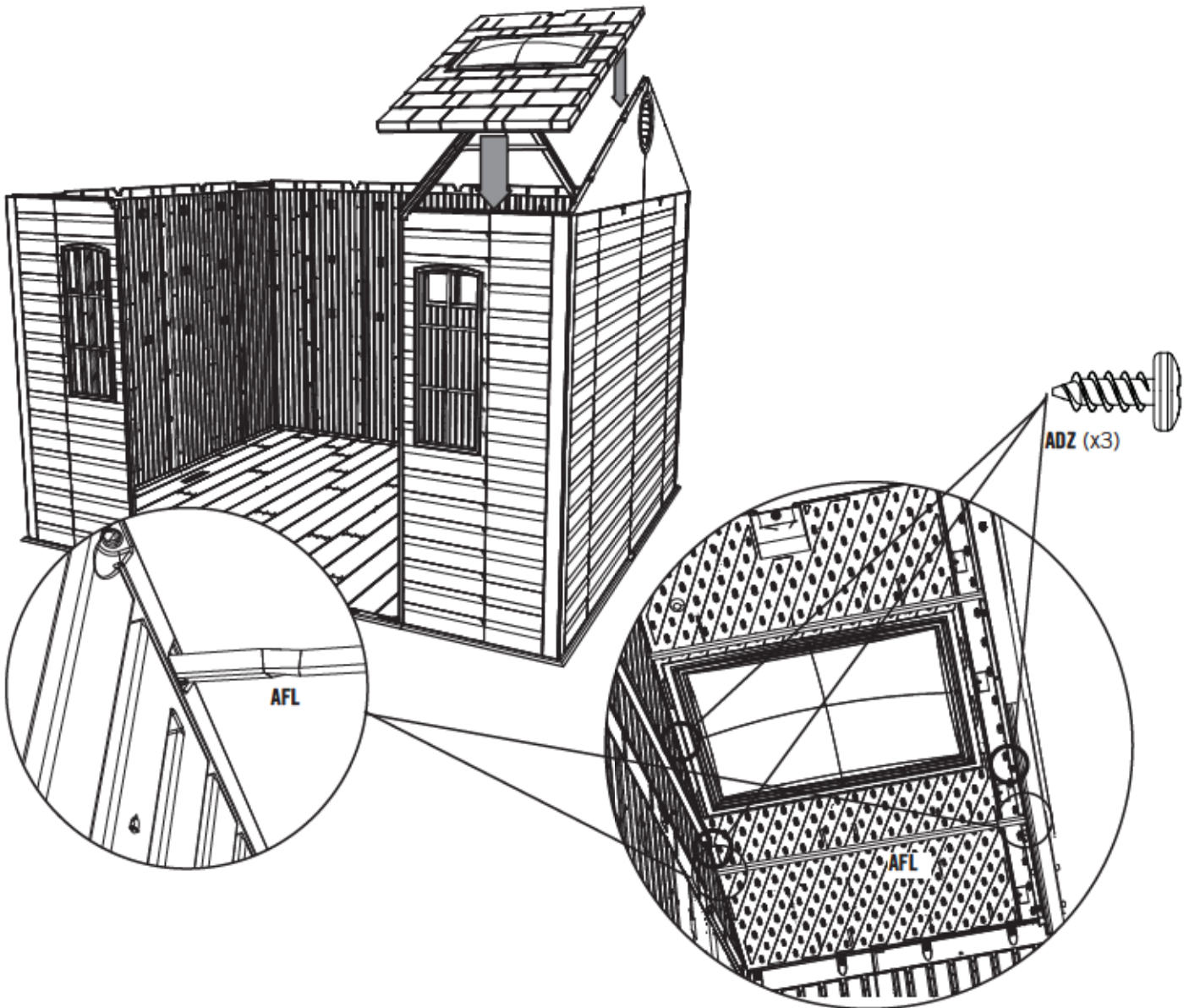

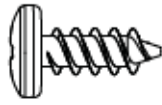

ADZ (x4)



AFL (x2)



9.6

• Now insert the second **Roof Support (AFL)** into the notches in the Gable and between the Truss and the Roof Panel as shown. Then, insert the last two (2) **Screws (ADZ)** at the locations shown.

• Ahora, inserte el segundo **Soporte de tejado (AFL)** en las muescas en el Faldón y entre el Armazón y el Panel de tejado como se muestra. Entonces, introduzca los dos (2) últimos **Tornillos (ADZ)** a las ubicaciones ilustradas.

• Maintenant, mettez le deuxième **Support de toit (AFL)** dans les encoches dans le Toit à pignon et entre le Panneau de toit et la Ferme comme illustré. Ensuite, insérez les dernières deux (2) **Vis (ADZ)** aux emplacements illustrés.

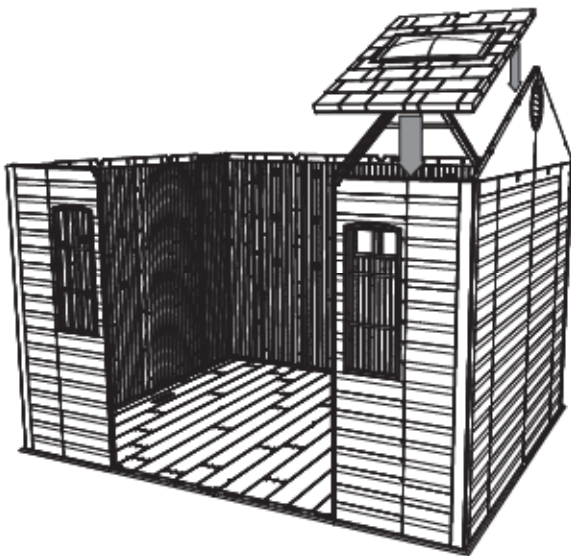

AFL (x1)

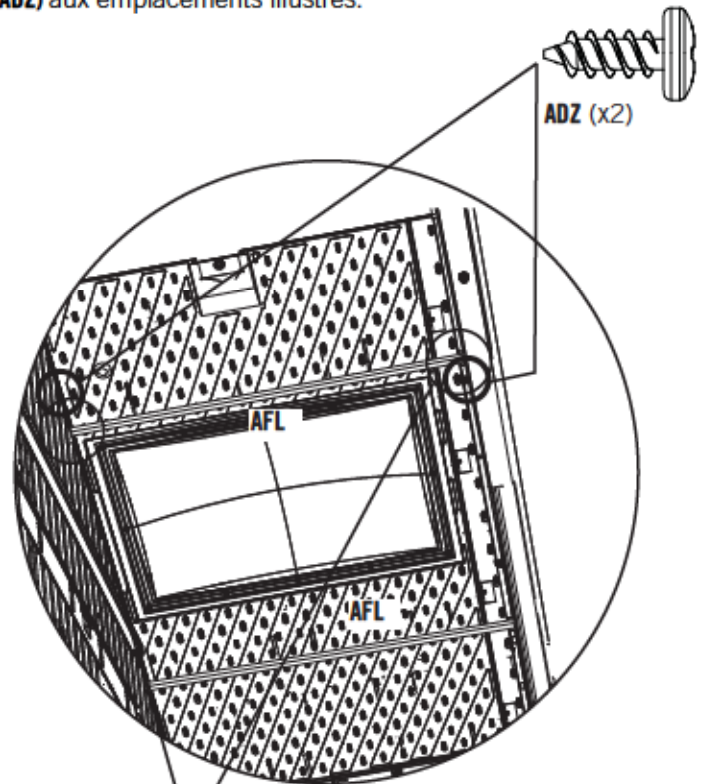

ADZ (x2)

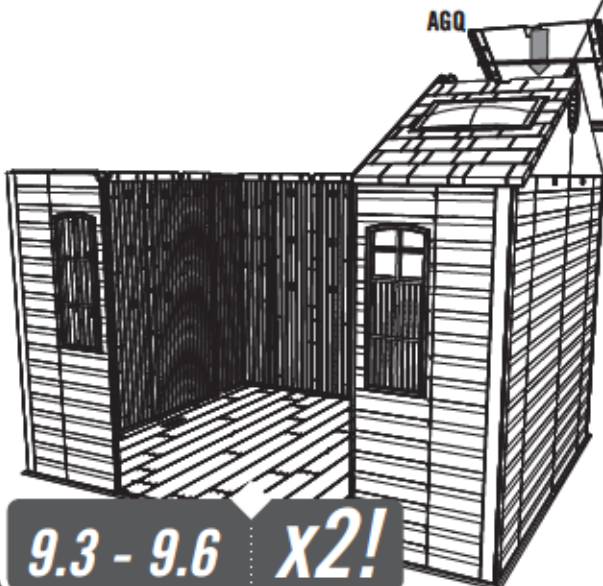

AGQ

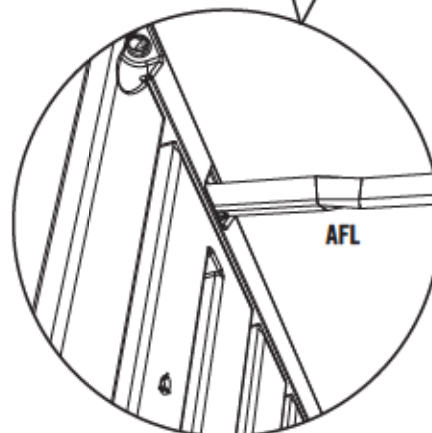

AFL

9.3 - 9.6 x2!



9

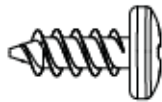

ADZ (x36)



AFL (x3)

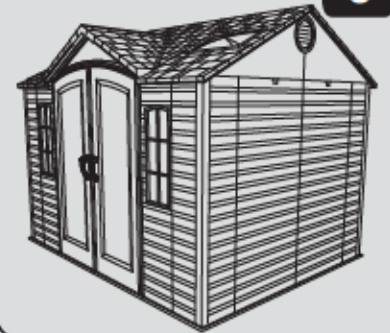

9.7

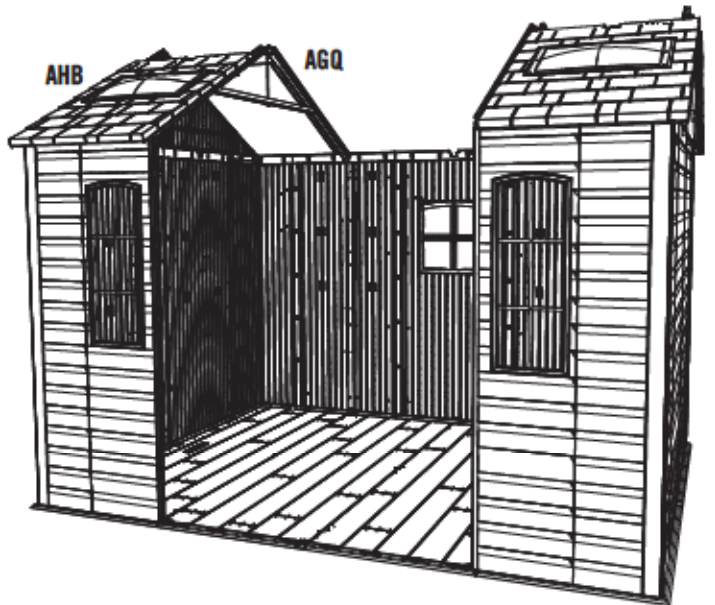
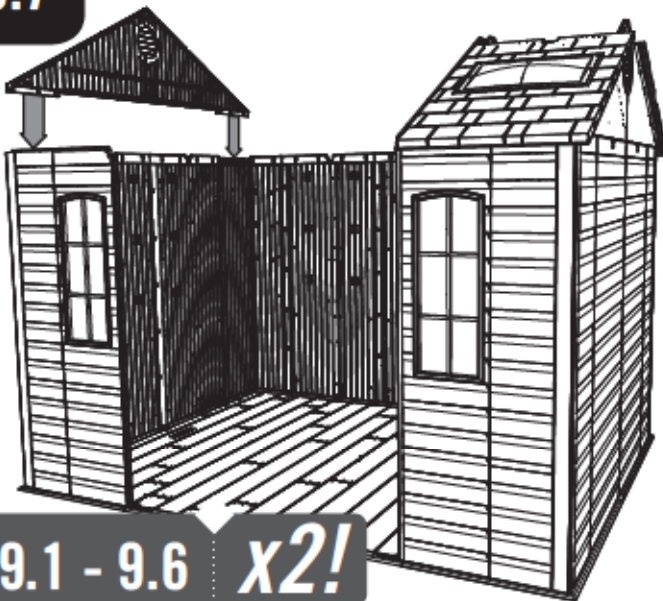

9.1 - 9.6 x2!

9.8

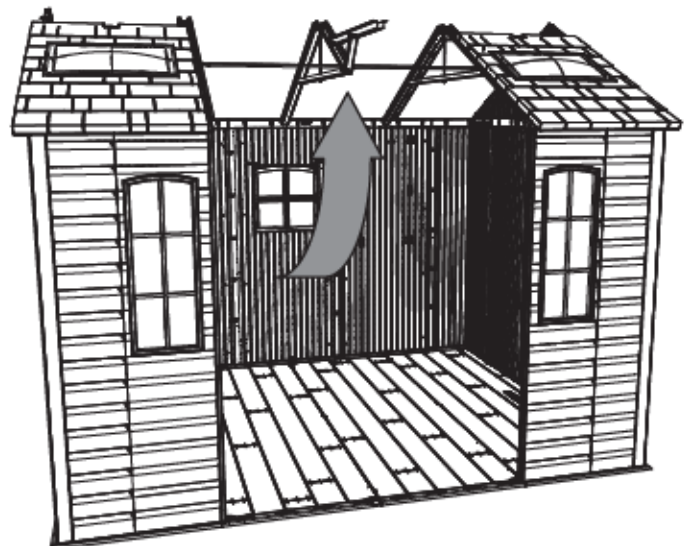
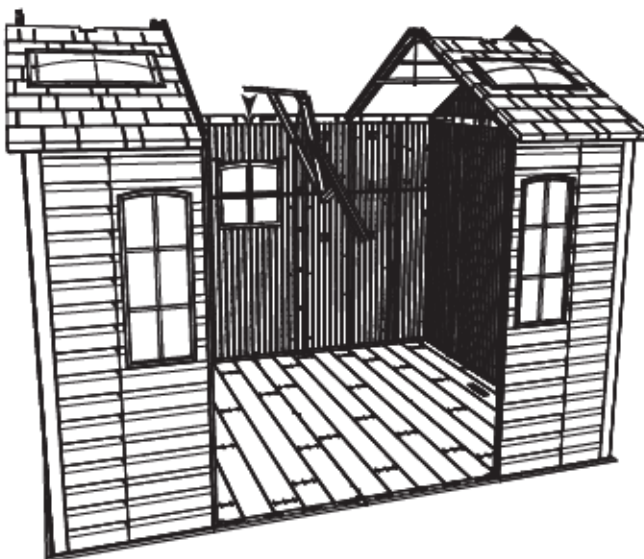



9



3/8"
(9,5 mm)



DTV (x2)



AEE (x2)



CXK (x2)



9.9

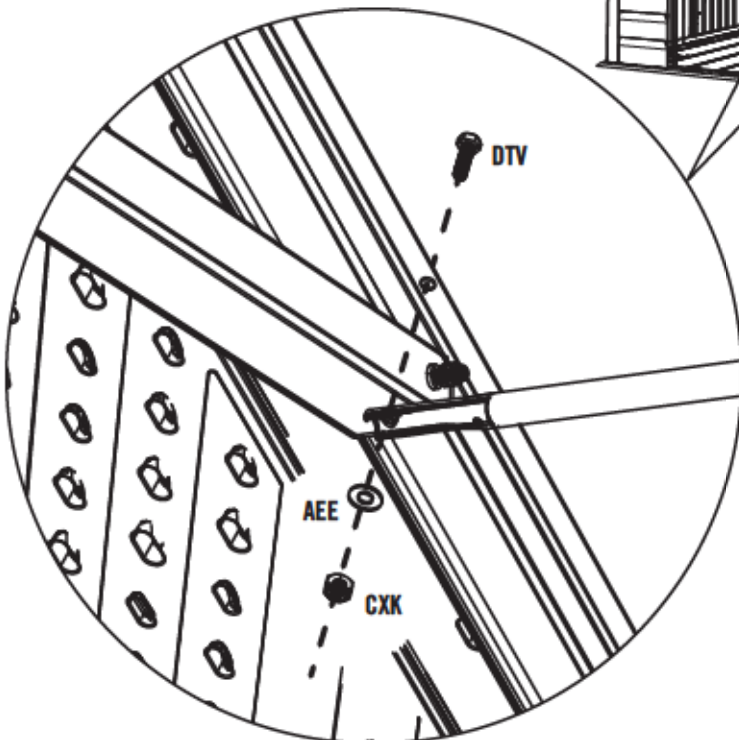
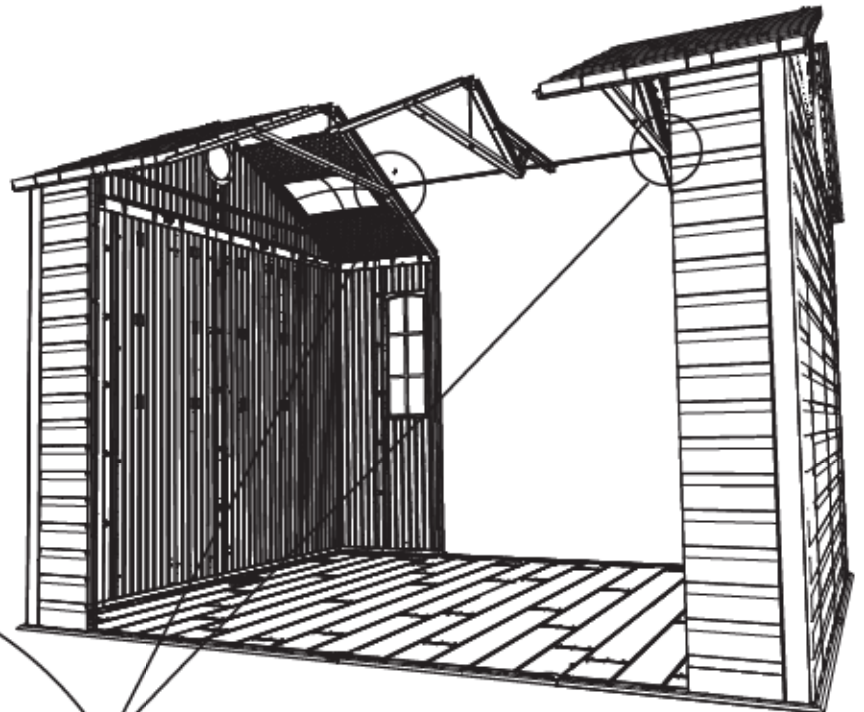

- Rear Wall Panels not shown in this image
- Los Paneles traseros no son ilustrados en este imagen
- Les Panneaux muraux arrières ne sont pas illustrés dans cet image



9



AHP (x2)



9.10

- Align the holes at the bottom of the Hinge Tubes with the slits in the Bushings.
- Alinee los agujeros en las partes inferiores de las Bisagras con las rendijas en los Casquillos.
- Alignez les trous dans les parties inférieures de les Charnières avec les fentes dans les Bagues.

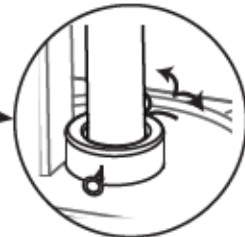
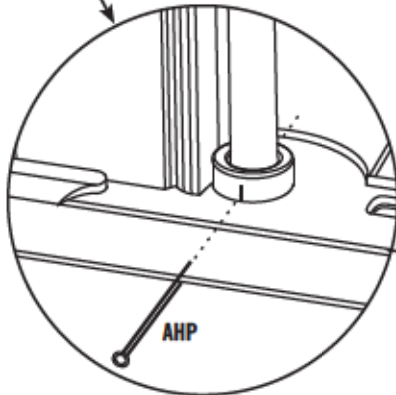
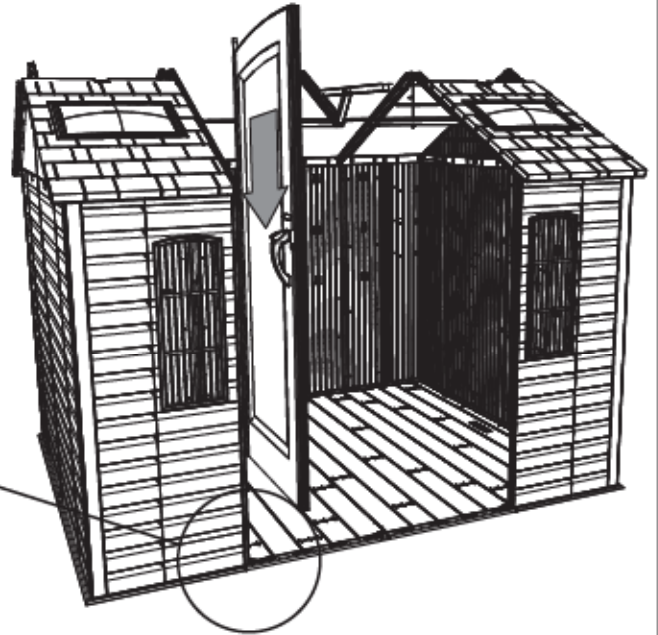
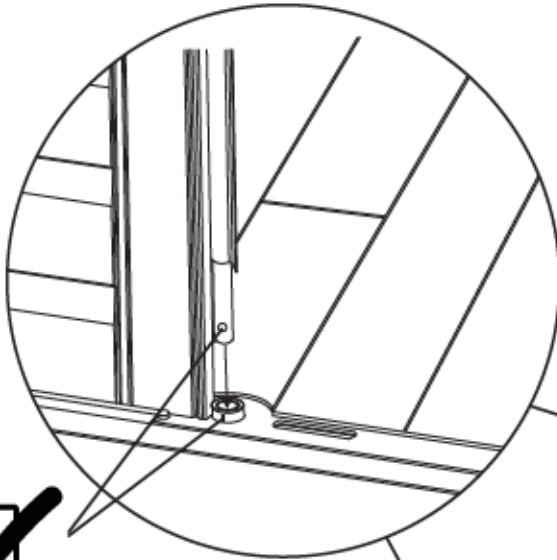

9.10 x2!



9

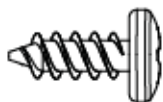

ADZ (x1)



9.11

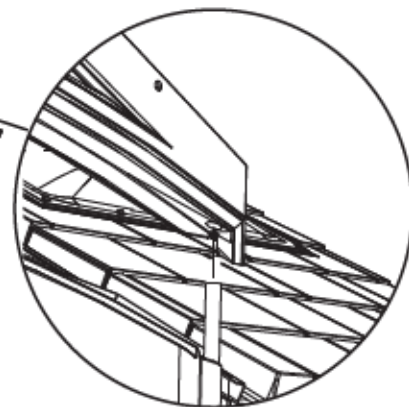
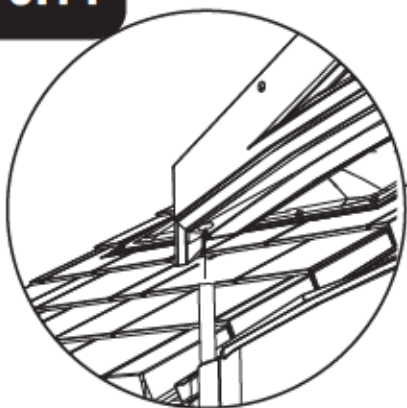

9.12

- Set the end of the Center Truss onto the notch in the Front Gable Panel as shown.
- Coloque el extremo del Armazón central en la muesca en la Fachada delantera como se muestra.
- Mettez l'extrémité de la Ferme centrale dans l'encoche dans la Toit à pignon avant comme illustré.

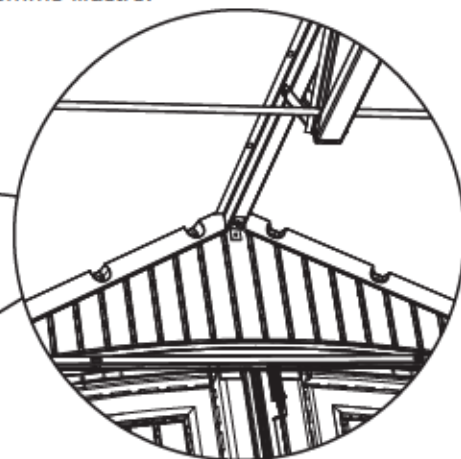

ADZ

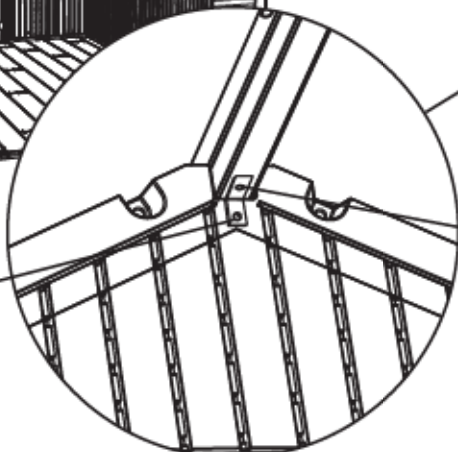

- Tighten this Nut and Bolt now.
- Apriete este Perno y la Tuerca ahora.
- Serrez ce Boulon et l'Écrou maintenant.



9



ADZ (x34)



AFL (x2)



9.13

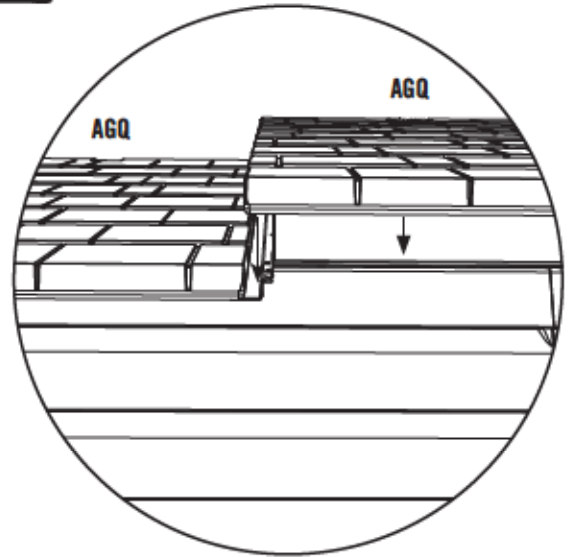
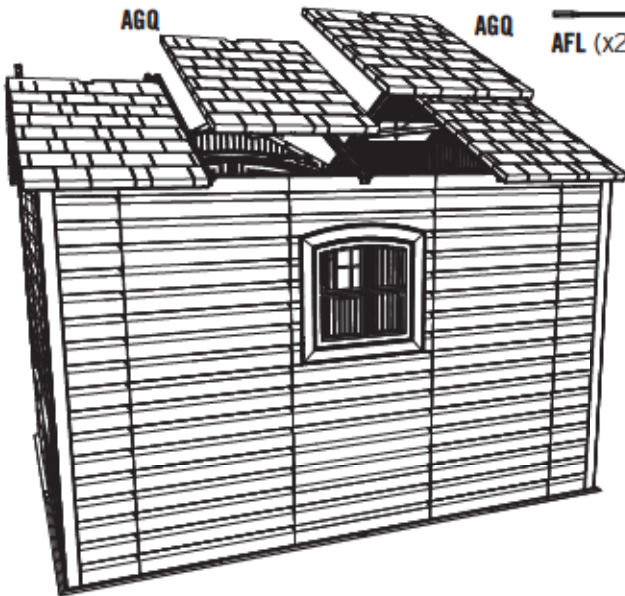

9.14

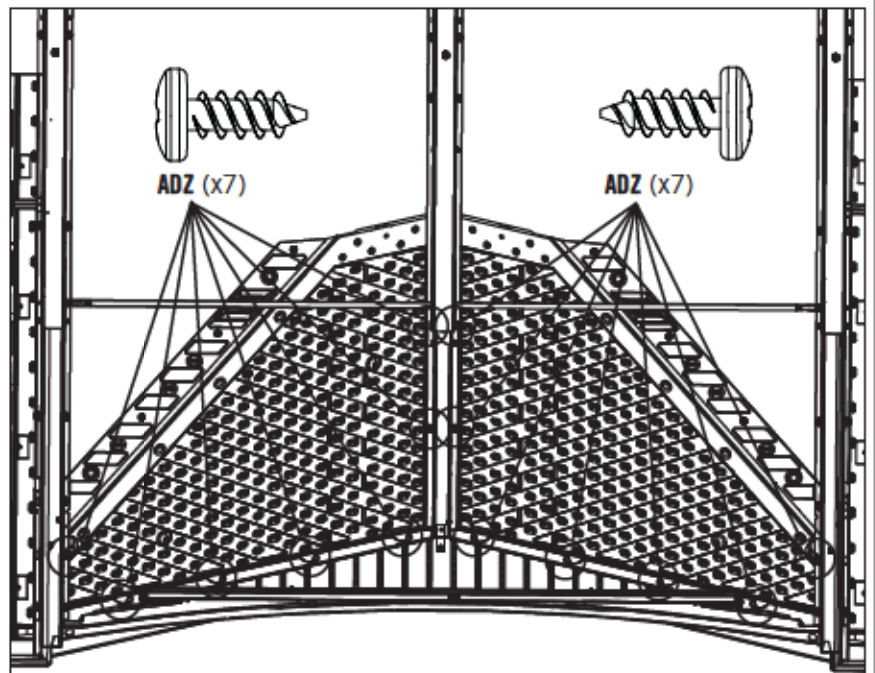

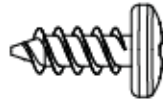

ADZ (x20)



9.15

• An adult must apply a downward pressure on **Panel (DRB)** while another inserts these **Screws (ADZ)**.

• Un adulto debe aplicar una presión de arriba en el **Panel (DRB)** mientras que introduzca estos **Tornillos (ADZ)**.

• Une adulte doit appliquer pression sur le **Panneau (DRB)** pendant que vous insérez ces **Vis (ADZ)**.



DRB

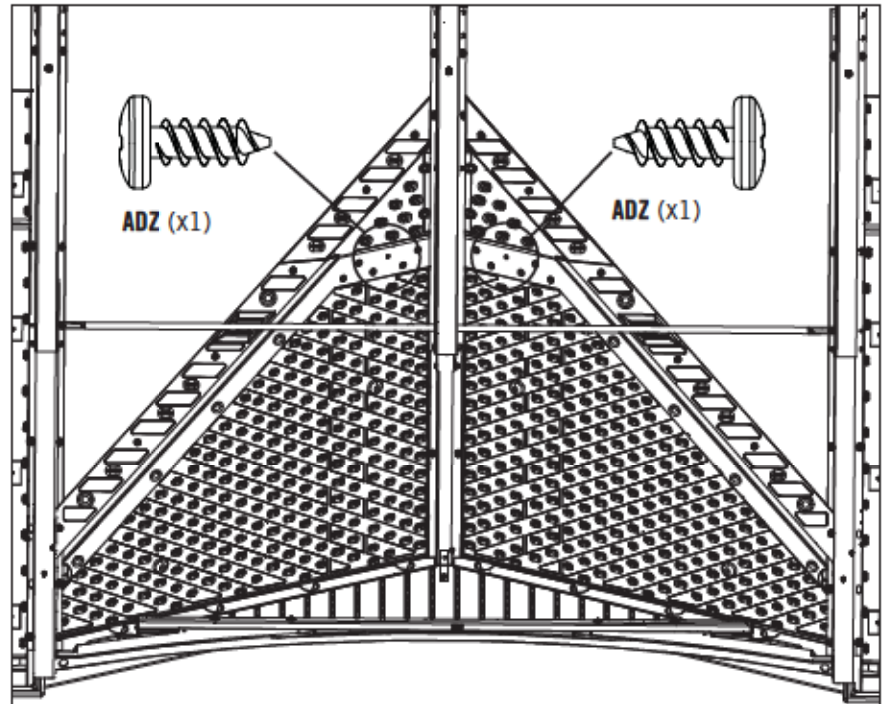

ADZ (x1)

ADZ (x1)

9.16

• An adult must apply a downward pressure on **Panels (BDS & BDR)** while another inserts these **Screws (ADZ)**.

• Un adulto debe aplicar una presión de arriba en los **Paneles (BDS & BDR)** mientras que introduzca estos **Tornillos (ADZ)**.

• Une adulte doit appliquer pression sur les **Panneaux (BDS & BDR)** pendant que vous insérez ces **Vis (ADZ)**.

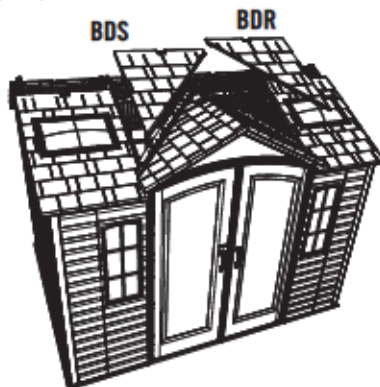

BDS

BDR

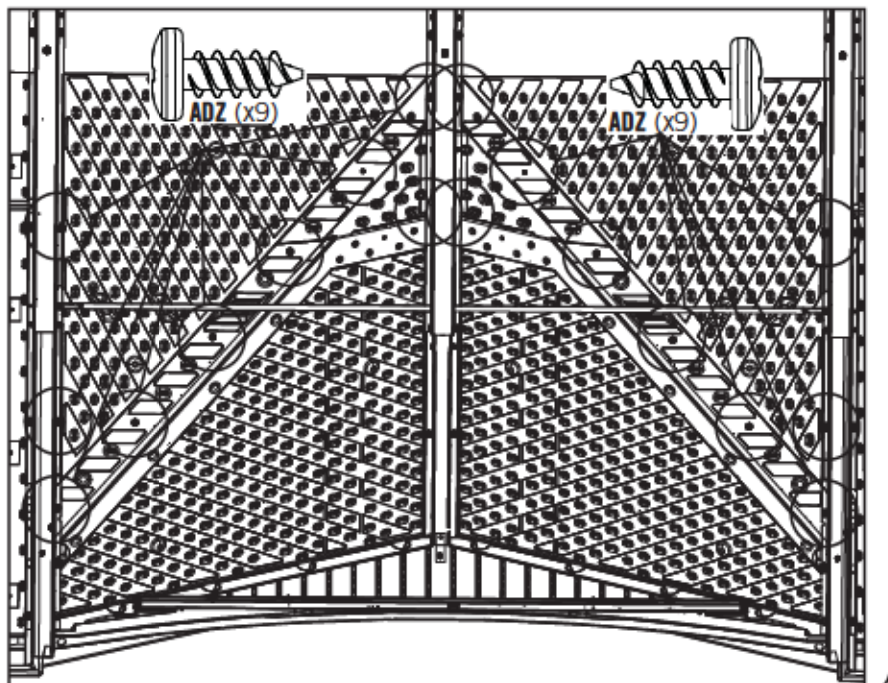

ADZ (x9)

ADZ (x9)



9



BHJ (x2)



9.17

- Use a electric screwdriver to Insert a **Self Tapping Screw (BHJ)** through the Gable and into the Door Hinge Tube at the location shown. **Repeat this step for the Right Door.**
- Utilice un taladro eléctrico para introducir un **Tornillo auto-roscante (BHJ)** a través la Fachada y dentro de la Bisagra a la ubicación ilustrada. **Repita este paso para la Puerta derecha.**
- Employez un perceuse électrique pour insérer une **Vis autotaraudeuse (BHJ)** à travers le Toit à pignon et dans la Charnière de la porte à l'emplacement illustré. **Répétez cette étape pour la Porte droite.**

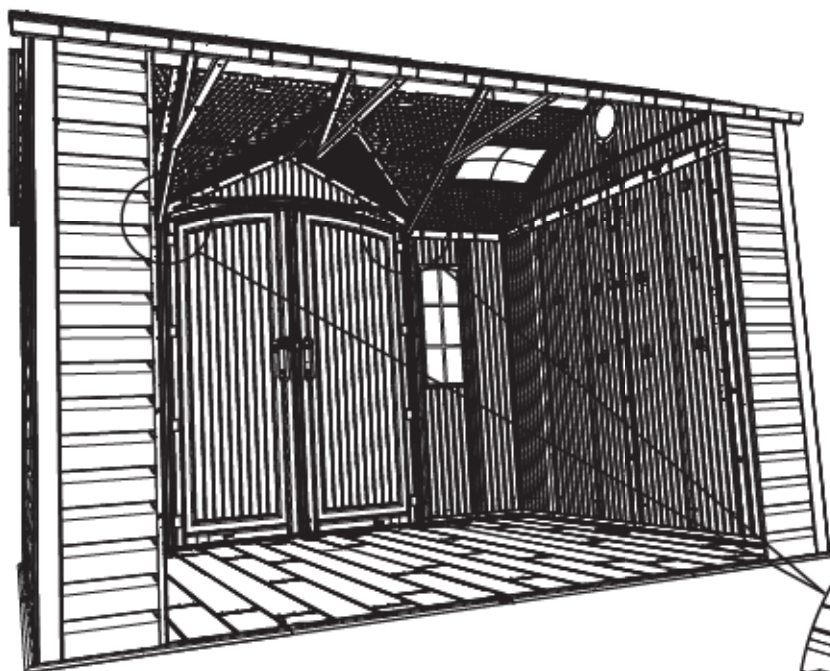



9

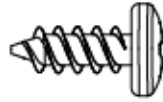

ADZ (x28)



9.18

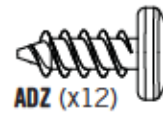
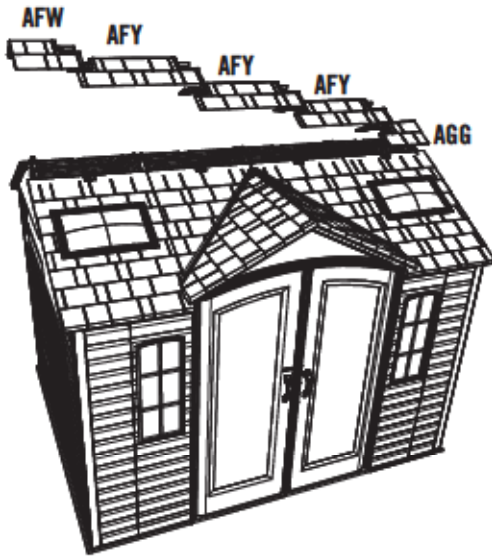

ADZ (x12)



ADZ (x8)

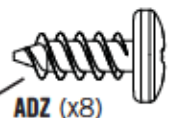
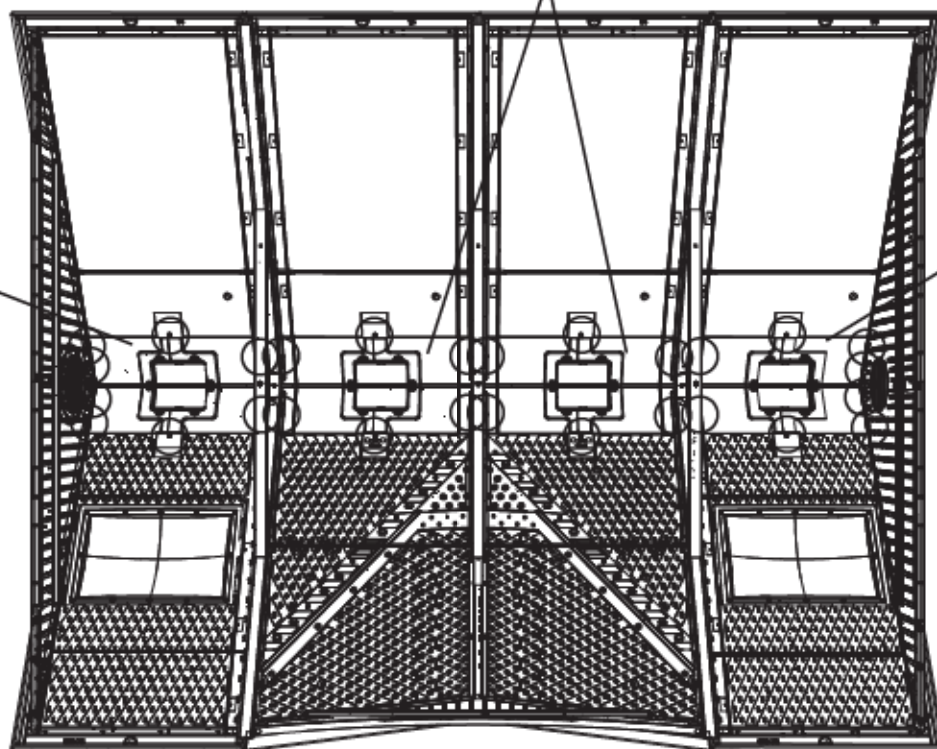

ADZ (x8)

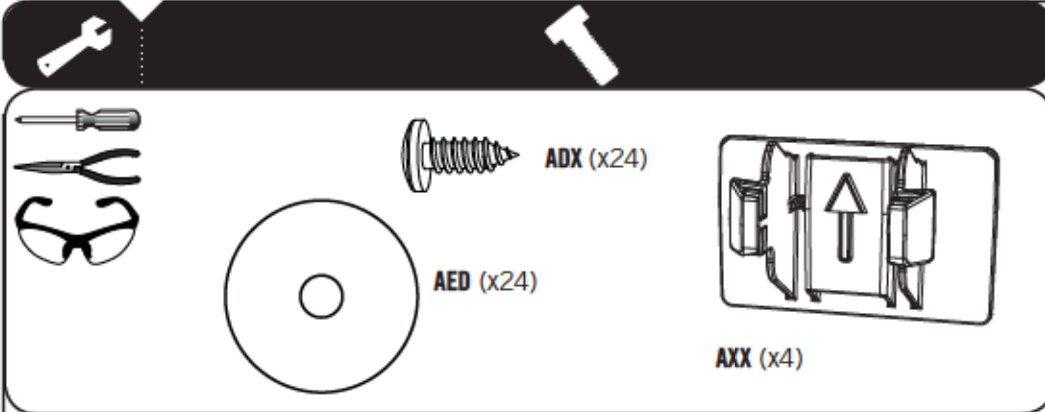

9.19



- Use a pair of pliers to pull down on the tab while inserting the Screws.
- Utilice unos alicates para tirar hacia abajo la lengüeta mientras que introduzca los Tornillos.
- Employez une pince pour tirer la languette vers le bas pendant que vous insérez les Vis.

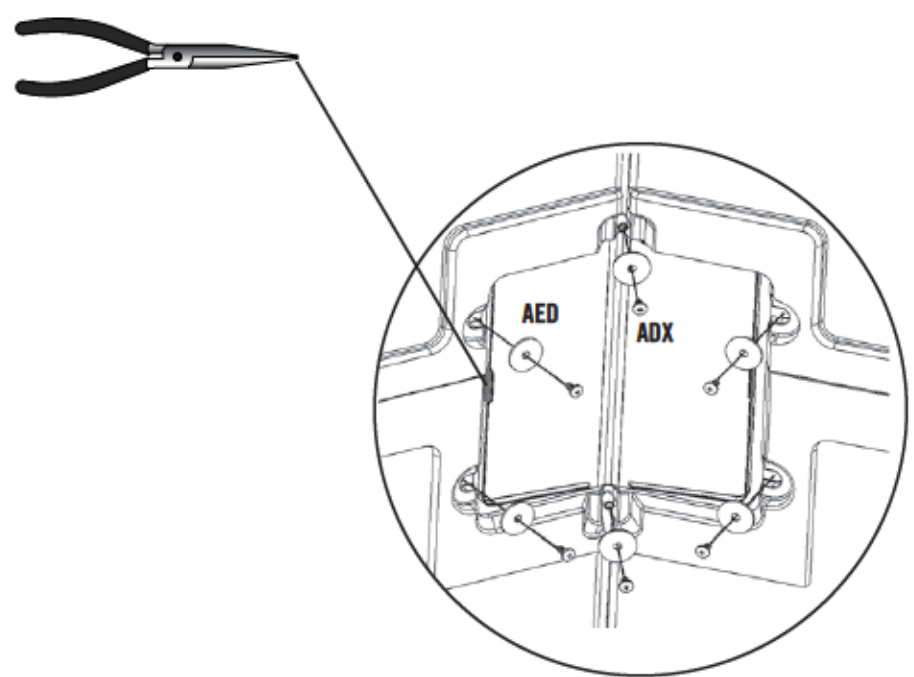
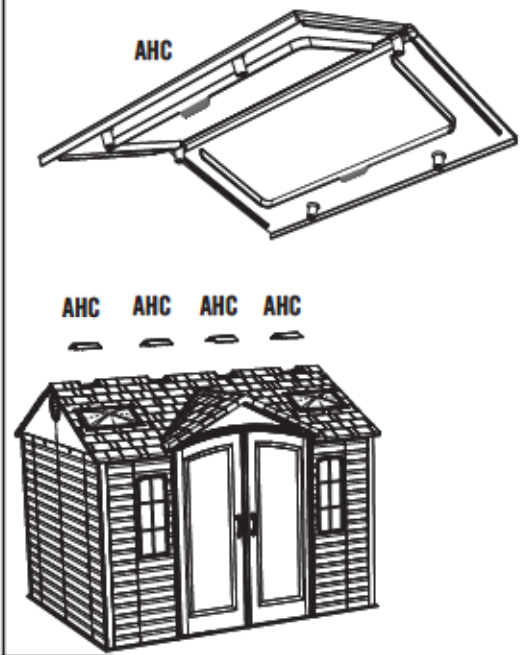

9.20

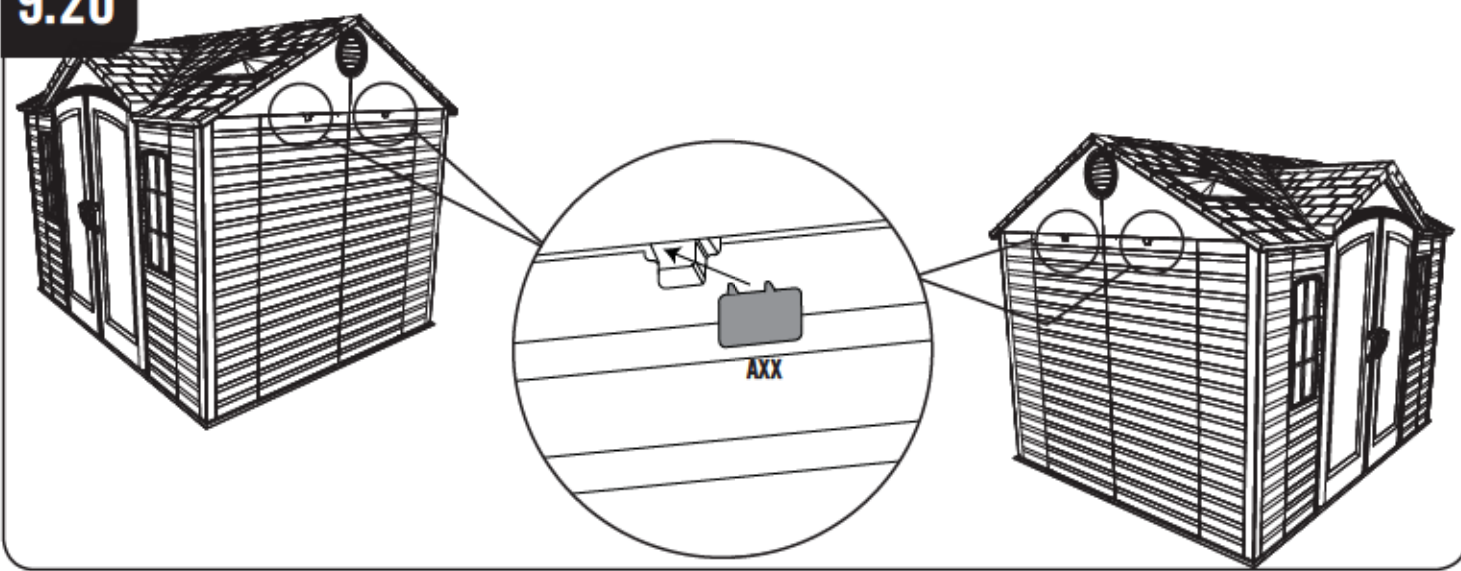



ADZ (x28)



AIY (x4)

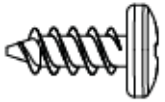

ADZ (x8)

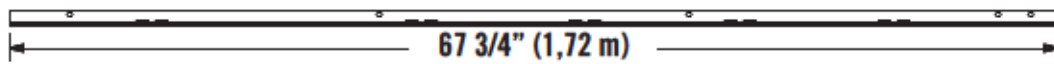
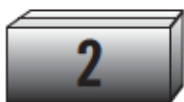

67 3/4" (1,72 m)

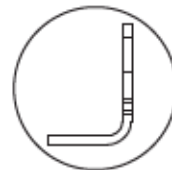

AFM (x4)

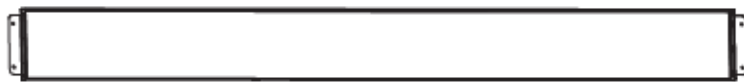

AFV (x2)



AFZ (x2)





10

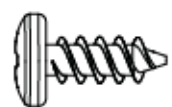

ADZ (x16)



AIY (x4)



10.1

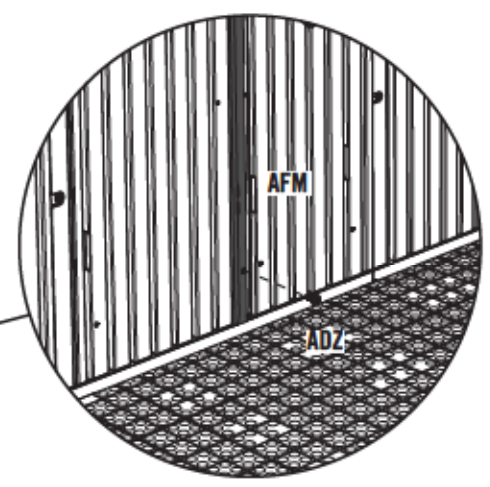
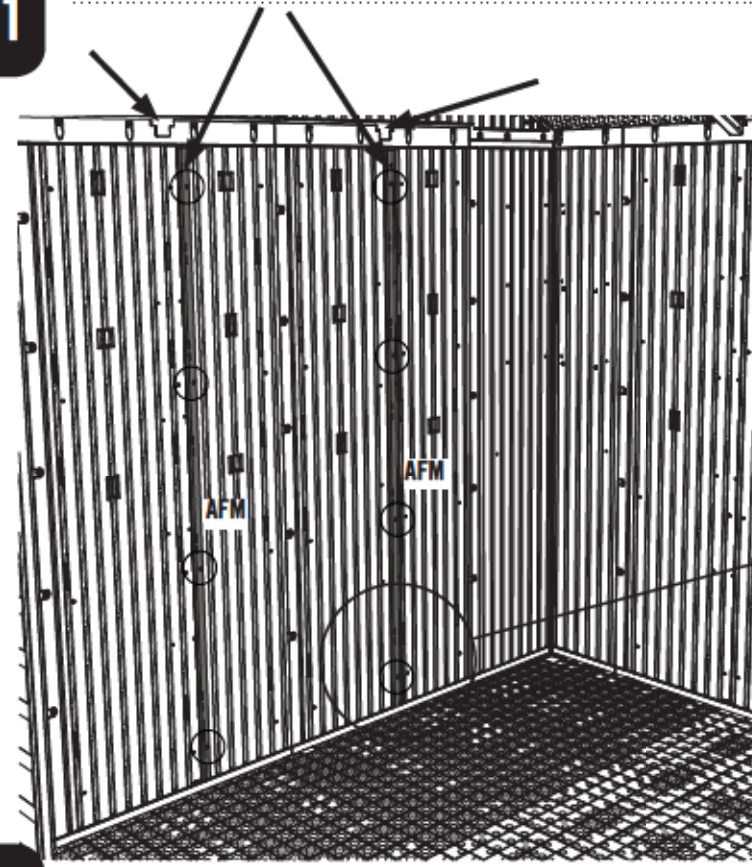

10.2

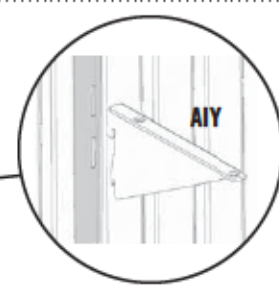
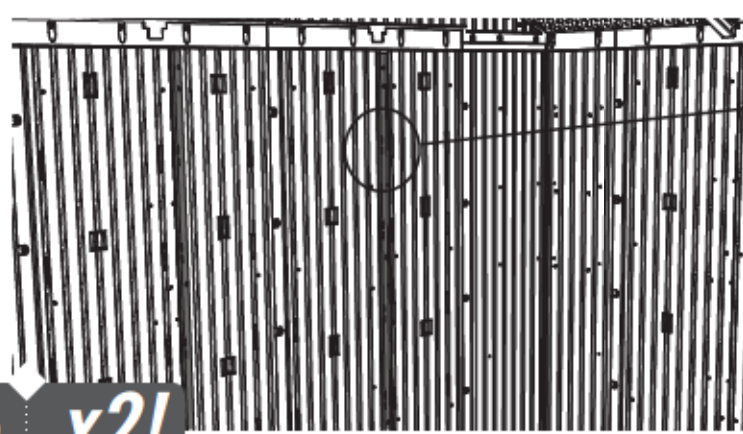

10.2 x2!



10

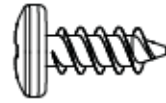

ADZ (x12)



10.3

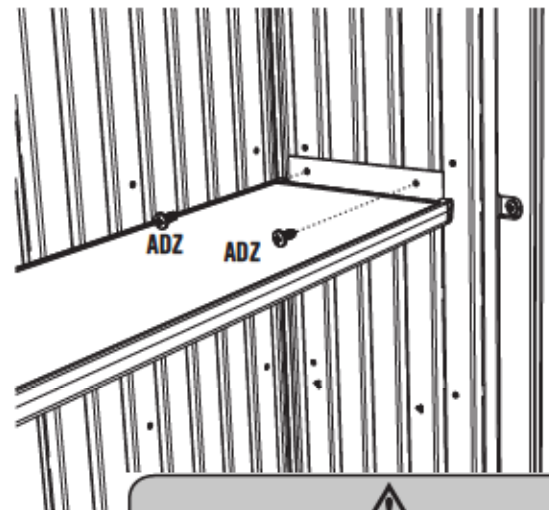
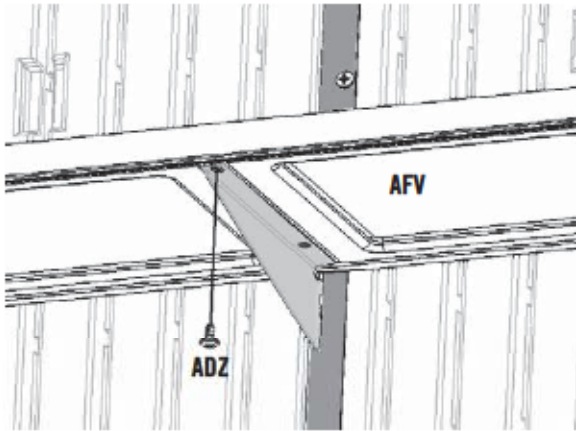



↓ 50 lb. (23 kg)



10.1-10.3 x2!

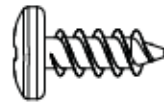

10



ADZ (x8)



10.4

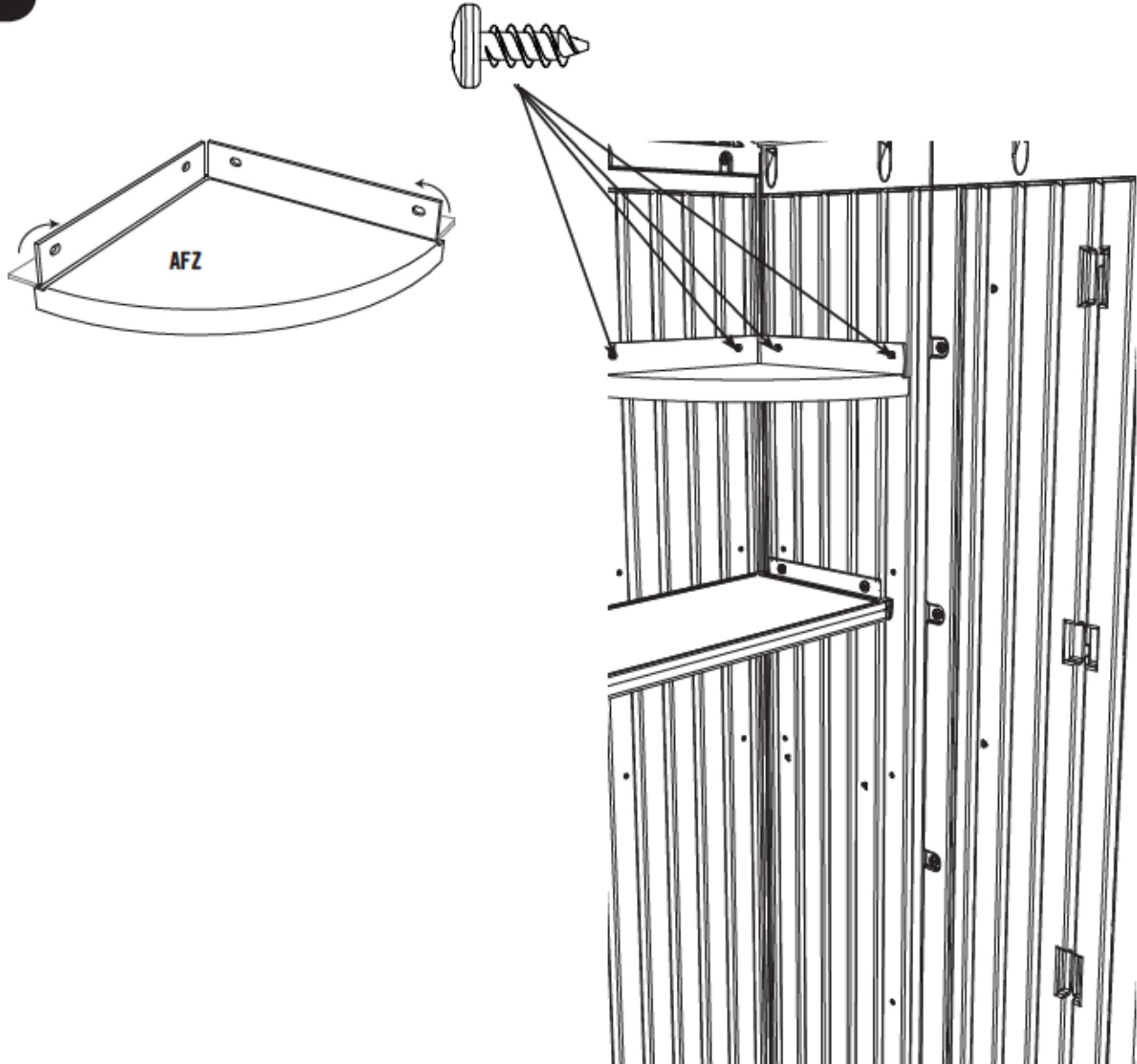

10.4 x2!



↓ 10 lb. (4.5 kg)

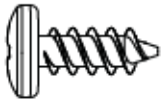

ADZ (x4)

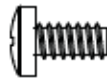

ADY (x1)



ADW (x28)

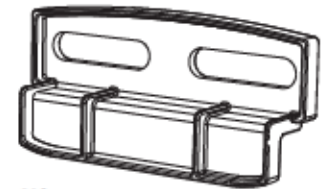

AIS (x2)



AHE (x1)



BDV (x2)





11

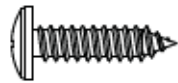

ADW (x28)



11.1

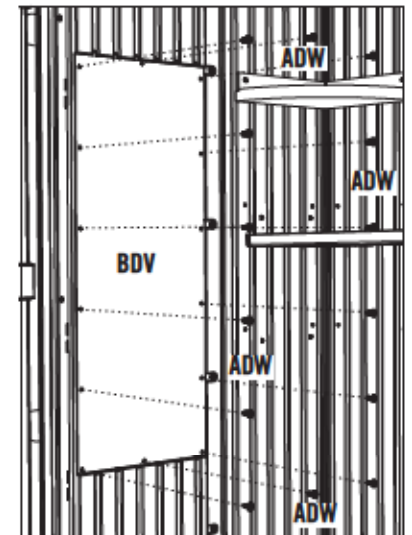
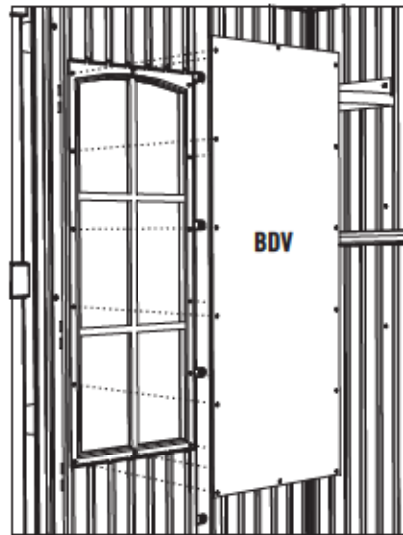
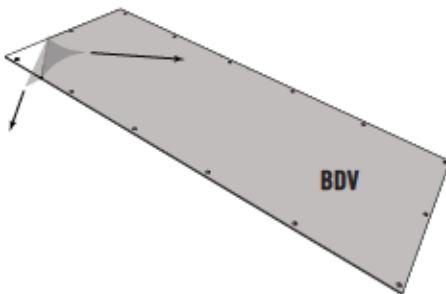

11.1 x2!

11.2

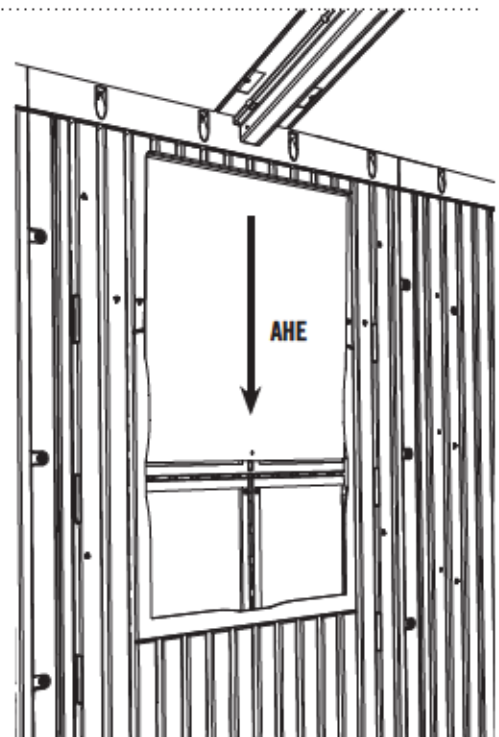
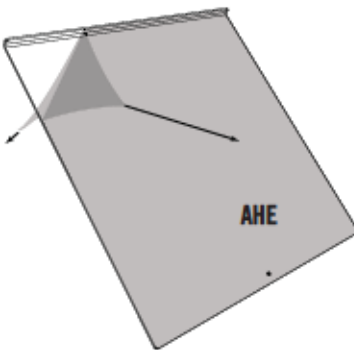



11

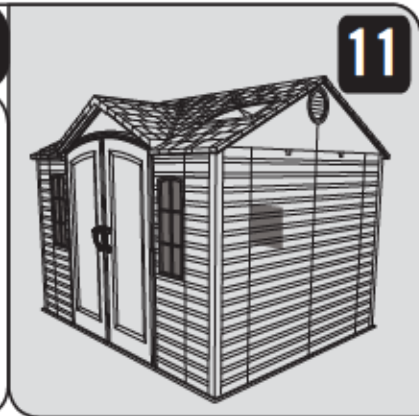
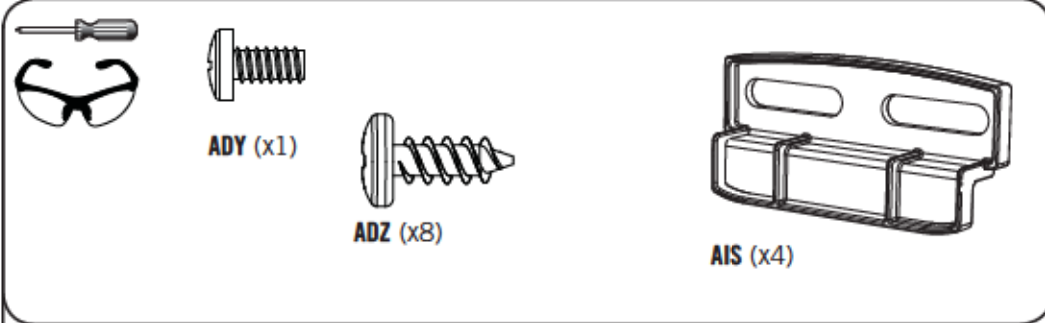

11.3

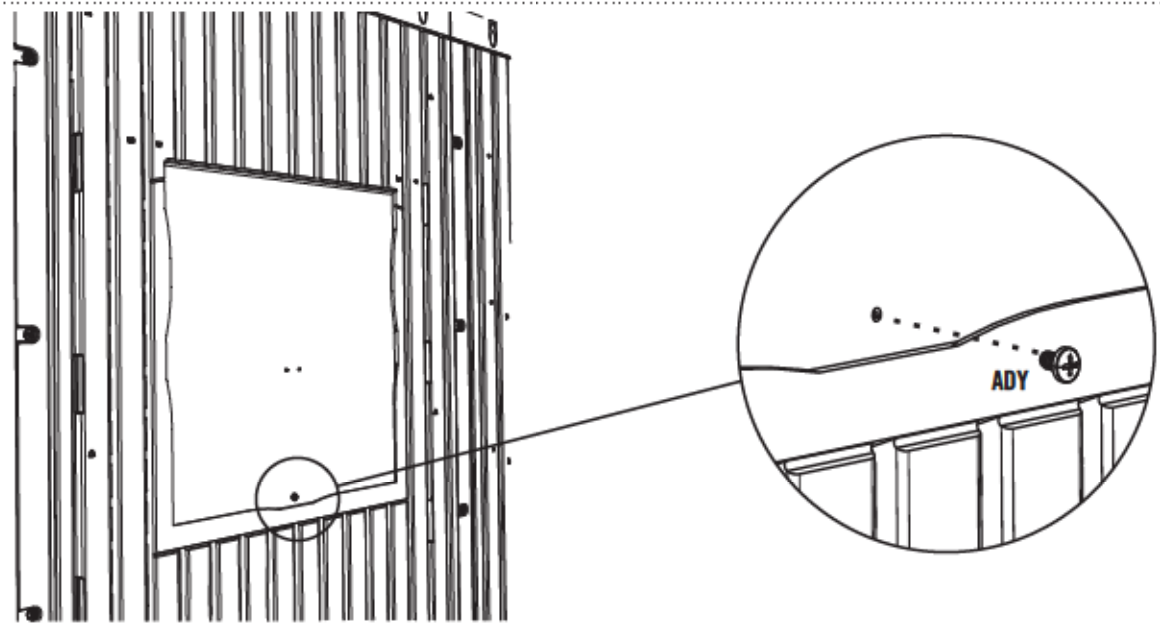

11.4

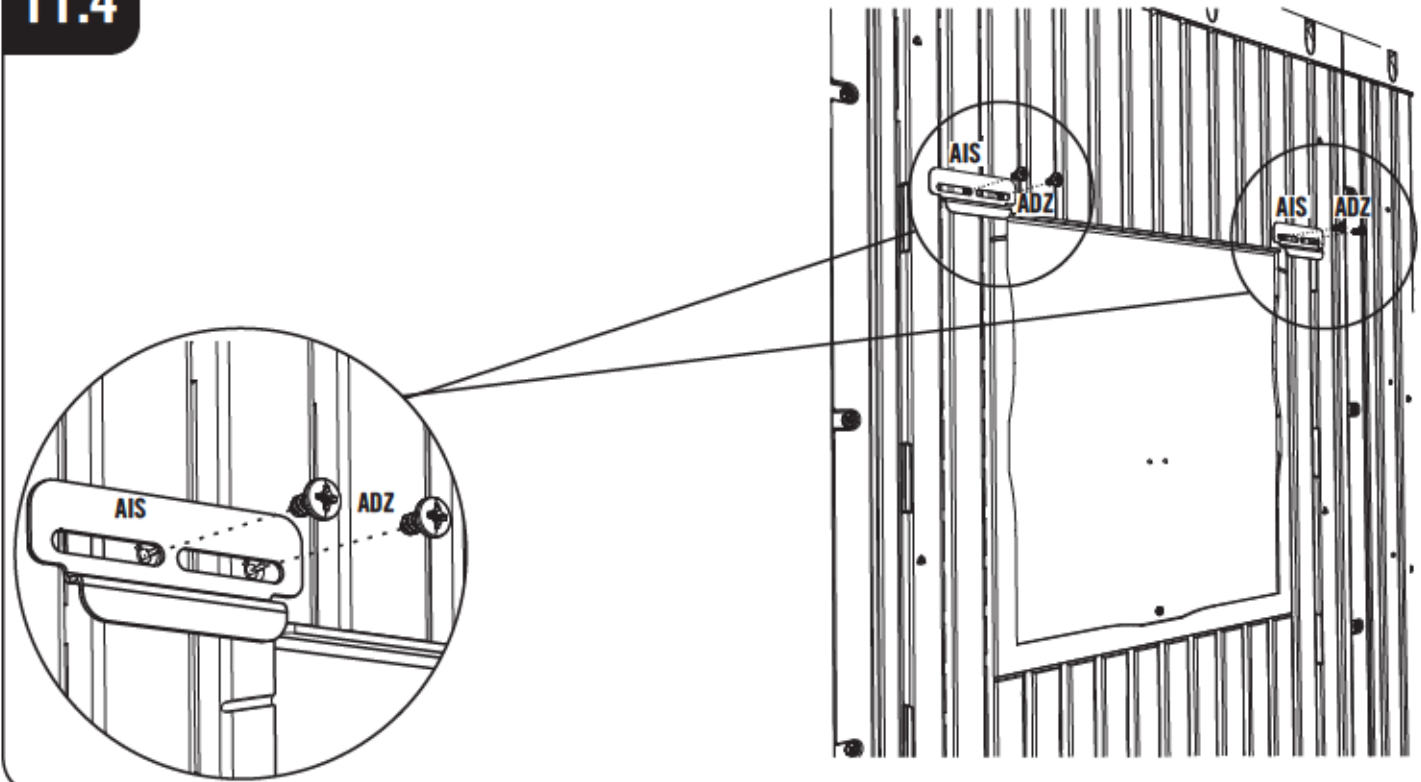



ADW (x10)

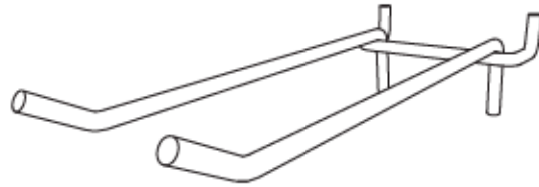

AIG (x1)

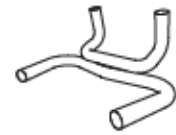

AJJ (x2)

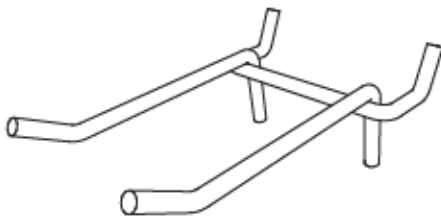

AIF (x1)



AIH (x3)



AII (x3)

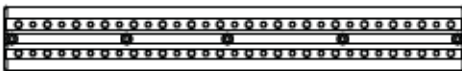

AFU (x1)





ADW (x10)

12



12.1

- Attach the **Pegboard Strip (AFU)** to a Wall Panel using five (5) **Screws (ADW)**. Avoid Corner Wall Panels and Window Wall Panels.

- Sujete el **Organizador de herramientas (AFU)** a un Panel de pared usando cinco (5) **Tornillos (ADW)**. Evite los Paneles angulares y los Paneles para la ventana.

- Attachez l'**Organiseur d'outils (AFU)** au Panneau mural à l'aide de cinq (5) **Vis (ADW)**. Évitez les Panneaux angulaires et les Panneaux pour la fenêtre.

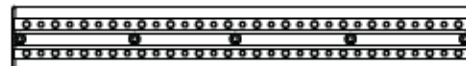

AFU

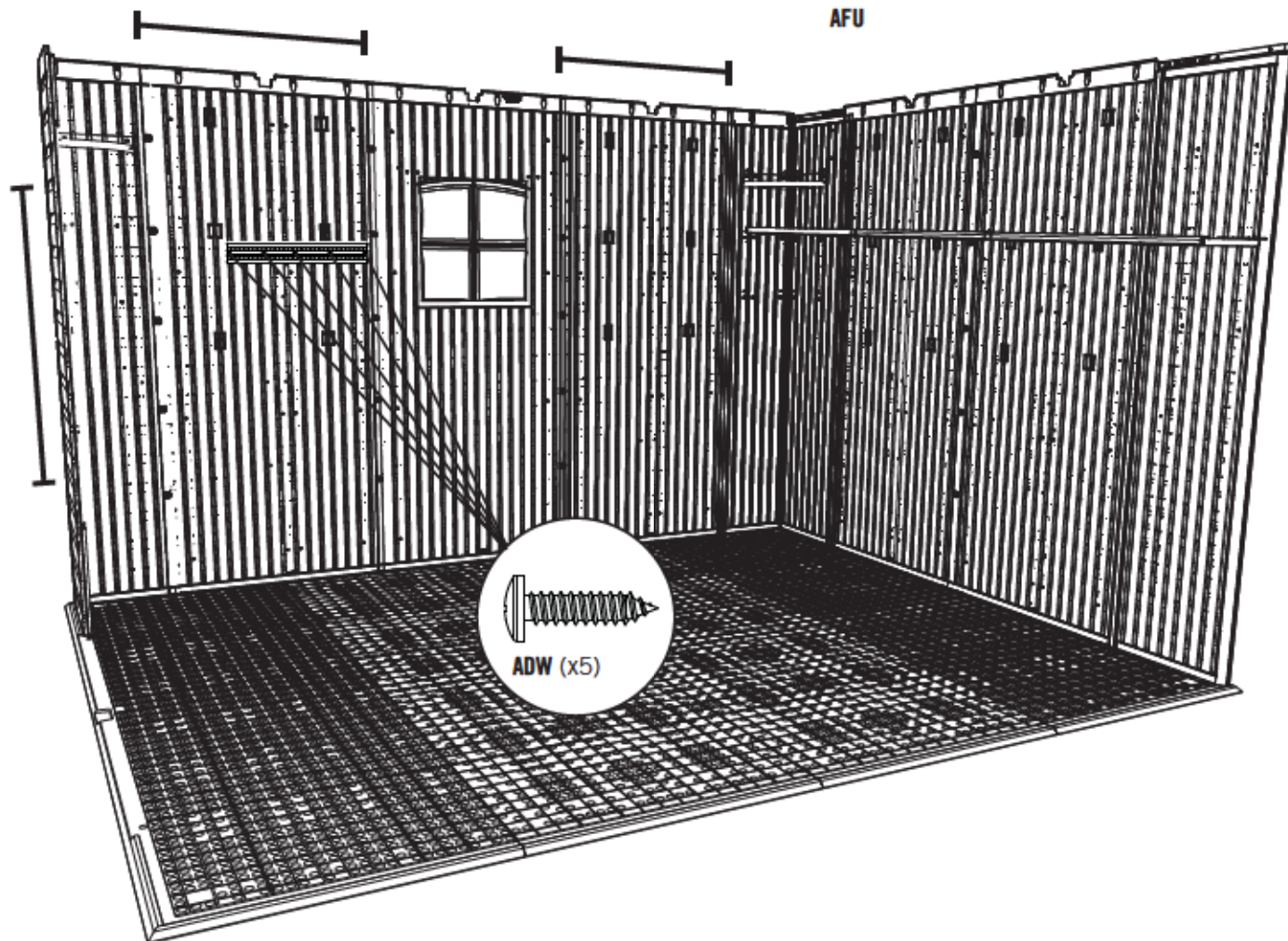

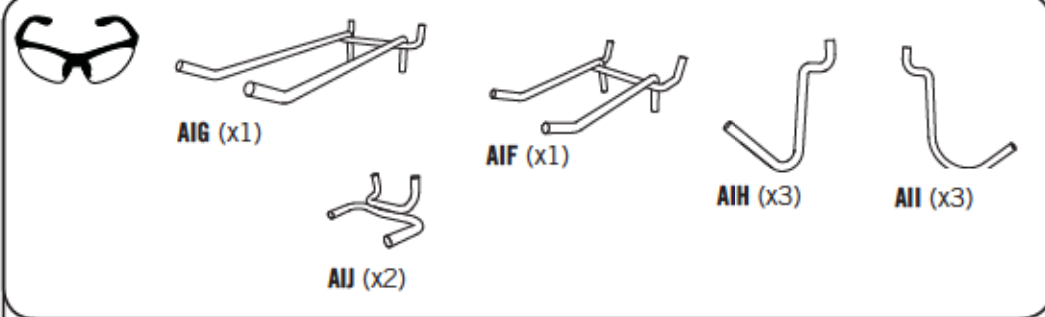

12.2

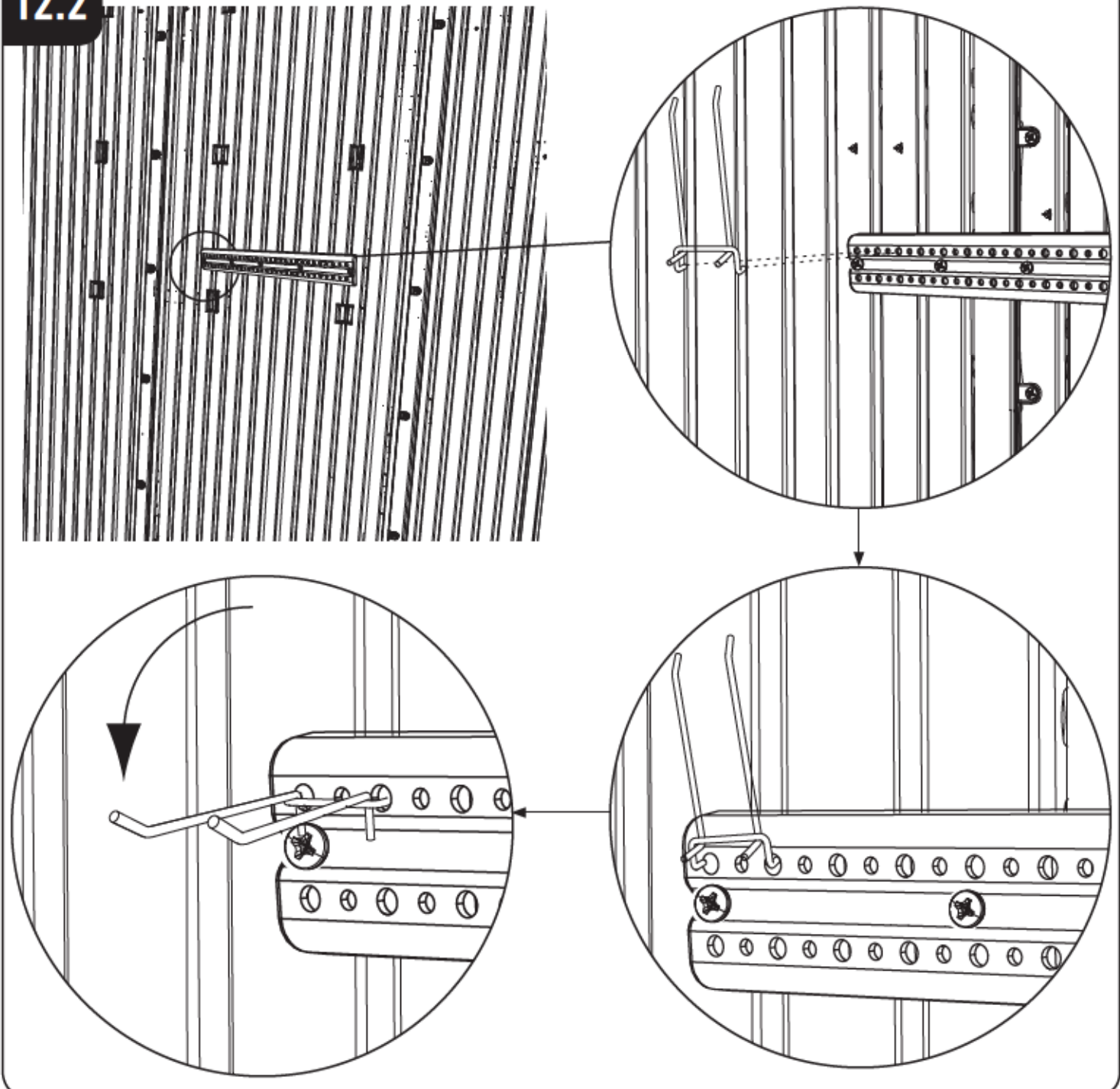



NO HARDWARE OR PARTS INCLUDED FOR THIS SECTION
 NINGÚN ELEMENTO O PIEZA INCLUIDO PARA ESTA SECCIÓN
 AUCUN ACCESSOIRE OU PIÈCE INCLUS POUR CETTE SECTION
 NÃO FORAM FORNECIDAS FERRAGENS PARA ESTA SECÇÃO
 KEINE WERKZEUGE ODER BEFESTIGUNGSELEMENTE ENTHALTEN FÜR DIESEN ABSCHNITT
 VOOR DEZE PAGINA ZIJN GEEN BEVESTIGINGSMATERIALEN NODIG
 このセクションにはハードウェアや部品は含まれません
 이 섹션에는 하드웨어 또는 부품이 포함되어 있지 않습니다



AIX (x4)

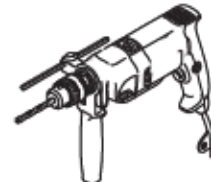



13



AIX (x4)



13.1

- If the Doors are not level, follow step 13.1.1 on this page or the next to even them out.
- Si las Puertas no son niveles, siga el pasos 13.1.1 en esta página o la siguiente para nivelarlas.
- Si les Portes ne sont niveaux l'une avec l'autre, suivez l'étape 13.1.1 sur cette page ou la suivante pour les niveler.

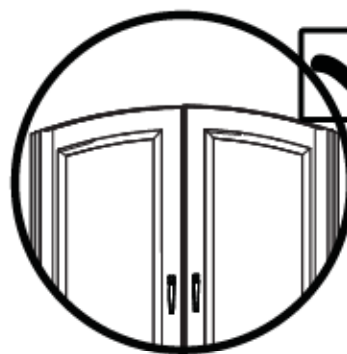

13.1.1

- If the Left Door is higher, follow this step.
- Si la Puerta izquierda es más alta, siga este paso.
- Si la Porte gache est plus haute, suivez cette étape.



+

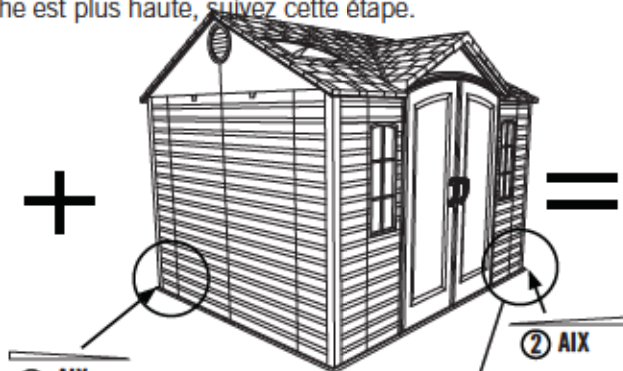

=

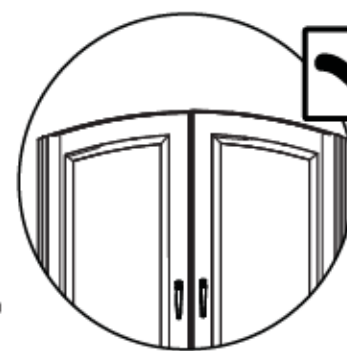

1

① AIX

2

② AIX

3

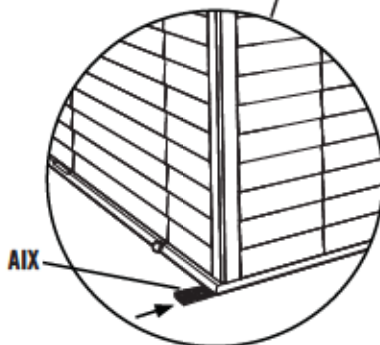

AIX



13



AIX (x4)



13.1.1

- If the Right Door is higher, follow this step.
- Si la Puerta derecha es más alta, siga este paso.
- Si la Porte droite est plus haute, suivez cette étape.

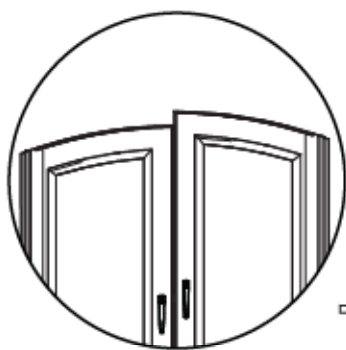

1

+



2

=

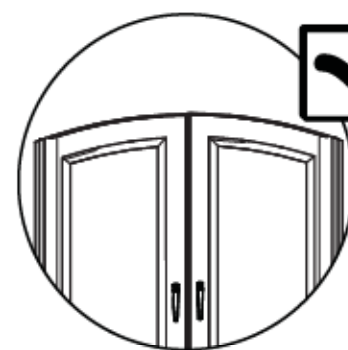

3

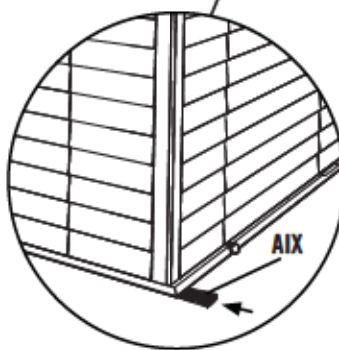



5/16" (7,9 mm)



13.2



• To anchor your shed, you must purchase the correct anchoring hardware. **For a concrete platform**, we recommend using a hammer drill, 5/16" (7,9 mm) masonry bit, four (4) 3/8" x 2" (9,5 mm x 5,1 cm) Concrete Screws and four (4) 3/8" x 1" (9,5 mm x 2,54 cm) Fender Washers. **Do not exceed a 3/8" diameter screw. Refer to your local hardware store for this hardware.**

• Para anclar el cobertizo, es necesario comprar los elementos de anclaje correctos. **Para una plataforma de concreto**, recomendamos que use un martillo perforador, broca de albañilería de 7,9 mm (5/16"), cuatro (4) Tornillos de anclaje para concreto de 9,5 mm x 5,1 cm (3/8" x 2") y cuatro (4) Rondanas de protección de 9,5 mm x 2,54 cm (3/8" x 1"). **No exceda un diámetro de 9,5 mm (3/8"). Refiérase a su ferretería local para obtener estos elementos.**

• Pour ancrer l'abri, il faut acheter les accessoires d'ancrage corrects. **Pour une plate-forme en béton**, nous recommandons que vous utilisiez une perceuse de percussion, un foret à maçonnerie de 7,9 mm (5/16"), quatre (4) Vis d'ancrage à béton de 9,5 mm x 5,1 cm (3/8" x 2") et quatre (4) Rondelles de protection de 9,5 mm x 2,54 cm (3/8" x 1"). **Ne dépassez pas un diamètre de 9,5 mm (3/8"). Votre quincaillerie du coin aura ces accessoires.**

• Para ancorar o seu alpendre deve comprar o material de ancoragem correcto. **Para uma plataforma de betão**, recomendamos a utilização de um martelo perfurador, 5/16" (7,9 mm) broca de alvenaria, quatro parafusos para betão (4) 3/8" x 2" (9,5 mm x 5,1 cm) e quatro anilhas (4) 3/8" x 1" (9,5 mm x 2,54 cm). **Não use parafusos com diâmetro superior a 3/8". Consulte a sua loja de ferragens local para obter este material.**

• Für das Verankern Ihres Schuppens müssen Sie die richtigen Verankerungswerkzeuge und Eisenwaren kaufen. **Für eine Betonplattform**, empfehlen wir: Bohrhammer, 7,9 mm (5/16 Zoll) Steinbohrereinsatz, vier (4) 9,5 mm x 5,1 cm (3/8 Zoll x 2 Zoll) Betonschrauben und vier (4) 9,5 mm x 2,54 cm (3/8 Zoll x 1 Zoll) Unterlegscheibe zum Sichern. **Der Schraubendurchmesser von 9,5 mm (3/8 Zoll) darf nicht überschritten werden! Erkundigen Sie sich in Ihrem örtlichen Heimwerkergeschäft nach diesen Eisenwaren.**

• Om uw schuur te verankeren, moet u de juiste verankeringsmiddelen kopen. **Bij een betonnen platform** raden wij het gebruik van een klopper, een 7,9 mm (5/16") steenboortje, vier (4) 9,5 mm x 5,1 cm (3/8" x 2") betonbouten en vier (4) 9,5 mm x 2,54 cm (3/8" x 1") onderlegingen aan. **Gebruik geen bouten c.q. schroeven met een diameter van meer dan 9,5 mm (3/8"). Raadpleeg uw plaatselijke metaalwarenwinkel voor deze bevestigingsmaterialen.**

• 小屋の固定には、正しい固定具を購入してください。コンクリートの台には、ハンマードリル、コンクリート用ドリルの歯(5/16インチ(7.9 mm))、コンクリート用ねじ(3/8インチ x 2インチ(9.5 mm x 5.1 cm)) 4本、フェンダーワッシャー(3/8インチ x 1インチ(9.5 mm x 2.54 cm)) 4枚の使用を推奨します。直径3/8インチ(9.5 mm)以上のねじを使用しないでください。この金具についてはお近くのホームセンターでお尋ねください。

• 간이창고를 바닥에 고정시키려면 적합한 고정용 하드웨어를 구입하셔야 합니다. 콘크리트 플랫폼에는, 해머 드릴, 5/16"(7.9mm) 석공용 비트, 네(4) 개의 3/8" x 2"(9.5mm x 5.1cm) 콘크리트 스크루 및 네(4) 개의 3/8" x 1"(9.5mm x 2.54cm) 펜더 와셔의 사용을 추천합니다. 직경 3/8" 가 넘는 스크루는 사용하지 마십시오. 이들 하드웨어에 관해 동네의 하드웨어 상점에 문의하십시오.

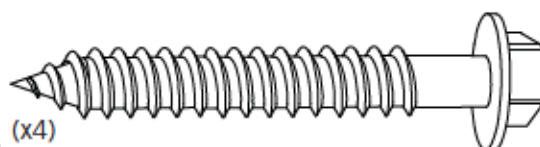
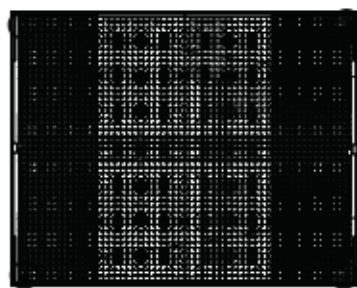

(x4)
(Not included) (No incluidos) (Pas inclus) (Não incluído)
(Nicht enthalten) (Niet bijgeleverd) (含まれません) (포함되어 있지 않음)

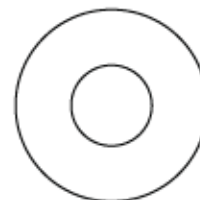

(x4)
(Not included) (No incluidos) (Pas inclus) (Não incluído)
(Nicht enthalten) (Niet bijgeleverd) (含まれません) (포함되어 있지 않음)



- Failure to anchor the shed may result in property damage and/or personal injury.
- El incumplimiento de anclar el cobertizo podría ocasionar daño a la propiedad y/o lesiones personales.
- Le non-respect d'ancrer votre abri peut résulter en dommage à propriété et/ou blessures graves personnelles.
- A não ancoragem do abrigo poderá resultar em ocorrência de danos na propriedade e/ou lesões pessoais.
- Unterlassen der Verankerung des Schuppens könnte Sachschaden und/oder Körperverletzung nach sich ziehen.
- Als u verzuimt de berging te verankeren, zijn schade aan eigendom en/of lichamelijk letsel mogelijk.
- シェッドにアンカーを付けない場合は、物的損害や身体傷害が生じる可能性があります。
- 이 간이창고를 바닥에 고정하지 않으면 자산의 손상 및/또는 신체 부상을 입을 수도 있습니다.

**13**

5/16" (7,9 mm)

**13.2**

• To anchor your shed, you must purchase the correct anchoring hardware. **For a wood-framed platform**, we recommend using a drill, 5/16" (7,9 mm) drill bit, four (4) 3/8" x 1 1/2" (9,5 mm x 3,81 cm) Lag Screws and four (4) 3/8" x 1" (9,5 mm x 2,54 cm) Fender Washers. **Do not exceed a 3/8" diameter screw. Refer to your local hardware store for this hardware.**

• Para anclar el cobertizo, es necesario comprar los elementos de anclaje correctos. **Para una plataforma hecho de madera**, recomendamos que use un taladro eléctrico, una broca de 7,9 mm (5/16"), cuatro (4) Tornillos para madera de 9,5 mm x 3,81 cm (3/8" x 1 1/2") y cuatro (4) Rondanas de protección de 9,5 mm x 2,54 cm (3/8" x 1"). **No exceda un diámetro de 9,5 mm (3/8"). Refiérase a su ferretería local para obtener estos elementos.**

• Pour ancrer l'abri, il faut acheter les accessoires d'ancrage corrects. **Pour une plate-forme en bois**, nous recommandons que vous utilisiez une perceuse électrique, un foret de 7,9 mm (5/16"), quatre (4) Vis de retard de 9,5mm x 3,81 cm (3/8" x 1 1/2"), et quatre (4) Rondelles de protection de 9,5mm x 2,54cm (3/8" x 1"). **Ne dépassez pas un diamètre de 9,5mm (3/8"). Votre quincaillerie du coin aura ces accessoires.**

• Para ancorar o seu alpendre deve comprar o material de ancoragem correcto. **Para uma plataforma de estrutura de madeira**, recomendamos a utilização de um berbequim, 5/16" (7,9 mm) broca, quatro parafusos para madeira 3/8" x 1 1/2" (9,5 mm x 3,81 cm) e quatro anilhas (4) 3/8" x 1" (9,5 mm x 2,54 cm). **Não use parafusos com diâmetro superior a 3/8". Consulte a sua loja de ferragens local para obter este material.**

• Für das Verankern Ihres Schuppens müssen Sie die richtigen Verankerungswerkzeuge und Eisenwaren kaufen. **Für eine Holzrahmenplattform** empfehlen wir: Bohrer, 7,9 mm (5/16 Zoll) Bohrereinsatz, vier (4) 9,5 mm x 3,81 cm (3/8 Zoll x 1 1/2 Zoll) Ankerschrauben und vier (4) 9,5 mm x 2,54 cm (3/8 Zoll x 1 Zoll) Unterlegscheiben zum Sichern. **Der Schraubendurchmesser von 9,5 mm (3/8 Zoll) darf nicht überschritten werden! Erkundigen Sie sich in Ihrem örtlichen Heimwerkergeschäft nach diesen Eisenwaren.**

• Om uw schuur te verankeren, moet u de juiste verankeringsmiddelen kopen. **Bij een platform bestaande uit een houten frame** raden wij het gebruik van een boor, een 7,9 mm (5/16") houtboortje, vier (4) 9,5 mm x 3,81 cm (3/8" x 1 1/2") houtschroeven en vier (4) 9,5 mm x 2,54 cm (3/8" x 1") onderleggingen aan. **Gebruik geen bouten c.q. schroeven met een diameter van meer dan 9,5 mm (3/8"). Raadpleeg uw plaatselijke metaalwarenwinkel voor deze bevestigingsmaterialen.**

• 小屋の固定には、正しい固定具を購入してください。木材で枠取りした台には、ドリル、ドリルの歯(5/16インチ(7.9mm))、ラグねじ(3/8インチ x 1 1/2インチ(9.5 mm x 3.81 cm)) 4本、フェンダーワッシャー(3/8インチ x 1インチ(9.5 mm x 2.54 cm)) 4枚の使用を推奨します。直径3/8インチ(9.5 mm)以上のねじを使用しないでください。この金具についてはお近くのホームセンターでお尋ねください。

• 간이창고를 바닥에 고정시키려면 적합한 고정용 하드웨어를 구입하셔야 합니다. 목재 프레임 플랫폼에는, 드릴, 5/16"(7.9mm) 드릴 비트, 네(4)개의 3/8" x 1 1/2"(9.5mm x 3.81cm) 래그 스크루 및 네(4)개의 3/8" x 1"(9.5mm x 2.54cm) 펜더 와셔의 사용을 추천합니다. 직경 3/8" 가 넘는 스크루는 사용하지 마십시오. 이들 하드웨어에 관해 동네의 하드웨어 상점에 문의하십시오.

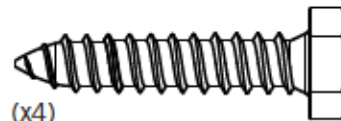
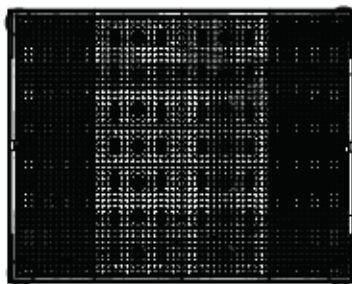

(x4)

(Not included) (No incluidos) (Pas inclus) (Não incluído)
(Nicht enthalten) (Niet bijgeleverd) (含まれません) (포함되어 있지 않음)

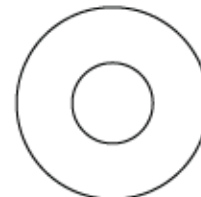

(x4)

(Not included) (No incluidos) (Pas inclus) (Não incluído)
(Nicht enthalten) (Niet bijgeleverd) (含まれません) (포함되어 있지 않음)



- Failure to anchor the shed may result in property damage and/or personal injury.
- El incumplimiento de anclar el cobertizo podría ocasionar daño a la propiedad y/o lesiones personales.
- Le non-respect d'ancrer votre abri peut résulter en dommage à propriété et/ou blessures graves personnelles.
- A não ancoragem do abrigo poderá resultar em ocorrência de danos na propriedade e/ou lesões pessoais.
- Unterlassen der Verankerung des Schuppens könnte Sachschaden und/oder Körperverletzung nach sich ziehen.
- Als u verzuimt de berging te verankeren, zijn schade aan eigendom en/of lichamelijk letsel mogelijk.
- シェッドにアンカーを付けない場合は、物的損害や身体傷害が生じる可能性があります。
- 이 간이창고를 바닥에 고정하지 않으면 자산의 손상 및/또는 신체 부상을 입을 수도 있습니다.

**13**

5/16" (7,9 mm)

**13.2**

• To anchor your shed, you must purchase the correct anchoring hardware. **For a wood-framed platform filled with road base, we recommend using an electric drill, 5/16" (7,9 mm) drill bit, four (4) 3/8" x 1 1/2" (9,5 mm x 3,81 cm) Lag Screws and four (4) 3/8" x 1" (9,5 mm x 2,54 cm) Fender Washers. Do not exceed a 3/8" diameter screw. Refer to your local hardware store for this hardware.**

• Para anclar el cobertizo, es necesario comprar los elementos de anclaje correctos. **Para una plataforma hecho de madera y lleno de base granular, recomendamos que use un taladro eléctrico, una broca de 7,9 mm (5/16"), cuatro (4) Tornillos para madera de 9,5 mm x 3,81 cm (3/8" x 1 1/2") y cuatro (4) Rondanas de protección de 9,5 mm x 2,54 cm (3/8" x 1"). No exceda un diámetro de 9,5 mm (3/8"). Refiérase a su ferretería local para obtener estos elementos.**

• Pour ancrer l'abri, il faut acheter les accessoires d'ancrage corrects. **Pour une plate-forme en bois remplie avec enrobé de base, nous recommandons que vous utilisiez une perceuse électrique, un foret de 7,9 mm (5/16"), quatre (4) Vis de retard de 9,5mm x 3,81 cm (3/8" x 1 1/2"), et quatre (4) Rondelles de protection de 9,5mm x 2,54cm (3/8" x 1"). Ne dépassez pas un diamètre de 9,5mm (3/8"). Votre quincaillerie du coin aura ces accessoires.**

• Para ancorar o seu alpendre deve comprar o material de ancoragem correcto. **Para uma plataforma de estrutura de madeira cheia com base de pavimento, recomendamos a utilização de um berbequim eléctrico, 5/16" (7,9 mm) broca, quatro parafusos para madeira 3/8" x 1 1/2" (9,5 mm x 3,81 cm) e quatro anilhas (4) 3/8" x 1" (9,5 mm x 2,54 cm). Não use parafusos com diâmetro superior a 3/8". Consulte a sua loja de ferragens local para obter este material.**

• Für das Verankern Ihres Schuppens müssen Sie die richtigen Verankerungswerkzeuge und Eisenwaren kaufen. **Für eine mit Straßenbelag gefüllte Holzrahmenplattform:** Bohrer, 7,9 mm (5/16 Zoll) Bohreinsatz, vier (4) 9,5 mm x 3,81 cm (3/8 Zoll x 1 1/2 Zoll) Ankerschrauben und vier (4) 9,5 mm x 2,54 cm (3/8 Zoll x 1 Zoll) Unterlegscheiben zum Sichern. **Der Schraubendurchmesser von 9,5 mm (3/8 Zoll) darf nicht überschritten werden! Erkundigen Sie sich in Ihrem örtlichen Heimwerkergeschäft nach diesen Eisenwaren.**

• Om uw schuur te verankeren, moet u de juiste verankeringsmiddelen kopen. **Bij een platform bestaande uit een houten frame gevuld met grof-aggregaatmengsel raden wij het gebruik van een elektrische boor, een 7,9 mm (5/16") houtboortje, vier (4) 9,5 mm x 3,81 cm (3/8" x 1 1/2") houtschroeven en vier (4) 9,5 mm x 2,54 cm (3/8" x 1") onderlegingen aan. Gebruik geen bouten c.q. schroeven met een diameter van meer dan 9,5 mm (3/8"). Raadpleeg uw plaatselijke metaalwarenwinkel voor deze bevestigingsmaterialen.**

• 小屋の固定には、正しい固定具を購入してください。木枠付き道路基盤の台には、ドリル、ドリルの歯(5/16インチ(7.9mm))、ラグねじ(3/8インチx1 1/2インチ(9.5mm x 3.81cm))4本、フェンダーワッシャー(3/8インチx1インチ(9.5mm x 2.54cm))4枚の使用を推奨します。直径3/8インチ(9.5mm)以上のねじを使用しないでください。この金具についてはお近くのホームセンターでお尋ねください。

• 간이창고를 바닥에 고정시키려면 적합한 고정용 하드웨어를 구입하셔야 합니다. 도로 기반을 채운 목재 프레임 플랫폼에는, 전기드릴, 5/16"(7.9mm) 드릴 비트, 네(4) 개의 3/8" x 1 1/2"(9.5mm x 3.81cm) 레그 스크루 및 네(4) 개의 3/8" x 1"(9.5mm x 2.54cm) 펜더 와셔의 사용을 추천합니다. 직경 3/8" 가 넘는 스크루는 사용하지 마십시오. 이들 하드웨어에 대해 동네의 하드웨어 상점에 문의하십시오.

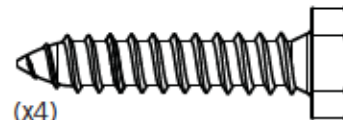
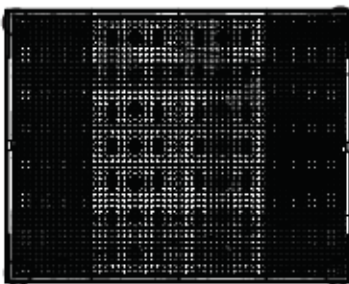

(Not included) (No incluidos) (Pas inclus) (Não incluído)
(Nicht enthalten) (Niet bijgeleverd) (含まれません) (포함되어 있지 않음)

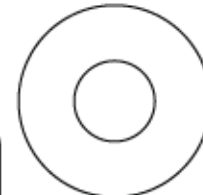

(Not included) (No incluidos) (Pas inclus) (Não incluído)
(Nicht enthalten) (Niet bijgeleverd) (含まれません) (포함되어 있지 않음)



- Failure to anchor the shed may result in property damage and/or personal injury.
- El incumplimiento de anclar el cobertizo podría ocasionar daño a la propiedad y/o lesiones personales.
- Le non-respect d'ancrer votre abri peut résulter en dommage à propriété et/ou blessures graves personnelles.
- A não ancoragem do abrigo poderá resultar em ocorrência de danos na propriedade e/ou lesões pessoais.
- Unterlassen der Verankerung des Schuppens könnte Sachschaden und/oder Körperverletzung nach sich ziehen.
- Als u verzuimt de berging te verankeren, zijn schade aan eigendom en/of lichamelijk letsel mogelijk.
- シェッドにアンカーを付けられない場合は、物的損害や身体傷害が生じる可能性があります。
- 이 간이창고를 바닥에 고정하지 않으면 자산의 손상 및/또는 신체 부상을 입을 수도 있습니다.

CLEANING & CARE

Congratulations on your Lifetime® product purchase. By following the instructions below, your new Lifetime product should provide you with years of service and enjoyment.
The polyethylene panels are stain- and solvent-resistant. Most stains can be removed using a mild soap and a soft-bristled brush. Abrasive cleaning materials may scratch the plastic and are not recommended. Repair scratches or rust spots on the metal by sanding the affected area lightly; using a rust preventative spray primer; and finally, spraying with a high-gloss spray enamel paint. Avoid placing a direct heat source on or near surfaces unless using a heat barrier.

LIMPIEZA Y CUIDADO

Felicidades por la compra de su producto Lifetime®. Si cumple todas las instrucciones siguientes, podrá disfrutar satisfactoriamente del servicio de su nuevo producto Lifetime.
Las paredes y los estantes de polietileno son resistentes a las manchas y al solvente. Use para su limpieza un jabón suave y un cepillo de cerdas blandas. Los materiales limpiadores abrasivos podrían raspar el plástico y no son recomendados. Repare las raspaduras o zonas oxidadas de las piezas de metal lijando ligeramente el área afectada; aplique luego una impresión en aerosol para prevenir la formación de óxido; finalmente pinte con un esmalte brillante en aerosol. Evite colocar una fuente directa de calor sobre las superficies o cerca de ellas a menos que use una barrera contra el calor.

NETTOYAGE ET ENTRETIEN

Nous vous félicitons d'avoir acheté ce produit Lifetime®. En suivant les instructions ci-dessous, votre nouvel produit Lifetime devrait vous fournir des années de service et de plaisir.
Les murs et les étagères en polyéthylène sont résistants aux tâches et solvants de nettoyage. Pour les nettoyer, servez-vous d'un savon doux et d'une brosse douce. Les produits abrasifs de nettoyage risquent d'égratigner le plastique et ne sont pas recommandés. Pour réparer les égratignures ou tâches de rouille sur le métal, frottez légèrement l'endroit affecté ou papier de verre, puis passez un couche de produit vaporisant préventif et enfin vaporisez une peinture émail brillant élevé. Évitez de placer une source de chaleur directe sur ou près des surfaces, ou protégez-les à l'aide d'une protection contre la chaleur.

LIMPEZA E CUIDADOS A TER

Parabéns por ter adquirido o seu produto Lifetime®. Ao seguir as instruções abaixo, o seu novo produto Lifetime oferecerá-lhe-á anos de serviço e usufruto.
Os painéis de polietileno são resistentes às manchas e solventes. A maioria das manchas pode ser removida através da aplicação de um produto de limpeza não abrasivo com uma escova de cerda suave. Os materiais de limpeza abrasivos podem riscar o plástico, pelo que não são recomendados. Repare os riscos ou manchas de ferrugem no metal lixando ligeiramente a área afetada; utilize um primário em spray para a prevenção da ferrugem e, finalmente, aplique uma tinta de esmalte em spray de brilho elevado. Evite aplicar qualquer fonte de calor direta sobre ou na proximidade das superfícies, exceto se utilizar uma barreira de calor.

REINIGUNG UND PFLEGE

Wir gratulieren Ihnen zum Erwerb Ihres Lifetime® Produkt. Wenn Sie die nachstehenden Anleitungen befolgen, wird Ihnen Ihr Lifetime-Produkt viele Jahre dienen und Ihnen Freude bereiten.
Die Polyethylenwände und Regale sind schmutzabweisend und lösungsmittelbeständig. Die meisten Flecken können mit einem milden Reinigungsmittel und einer weichborstigen Bürste entfernt werden. Scheuermittel und Topfschwämme werden nicht empfohlen, da sie die Plastikteile zerkratzen können. Kratzer oder Rostflecken am Metall können entfernt werden, indem man den betroffenen Bereich leicht abschleift, ein Rostschutzgrundierungsmittel aufträgt und die Fläche zum Schluss mit einem Hochglanzlack besprüht. Stellen Sie keine direkte Hitzequelle auf oder neben die Oberflächen, wenn Sie keine Wärmesperre benutzen.

REINIGING & VERZORGING

Hartelijk gefeliciteerd met uw aankoop van een Lifetime® product. Als u de volgende aanwijzingen opvolgt, zal uw nieuwe Lifetime product jarenlang mee kunnen.
De wanden en planken van polyetheleen zijn bestendig tegen vlekken en oplosmiddelen. De meeste vlekken kunnen worden verwijderd met een milde soort zeep en een zachte borstel. Schurende reinigingsmaterialen kunnen het plastic krassen en worden niet aanbevolen. U kunt krassen of roestvlekken op het metaal repareren door het betreffende deel licht te schuren, een roestwerende spuitgrondverf aan te brengen en tenslotte een laagje hoogglansspuitlak aan te brengen. Plaats geen directe hittebronnen op of in de omgeving van oppervlakken, tenzij er een hittebarrière wordt gebruikt.

掃除とお手入れ

Lifetime® アウトドア・シェッドをご購入いただきありがとうございます。以下の指示に従うことで、お客様の新しいLifetimeシェッド製品を長年にわたってご使用および活用いただけます。

ポリエチレン製の壁と棚は、耐汚染性および耐溶性となっております。ほとんどの汚れは、中性洗剤および毛先のやわらかいブラシを使用して取り除くことができます。研磨用の洗剤やブラシの使用は、プラスチックに傷をつける可能性があるため推奨しません。金属の傷や錆の部分は、該当部分に軽くサンドペーパーをかけることで修繕できます。そのとき、さび防止用スプレープライマーを使用してください。最後に、高光沢のスプレー式エナメルペイントを使用して仕上げます。熱障壁を使用していない限り、表面または表面近くに直接の熱源を置かないようにしてください。

청소 및 손질

Lifetime 제품의 구입을 축하 드립니다. 다음의 지침을 참조하시면 귀하의 새로운 Lifetime 제품은 앞으로 여러 해 동안 서비스와 즐거움을 귀하께 선사할 것입니다.

폴리에틸렌 패널은 때와 솔벤트에 내성을 갖고 있습니다. 약한 비누와 부드러운 솔을 사용하면 대부분의 때가 제거할 수 있습니다. 연마용 세척제는 플라스틱에 상처를 낼 수 있으므로 추천되지 않습니다. 스크래치 또는 금속의 녹슨 곳은 가볍게 샌드페이퍼로 긁어 내십시오; 녹 방지용 스프레이 프라이머를 사용하고; 마지막으로 고광택 에나멜 페인트를 분사하십시오. 열 차단막을 설치하지 않는 한 열이 있는 곳이나 근처에는 설치하지 마십시오.

清潔與維護

祝賀您購買了Lifetime® 產品。請按照下述步驟護理您的全新Lifetime® 產品，使它們持久耐用，並給您帶來無盡的快樂。

嵌板具有防汙和耐溶劑性。大多數的污漬可用溫和的潔手液和軟刷清潔乾淨。磨蝕性的清潔品可能刮壞塑膠表面，因此不建議使用。金屬表面的刮痕或鏽跡可通過輕輕研磨、噴上防銹底漆、最後噴上高光澤瓷漆便可修復。除非使用了隔熱材料/產品，否則不要在本產品表面上或表面附近置放直接熱源。

10-YEAR LIMITED FACTORY WARRANTY

THE MANUFACTURER RESERVES THE RIGHT TO MAKE SUBSTITUTIONS TO WARRANTY CLAIMS IF PARTS ARE UNAVAILABLE OR OBSOLETE.

1. Lifetime outdoor sheds are warranted to the original purchaser to be free from defects in material or workmanship for a period of ten years from the date of original retail purchase. The word "defects" is defined as imperfections that impair the use of the product. Defects resulting from misuse, abuse or negligence will void this warranty. This warranty does not cover defects due to improper installation, alteration or accident. This warranty does not cover damage caused by vandalism, rusting, "acts of nature" or any other event beyond the control of the manufacturer.
2. This warranty is nontransferable and is expressly limited to the repair or replacement of defective product. If the product is defective within the terms of this warranty, Lifetime Products, Inc. will repair or replace defective parts at no cost to the purchaser. Shipping charges to and from the factory or distribution center are not covered and are the responsibility of the purchaser. Labor charges and related expenses for removal, installation or replacement of the shed or its components are not covered under this warranty.
3. This warranty does not cover scratching or scuffing of the product that may result from normal usage. In addition, defects resulting from intentional damage, negligence, unreasonable use or hanging from the truss will void this warranty.
4. Liability for incidental or consequential damages is excluded to the extent permitted by law. While every attempt is made to embody the highest degree of safety in all equipment, freedom from injury cannot be guaranteed. The user assumes all risk of injury resulting from the use of this product. All merchandise is sold on this condition, and no representative of the company may waive or change this policy.
5. This product is not intended for institutional or commercial use; Lifetime Products, Inc. does not assume any liability for such use. Institutional or commercial use will void the warranty.
6. This warranty is expressly in lieu of all other warranties, expressed or implied, including warranties of merchantability or fitness for use to extent permitted by Federal and state law. Neither Lifetime Products, Inc., nor any representative assumes any other liability in connection with this product. This warranty gives you specific legal rights, and you may also have other rights which vary from state to state.

PLEASE INCLUDE YOUR DATED SALES RECEIPT AND PHOTOGRAPHS OF DAMAGED PARTS.

REPORT PRODUCT DEFECTS IN WRITING TO:
Lifetime Products, Inc., PO Box 160010 Clearfield, UT 84016-0010
or call 1-800-225-3865 M-F 7 a.m. to 5 p.m. MST.

REGISTER YOUR PRODUCT FOR QUICKER CUSTOMER SERVICE.

Visit www.lifetime.com or call 1-800-225-3865 to register your product today.

FOR INTERNATIONAL WARRANTY CLAIMS:

All warranty claims must be accompanied by a sales receipt. Report all warranty claims in writing to your regional sales support representative. Please include your dated sales receipt and photographs of damaged parts. To identify the representative for your region—Please visit: www.lifetime.com/international



www.lifetime.com

GARANTÍA DE FÁBRICA LIMITADA POR 10 AÑOS

EL FABRICANTE SE RESERVA EL DERECHO DE HACER SUSTITUCIONES EN LOS ELEMENTOS REEMPLAZADOS BAJO GARANTÍA SI LAS PIEZAS NO ESTÁN DISPONIBLES O SON OBSOLETAS.

1. El comprador original recibe la garantía de que los cobertizos Lifetime estarán libres de defectos de material o de mano de obra por un período de 10 años a contar desde la fecha de la compra original. La palabra "defectos" se define como imperfecciones que perjudican el uso del producto. Los defectos emergentes de un mal uso, abuso o negligencia invalidarán esta garantía. Esta garantía no cubre defectos debidos a una instalación o alteración incorrecta o a un accidente. Esta garantía no cubre daños causados por vandalismo, oxidación, "actos de la naturaleza" u otros eventos que estén más allá del control del fabricante.
2. Esta garantía es intransferible, y queda expresamente limitada a la reparación o reemplazo de los productos defectuosos. Si el producto se encuentra defectuoso dentro de los términos de esta garantía, Lifetime Products, Inc. reparará o reemplazará las piezas defectuosas sin costo alguno para el comprador. Los gastos de envío hacia y desde la fábrica no están cubiertos, y quedan bajo la responsabilidad del comprador.
3. Esta garantía no cubre raspaduras ni marcas en el producto que pueden resultar de su uso normal. Además, los defectos causados por daños intencionales, negligencia, uso irrazonable o por colgarse de las cabriadas invalidarán esta garantía.
4. La responsabilidad por daños incidentales o consecuentes queda excluida hasta el punto en que lo permita la ley. Si bien se hace el mayor esfuerzo posible para lograr el más alto grado de seguridad en todos nuestros equipos, no puede garantizarse la libertad de cualquier tipo de lesión. El usuario asume todos los riesgos de lesiones emergentes del uso de este producto. Toda nuestra mercadería se vende bajo esta condición, y ningún representante de la compañía puede anular ni cambiar esta política.
5. Este producto no está pensado para el uso institucional ni comercial; Lifetime Products, Inc. no asume ninguna otra responsabilidad en conexión con este producto. El uso institucional o comercial invalidará la garantía.
6. Esta garantía se otorga en reemplazo expreso de toda otra garantía, expresa o implícita, incluidas las garantías de comercialización o adaptación para el uso en la medida permitida por las leyes federales y estatales. Ni Lifetime Products, Inc., ni ninguno de sus representantes asume ninguna otra responsabilidad en conexión con este producto. Esta garantía le otorga derechos legales específicos, y usted puede tener otros derechos que varían de estado a estado.

NINGUNA GARANTÍA OFRECIDA POR EL FABRICANTE ES VÁLIDA EN MÉXICO

TODOS LOS RECLAMOS DE GARANTÍA DEBEN ESTAR ACOMPAÑADOS POR UN RECIBO DE COMPRA

INFORME POR ESCRITO LOS DEFECTOS EN EL PRODUCTO A:

Por favor, incluya el recibo de compra fechado y fotografías de las piezas dañadas.

Lifetime Products, Inc., PO Box 160010 Clearfield, UT 84016-0010,

o llame al 1.800.225.3865 de lunes a viernes de 0700 hasta 1700 (Hora de las Montañas)

REGISTRE SU PRODUCTO

Visite nuestra página en Internet www.lifetime.com, o llame al 1.800.225.3865 para registrar su producto hoy.

PARA RECLAMOS DE GARANTÍA INTERNACIONALES:

Todos los reclamos de garantía deben estar acompañados por un recibo de compra. Informe por escrito todos los reclamos de garantía a su representante regional de ventas. Favor de incluir su recibo de compra fechado y fotografías de las piezas dañadas.

Para identificar el representante de su región—visite www.lifetime.com/international



www.lifetime.com

GARANTIE DE FABRICATION LIMITÉE DE 10 ANS

LE FABRICANT RÉSERVE LE DROIT DE FAIRE DES SUBSTITUTIONS EN CAS DE RECOURS EN GARANTIE SI LES PIÈCES NE SONT PAS DISPONIBLES OR SONT OBSOLÈTES

1. Les abris extérieurs Lifetime sont garantis à l'acheteur d'origine contre tous défauts de matériau ou de fabrication pendant une durée de dix ans à partir de la date d'achat d'origine. Le mot « défauts » signifie des défauts qui empêchent l'utilisation du produit. Les défauts résultant de mauvais usage, d'abus ou de négligence annulent cette garantie. Cette garantie ne couvre pas les dommages causés par le vandalisme, la rouille, « les calamités naturelles » ou tout autre événement en dehors du contrôle du fabricant.
2. Cette garantie n'est pas transférable et est expressément limitée à la réparation ou au remplacement du produit défectueux. Si le produit est déclaré défectueux selon les termes de cette garantie, Lifetime Products, Inc. réparera ou remplacera les parties défectueuses gratuitement pour l'acheteur. Les frais d'expéditions aller et retour de l'usine ne sont pas couverts et sont à la charge de l'acheteur. Les frais de main-d'œuvre et frais associés à l'enlèvement, au montage ou au remplacement de l'abri ou de ses composantes ne sont pas couverts par cette garantie.
3. Cette garantie ne couvre pas les égratignures ou éraillures du produits résultant d'une utilisation normale. Par ailleurs, les défauts résultant de dommages intentionnels, négligence, utilisation abusive ou suspension à partir de l'entretoise annulent cette garantie.
4. Toute responsabilité pour dommages incidents ou conséquents est exclue dans la mesure permise par la loi. Bien que toutes les mesures aient été prises pour intégrer le plus haut degré de sécurité dans l'ensemble du matériel, l'impossibilité de blessure ne peut pas être garantie. L'utilisateur assume tous les risques de blessure résultant de l'utilisation de ce produit. L'ensemble de la marchandise est vendu en vertu de cette condition et aucune personne représentant la société ne peut déroger à cette politique, ni la modifier.
5. Ce produit n'est pas prévu pour l'usage institutionnel ni commercial; Lifetime Products, Inc. n'assume aucune responsabilité pour tel usage. L'utilisation institutionnelle ou commerciale annulera cette garantie.
6. Cette garantie remplace expressément toutes autres garanties, expresses ou tacites, y compris les garanties de commercialisation ou d'adaptation à un but particulier dans la mesure permise par les lois fédérales et des états. Ni Lifetime Products, Inc. ni aucun de ses représentants n'assume aucune autre responsabilité concernant ce produit. Cette garantie vous accorde des droits particuliers, et vous aurai peut-être des autres droits qui varient d'un état à l'autre.

TOUS LES RECOURS EN GARANTIE DOIVENT ÊTRE ACCOMPAGNÉS DU REÇU DE VENTE.

FAIRE PARVENIR UN RAPPORT PAR ÉCRIT DE DÉFECTUOSITÉ DU PRODUIT A :

Lifetime Products, Inc., PO Box 160010 Clearfield, UT 84016-0010

ou appelez-nous au 1.800.225.3865 lundi à vendredi 0700 - 1700 (HNR)

ENREGISTREZ VOTRE ARTICLE À :

www.lifetime.com, ou appelez-nous au 1.800.225.3865 pour enregistrer votre article aujourd'hui.

POUR RECOURS EN GARANTIE INTERNATIONAUX:

Tous les recours en garantie doivent être accompagnés du reçu de vente. Faire parvenir un rapport par écrit de défectuosité du produit à votre représentant régional de ventes. Veuillez inclure votre reçu de vente daté et photographies des pièces endommagées. Pour identifier votre représentant régional—visitez www.lifetime.com/international



www.lifetime.com

ENHANCE YOUR LIFETIME® PURCHASE BY ADDING ACCESSORIES OR OTHER GREAT PRODUCTS

To purchase accessories or other Lifetime® products, visit us at:

www.lifetime.com

Or call: 1-800-424-3865

MEJORE SU COMPRA LIFETIME® Y AÑADA ACCESORIOS U OTROS PRODUCTOS EXCELENTES

Para comprar accesorios u otros productos Lifetime® EUA, visítenos en:

www.lifetime.com

O llame al: 1.800.424.3865

AMÉLIOREZ VOTRE ACHAT LIFETIME® EN AJOUTANT DES ACCESSOIRES OU AUTRES PRODUITS

Pour acheter des accessoires ou autres produits Lifetime®, rendez-vous une visite à :

www.lifetime.com

Ou appelez-nous au 1.800.424.3865

